

atrin **electronic**

Expertise, variety and quality



www.atrinelec.com

آترین الکترونیک

تخصص، تنوع و کیفیت

02166766957 - 02166766927



info@atrinelec.com



تهران پاساژ امجد طبقه 1 واحد 16



@atrinelec





PIC16F684

Data Sheet

14-Pin Flash-Based, 8-Bit
CMOS Microcontrollers with
nanoWatt Technology

Note the following details of the code protection feature on Microchip devices:

- Microchip products meet the specification contained in their particular Microchip Data Sheet.
- Microchip believes that its family of products is one of the most secure families of its kind on the market today, when used in the intended manner and under normal conditions.
- There are dishonest and possibly illegal methods used to breach the code protection feature. All of these methods, to our knowledge, require using the Microchip products in a manner outside the operating specifications contained in Microchip's Data Sheets. Most likely, the person doing so is engaged in theft of intellectual property.
- Microchip is willing to work with the customer who is concerned about the integrity of their code.
- Neither Microchip nor any other semiconductor manufacturer can guarantee the security of their code. Code protection does not mean that we are guaranteeing the product as "unbreakable."

Code protection is constantly evolving. We at Microchip are committed to continuously improving the code protection features of our products. Attempts to break Microchip's code protection feature may be a violation of the Digital Millennium Copyright Act. If such acts allow unauthorized access to your software or other copyrighted work, you may have a right to sue for relief under that Act.

Information contained in this publication regarding device applications and the like is intended through suggestion only and may be superseded by updates. It is your responsibility to ensure that your application meets with your specifications. No representation or warranty is given and no liability is assumed by Microchip Technology Incorporated with respect to the accuracy or use of such information, or infringement of patents or other intellectual property rights arising from such use or otherwise. Use of Microchip's products as critical components in life support systems is not authorized except with express written approval by Microchip. No licenses are conveyed, implicitly or otherwise, under any intellectual property rights.

Trademarks

The Microchip name and logo, the Microchip logo, Accuron, dsPIC, KEELOQ, microID, MPLAB, PIC, PICmicro, PICSTART, PRO MATE, PowerSmart, rfPIC, and SmartShunt are registered trademarks of Microchip Technology Incorporated in the U.S.A. and other countries.

AmpLab, FilterLab, MXDEV, MXLAB, PICMASTER, SEEVAL, SmartSensor and The Embedded Control Solutions Company are registered trademarks of Microchip Technology Incorporated in the U.S.A.

Analog-for-the-Digital Age, Application Maestro, dsPICDEM, dsPICDEM.net, dsPICworks, ECAN, ECONOMONITOR, FanSense, FlexROM, fuzzyLAB, In-Circuit Serial Programming, ICSP, ICEPIC, Migratable Memory, MPASM, MPLIB, MPLINK, MPSIM, PICKit, PICDEM, PICDEM.net, PICLAB, PICtail, PowerCal, PowerInfo, PowerMate, PowerTool, rLAB, rfPICDEM, Select Mode, Smart Serial, SmartTel and Total Endurance are trademarks of Microchip Technology Incorporated in the U.S.A. and other countries.

SQTP is a service mark of Microchip Technology Incorporated in the U.S.A.

All other trademarks mentioned herein are property of their respective companies.

© 2004, Microchip Technology Incorporated, Printed in the U.S.A., All Rights Reserved.

 Printed on recycled paper.

QUALITY MANAGEMENT SYSTEM
CERTIFIED BY DNV
== ISO/TS 16949:2002 ==

Microchip received ISO/TS-16949:2002 quality system certification for its worldwide headquarters, design and wafer fabrication facilities in Chandler and Tempe, Arizona and Mountain View, California in October 2003. The Company's quality system processes and procedures are for its PICmicro® 8-bit MCUs, KEELOQ® code hopping devices, Serial EEPROMs, microperipherals, nonvolatile memory and analog products. In addition, Microchip's quality system for the design and manufacture of development systems is ISO 9001:2000 certified.

14-Pin Flash-Based, 8-Bit CMOS Microcontrollers with nanoWatt Technology

High-Performance RISC CPU:

- Only 35 instructions to learn:
 - All single-cycle instructions except branches
- Operating speed:
 - DC – 20 MHz oscillator/clock input
 - DC – 200 ns instruction cycle
- Interrupt capability
- 8-level deep hardware stack
- Direct, Indirect and Relative Addressing modes

Special Microcontroller Features:

- Precision Internal Oscillator:
 - Factory calibrated to $\pm 1\%$
 - Software selectable frequency range of 8 MHz to 31 kHz
 - Software tunable
 - Two-speed Start-up mode
 - Crystal fail detect for critical applications
 - Clock mode switching during operation for power savings
- Power-saving Sleep mode
- Wide operating voltage range (2.0V-5.5V)
- Industrial and Extended Temperature range
- Power-on Reset (POR)
- Power-up Timer (PWRT) and Oscillator Start-up Timer (OST)
- Brown-out Detect (BOD) with software control option
- Enhanced low-current Watchdog Timer (WDT) with on-chip oscillator (software selectable nominal 268 seconds with full prescaler) with software enable
- Multiplexed Master Clear with pull-up/input pin
- Programmable code protection
- High Endurance Flash/EEPROM cell:
 - 100,000 write Flash endurance
 - 1,000,000 write EEPROM endurance
 - Flash/Data EEPROM retention: > 40 years

Low-Power Features:

- Standby Current:
 - 1 nA @ 2.0V, typical
- Operating Current:
 - 8.5 μA @ 32 kHz, 2.0V, typical
 - 100 μA @ 1 MHz, 2.0V, typical
- Watchdog Timer Current:
 - 1 μA @ 2.0V, typical

Peripheral Features:

- 12 I/O pins with individual direction control:
 - High current source/sink for direct LED drive
 - Interrupt-on-pin change
 - Individually programmable weak pull-ups
 - Ultra Low-power Wake-up (ULPWU)
- Analog comparator module with:
 - Two analog comparators
 - Programmable on-chip voltage reference (CVREF) module (% of VDD)
 - Comparator inputs and outputs externally accessible
- A/D Converter:
 - 10-bit resolution and 8 channels
- Timer0: 8-bit timer/counter with 8-bit programmable prescaler
- Enhanced Timer1:
 - 16-bit timer/counter with prescaler
 - External Gate Input mode
 - Option to use OSC1 and OSC2 in LP mode as Timer1 oscillator if INTOSC mode selected
- Timer2: 8-bit timer/counter with 8-bit period register, prescaler and postscaler
- Enhanced Capture, Compare, PWM module:
 - 16-bit Capture, max resolution 12.5 ns
 - Compare, max resolution 200 ns
 - 10-bit PWM with 1, 2 or 4 output channels, programmable "dead time", max frequency 20 kHz
- In-Circuit Serial Programming™ (ICSP™) via two pins

Device	Program Memory	Data Memory		I/O	10-bit A/D (ch)	Comparators	Timers 8/16-bit
	Flash (words)	SRAM (bytes)	EEPROM (bytes)				
PIC16F684	2048	128	256	12	8	2	2/1

PIC16F684

Pin Diagram

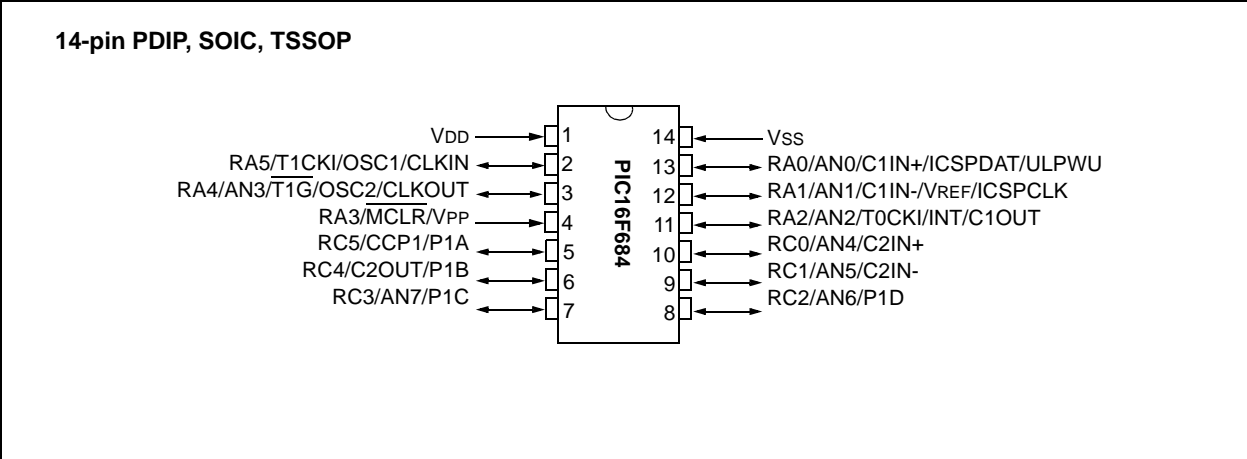

Table of Contents

1.0	Device Overview	5
2.0	Memory Organization	7
3.0	Clock Sources	19
4.0	I/O Ports	31
5.0	Timer0 Module	45
6.0	Timer1 Module with Gate Control.....	49
7.0	Timer2 Module	53
8.0	Comparator Module.....	55
9.0	Analog-to-Digital Converter (A/D) Module.....	63
10.0	Data EEPROM Memory	71
11.0	Enhanced Capture/Compare/PWM (ECCP) Module.....	75
12.0	Special Features of the CPU.....	91
13.0	Instruction Set Summary	111
14.0	Development Support.....	121
15.0	Electrical Specifications.....	127
16.0	DC and AC Characteristics Graphs and Tables.....	147
17.0	Packaging Information.....	149
Appendix A: Data Sheet Revision History		153
Appendix B: Migrating from other PICmicro® Devices		153
Index		155
On-Line Support.....		159
Systems Information and Upgrade Hot Line		159
Reader Response		160
Product Identification System		161

TO OUR VALUED CUSTOMERS

It is our intention to provide our valued customers with the best documentation possible to ensure successful use of your Microchip products. To this end, we will continue to improve our publications to better suit your needs. Our publications will be refined and enhanced as new volumes and updates are introduced.

If you have any questions or comments regarding this publication, please contact the Marketing Communications Department via E-mail at docerrors@mail.microchip.com or fax the **Reader Response Form** in the back of this data sheet to (480) 792-4150. We welcome your feedback.

Most Current Data Sheet

To obtain the most up-to-date version of this data sheet, please register at our Worldwide Web site at:

<http://www.microchip.com>

You can determine the version of a data sheet by examining its literature number found on the bottom outside corner of any page. The last character of the literature number is the version number, (e.g., DS30000A is version A of document DS30000).

Errata

An errata sheet, describing minor operational differences from the data sheet and recommended workarounds, may exist for current devices. As device/documentation issues become known to us, we will publish an errata sheet. The errata will specify the revision of silicon and revision of document to which it applies.

To determine if an errata sheet exists for a particular device, please check with one of the following:

- Microchip's Worldwide Web site; <http://www.microchip.com>
- Your local Microchip sales office (see last page)
- The Microchip Corporate Literature Center; U.S. FAX: (480) 792-7277

When contacting a sales office or the literature center, please specify which device, revision of silicon and data sheet (include literature number) you are using.

Customer Notification System

Register on our web site at www.microchip.com/cn to receive the most current information on all of our products.

PIC16F684

NOTES:

1.0 DEVICE OVERVIEW

This document contains device specific information for the PIC16F684. Additional information may be found in the "PICmicro® Mid-Range MCU Family Reference Manual" (DS33023), which may be obtained from your local Microchip Sales Representative or downloaded from the Microchip web site.

The reference manual should be considered a complementary document to this data sheet and is highly recommended reading for a better understanding of the device architecture and operation of the peripheral modules.

The PIC16F684 is covered by this data sheet. It is available in 14-pin PDIP, SOIC and TSSOP packages. Figure 1-1 shows a block diagram of the PIC16F684 device. Table 1-1 shows the pinout description.

FIGURE 1-1: PIC16F684 BLOCK DIAGRAM

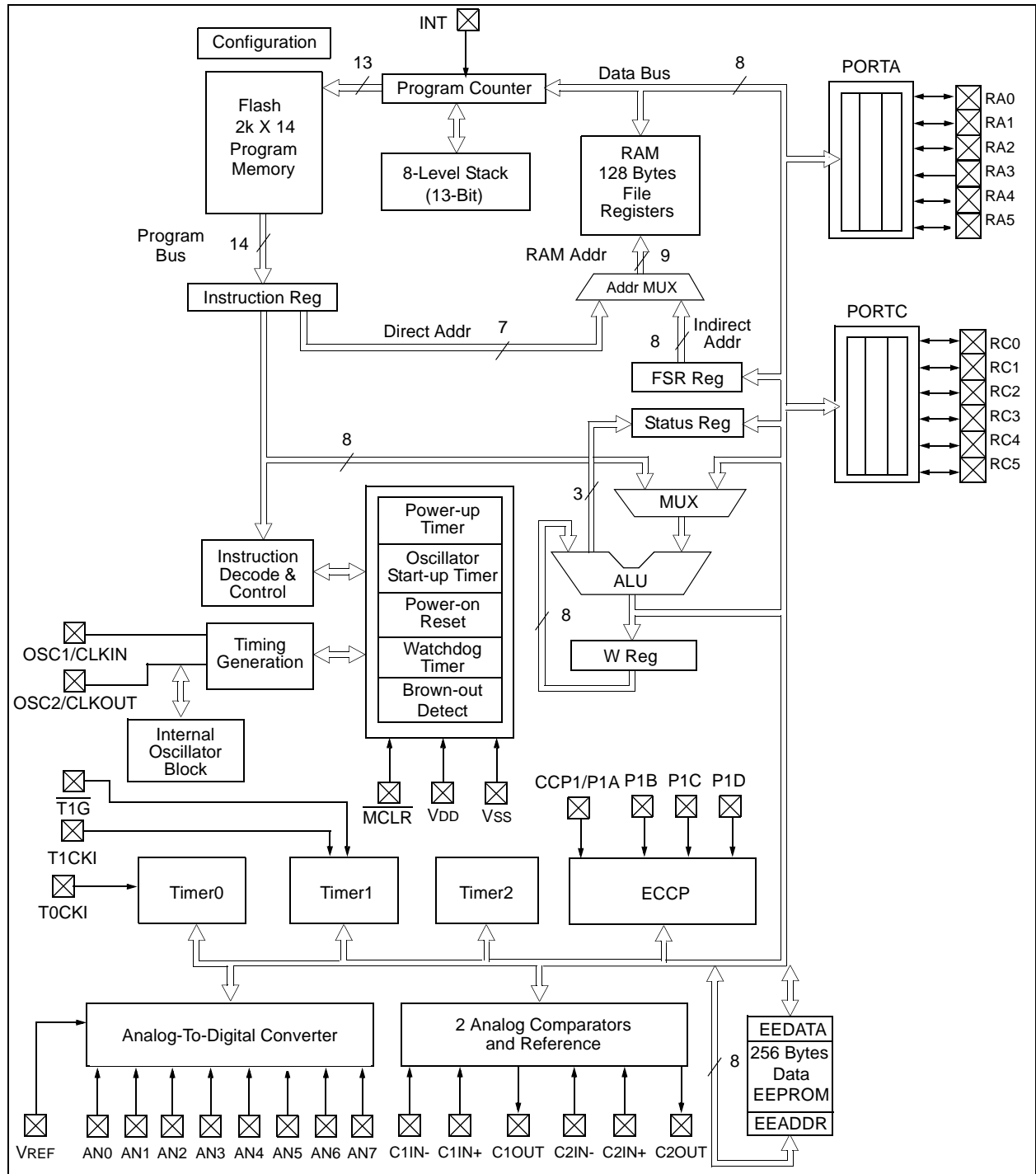

PIC16F684

TABLE 1-1: PIC16F684 PINOUT DESCRIPTION

Name	Function	Input Type	Output Type	Description
RA0/AN0/C1IN+/ICSPDAT/ULPWU	RA0	TTL	CMOS	PORTA I/O w/programmable pull-up and interrupt-on-change
	AN0	AN	—	A/D Channel 0 input
	C1IN+	AN	—	Comparator 1 input
	ICSPDAT	TTL	CMOS	Serial Programming Data I/O
	ULPWU	AN	—	Ultra Low-power Wake-up input
RA1/AN1/C1IN-/VREF/ICSPCLK	RA1	TTL	CMOS	PORTA I/O w/programmable pull-up and interrupt-on-change
	AN1	AN	—	A/D Channel 1 input
	C1IN-	AN	—	Comparator 1 input
	VREF	AN	—	External Voltage Reference for A/D
	ICSPCLK	ST	—	Serial Programming Clock
RA2/AN2/T0CKI/INT/C1OUT	RA2	ST	CMOS	PORTA I/O w/programmable pull-up and interrupt-on-change
	AN2	AN	—	A/D Channel 2 input
	T0CKI	ST	—	Timer0 clock input
	INT	ST	—	External Interrupt
	C1OUT	—	CMOS	Comparator 1 output
RA3/MCLR/VPP	RA3	TTL	—	PORTA input with interrupt-on-change
	MCLR	ST	—	Master Clear w/internal pull-up
	VPP	HV	—	Programming voltage
RA4/AN3/T1G/OSC2/CLKOUT	RA4	TTL	CMOS	PORTA I/O w/programmable pull-up and interrupt-on-change
	AN3	AN	—	A/D Channel 3 input
	T1G	ST	—	Timer1 gate
	OSC2	—	XTAL	Crystal/Resonator
	CLKOUT	—	CMOS	Fosc/4 output
RA5/T1CKI/OSC1/CLKIN	RA5	TTL	CMOS	PORTA I/O w/programmable pull-up and interrupt-on-change
	T1CKI	ST	—	Timer1 clock
	OSC1	XTAL	—	Crystal/Resonator
	CLKIN	ST	—	External clock input/RC oscillator connection
RC0/AN4/C2IN+	RC0	TTL	CMOS	PORTC I/O
	AN4	AN	—	A/D Channel 4 input
	C2IN+	AN	—	Comparator 2 input
RC1/AN5/C2IN-	RC1	TTL	CMOS	PORTC I/O
	AN5	AN	—	A/D Channel 5 input
	C2IN-	AN	—	Comparator 2 input
RC2/AN6/P1D	RC2	TTL	CMOS	PORTC I/O
	AN6	AN	—	A/D Channel 6 input
	P1D	—	CMOS	PWM output
RC3/AN7/P1C	RC3	TTL	CMOS	PORTC I/O
	AN7	AN	—	A/D Channel 7 input
	P1C	—	CMOS	PWM output
RC4/C2OUT/P1B	RC4	TTL	CMOS	PORTC I/O
	C2OUT	—	CMOS	Comparator 2 output
	P1B	—	CMOS	PWM output
RC5/CCP1/P1A	RC5	TTL	CMOS	PORTC I/O
	CCP1	ST	CMOS	Capture input/Compare output
	P1A	—	CMOS	PWM output
Vss	Vss	Power	—	Ground reference
VDD	VDD	Power	—	Positive supply

Legend: TTL = TTL input buffer, ST = Schmitt Trigger input buffer, AN = Analog input

2.0 MEMORY ORGANIZATION

2.1 Program Memory Organization

The PIC16F684 has a 13-bit program counter capable of addressing an 8k x 14 program memory space. Only the first 2k x 14 (0000h-07FFh) for the PIC16F684 is physically implemented. Accessing a location above these boundaries will cause a wrap around within the first 2k x 14 space. The Reset vector is at 0000h and the interrupt vector is at 0004h (see Figure 2-1).

FIGURE 2-1: PROGRAM MEMORY MAP AND STACK FOR THE PIC16F684

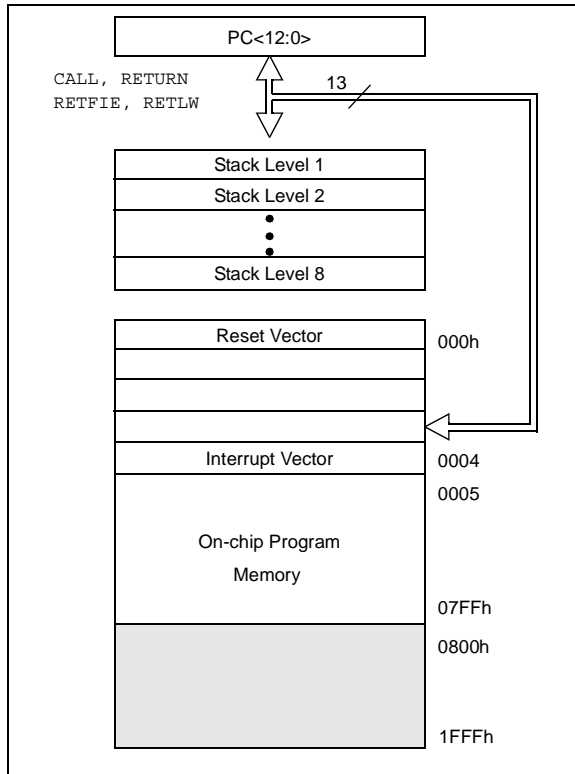

2.2 Data Memory Organization

The data memory (see Figure 2-2) is partitioned into two banks, which contain the General Purpose Registers (GPR) and the Special Function Registers (SFR). The Special Function Registers are located in the first 32 locations of each bank. Register locations 20h-7Fh in Bank 0 and A0h-BFh in Bank 1 are General Purpose Registers, implemented as static RAM. Register locations F0h-FFh in Bank 1 point to addresses 70h-7Fh in Bank 0. All other RAM is unimplemented and returns '0' when read. RP0 (Status<5>) is the bank select bit.

RP0 = 0 : → Bank 0 is selected

RP0 = 1 : → Bank 1 is selected

Note: The IRP and RP1 bits Status<7:6> are reserved and should always be maintained as '0's.

PIC16F684

2.2.1 GENERAL PURPOSE REGISTER FILE

The register file is organized as 128 x 8 in the PIC16F684. Each register is accessed, either directly or indirectly, through the File Select Register (FSR) (see **Section 2.4 “Indirect Addressing, INDF and FSR Registers”**).

2.2.2 SPECIAL FUNCTION REGISTERS

The Special Function Registers are registers used by the CPU and peripheral functions for controlling the desired operation of the device (see Table 2-1). These registers are static RAM.

The special registers can be classified into two sets: core and peripheral. The Special Function Registers associated with the “core” are described in this section. Those related to the operation of the peripheral features are described in the section of that peripheral feature.

FIGURE 2-2: DATA MEMORY MAP OF THE PIC16F684

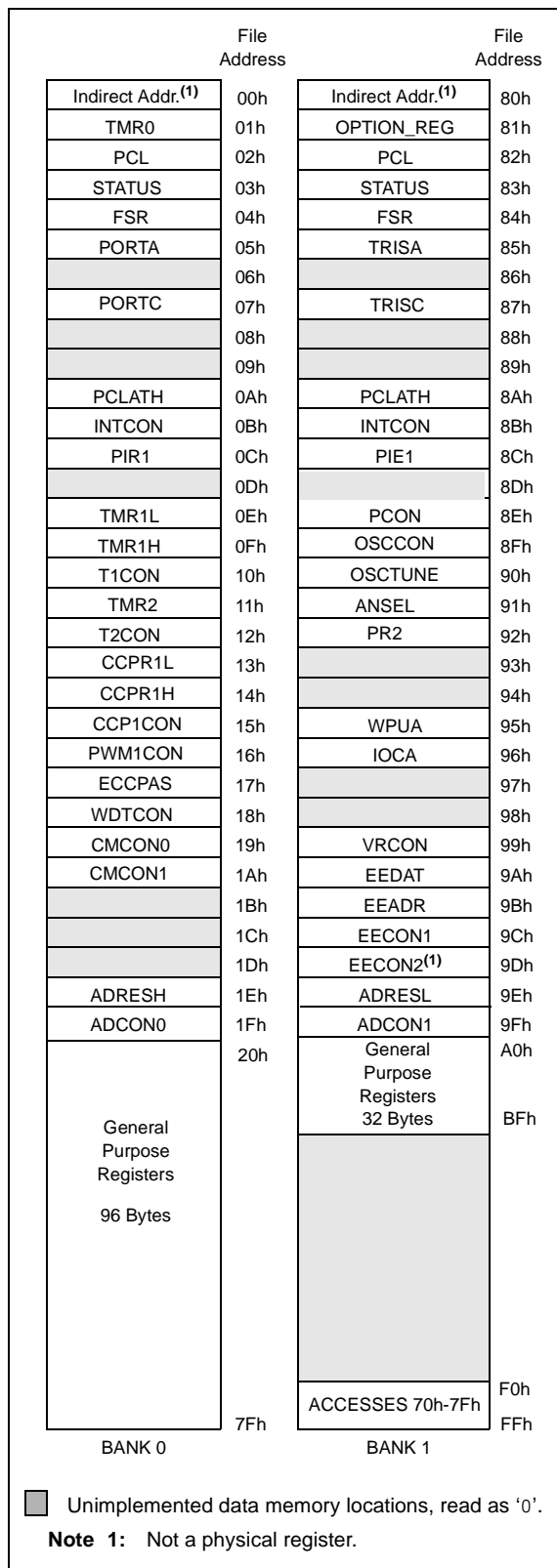

TABLE 2-1: PIC16F684 SPECIAL REGISTERS SUMMARY BANK 0

Addr	Name	Bit 7	Bit 6	Bit 5	Bit 4	Bit 3	Bit 2	Bit 1	Bit 0	Value on POR, BOD	Page
Bank 0											
00h	INDF	Addressing this location uses contents of FSR to address data memory (not a physical register)								xxxx xxxx	17, 99
01h	TMR0	Timer0 Module's register								xxxx xxxx	45, 99
02h	PCL	Program Counter's (PC) Least Significant Byte								0000 0000	17, 99
03h	STATUS	IRP ⁽¹⁾	RP1 ⁽¹⁾	RP0	\overline{TO}	PD	Z	DC	C	0001 1xxxx	11, 99
04h	FSR	Indirect Data Memory Address Pointer								xxxx xxxx	17, 99
05h	PORTA	—	—	RA5	RA4	RA3	RA2	RA1	RA0	--xx xxxxx	31, 99
06h	—	Unimplemented								—	—
07h	PORTC	—	—	RC5	RC4	RC3	RC2	RC1	RC0	--xx xxxxx	40, 99
08h	—	Unimplemented								—	—
09h	—	Unimplemented								—	—
0Ah	PCLATH	—	—	—	Write Buffer for upper 5 bits of Program Counter				---0 0000	17, 99	
0Bh	INTCON	GIE	PEIE	TOIE	INTE	RAIE	TOIF	INTF	RAIF	0000 0000	13, 99
0Ch	PIR1	EEIF	ADIF	CCP1IF	C2IF	C1IF	OSFIF	TMR2IF	TMR1IF	0000 0000	15, 99
0Dh	—	Unimplemented								—	—
0Eh	TMR1L	Holding Register for the Least Significant Byte of the 16-bit TMR1								xxxx xxxx	49, 99
0Fh	TMR1H	Holding Register for the Most Significant Byte of the 16-bit TMR1								xxxx xxxx	49, 99
10h	T1CON	T1GINV	TMR1GE	T1CKPS1	T1CKPS0	T1OSCEN	$\overline{T1SYNC}$	TMR1CS	TMR1ON	0000 0000	51, 99
11h	TMR2	Timer2 Module register								0000 0000	53, 99
12h	T2CON	—	TOUTPS3	TOUTPS2	TOUTPS1	TOUTPS0	TMR2ON	T2CKPS1	T2CKPS0	-000 0000	53, 99
13h	CCPR1L	Capture/Compare/PWM Register 1 Low Byte								XXXX XXXX	75, 99
14h	CCPR1H	Capture/Compare/PWM Register 1 High Byte								XXXX XXXX	75, 99
15h	CCP1CON	P1M1	P1M0	DC1B1	DC1B0	CCP1M3	CCP1M2	CCP1M1	CCP1M0	0000 0000	75, 99
16h	PWM1CON	PRSEN	PDC6	PDC5	PDC4	PDC3	PDC2	PDC1	PDC0	0000 0000	85, 99
17h	ECCPAS	ECCPASE	ECCPAS2	ECCPAS1	ECCPAS0	PSSAC1	PSSAC0	PSSBD1	PSSBD0	0000 0000	86, 99
18h	WDTCN	—	—	—	WDTPS3	WDTPS2	WDTPS1	WDTPS0	SWDTEN	---0 1000	106, 99
19h	CMCON0	C2OUT	C1OUT	C2INV	C1INV	CIS	CM2	CM1	CM0	0000 0000	55, 99
1Ah	CMCON1	—	—	—	—	—	—	T1GSS	C2SYNC	---- --10	59, 99
1Bh	—	Unimplemented								—	—
1Ch	—	Unimplemented								—	—
1Dh	—	Unimplemented								—	—
1Eh	ADRESH	Most Significant 8 bits of the left shifted A/D result or 2 bits of right shifted result								xxxx xxxx	65, 99
1Fh	ADCON0	ADFM	VCFG	—	CHS2	CHS1	CHS0	GO/DONE	ADON	00-0 0000	66, 99

Legend: — = Unimplemented locations read as '0', u = unchanged, x = unknown, q = value depends on condition, shaded = unimplemented

Note 1: IRP and RP1 bits are reserved, always maintain these bits clear.

PIC16F684

TABLE 2-2: PIC16F684 SPECIAL FUNCTION REGISTERS SUMMARY BANK 1

Addr	Name	Bit 7	Bit 6	Bit 5	Bit 4	Bit 3	Bit 2	Bit 1	Bit 0	Value on POR, BOD	Page
Bank 1											
80h	INDF	Addressing this location uses contents of FSR to address data memory (not a physical register)								xxxx xxxx	17, 99
81h	OPTION_REG	RAPU	INTEDG	T0CS	T0SE	PSA	PS2	PS1	PS0	1111 1111	12, 99
82h	PCL	Program Counter's (PC) Least Significant Byte								0000 0000	17, 99
83h	STATUS	IRP ⁽¹⁾	RP1 ⁽¹⁾	RP0	T0	PD	Z	DC	C	0001 1xxx	11, 99
84h	FSR	Indirect Data Memory Address Pointer								xxxx xxxx	17, 99
85h	TRISA	—	—	TRISA5	TRISA4	TRISA3	TRISA2	TRISA1	TRISA0	--11 1111	32, 99
86h	—	Unimplemented								—	—
87h	TRISC	—	—	TRISC5	TRISC4	TRISC3	TRISC2	TRISC1	TRISC0	--11 1111	43, 99
88h	—	Unimplemented								—	—
89h	—	Unimplemented								—	—
8Ah	PCLATH	—	—	—	Write Buffer for upper 5 bits of Program Counter				---	0 0000	17, 99
8Bh	INTCON	GIE	PEIE	TOIE	INTE	RAIE	TOIF	INTF	RAIF	0000 0000	13, 99
8Ch	PIE1	EEIE	ADIE	CCP1IE	C2IE	C1IE	OSFIE	TMR2IE	TMR1IE	0000 0000	14, 99
8Dh	—	Unimplemented								—	—
8Eh	PCON	—	—	ULPWUE	SBODEN	—	—	POR	BOD	--01 --qq	16, 99
8Fh	OSCCON	—	IRCF2	IRCF1	IRCF0	OSTS ⁽²⁾	HTS	LTS	SCS	-110 x000	29, 99
90h	OSCTUNE	—	—	—	TUN4	TUN3	TUN2	TUN1	TUN0	---0 0000	23, 99
91h	ANSEL	ANS7	ANS6	ANS5	ANS4	ANS3	ANS2	ANS1	ANS0	1111 1111	65, 99
92h	PR2	Timer2 Module Period Register								1111 1111	53, 99
93h	—	Unimplemented								—	—
94h	—	Unimplemented								—	—
95h	WPUA ⁽³⁾	—	—	WPUA5	WPUA4	—	WPUA2	WPUA1	WPUA0	--11 -111	32, 100
96h	IOCA	—	—	IOCA5	IOCA4	IOCA3	IOCA2	IOCA1	IOCA0	--00 0000	33, 100
97h	—	Unimplemented								—	—
98h	—	Unimplemented								—	—
99h	VRCON	VREN	—	VRR	—	VR3	VR2	VR1	VR0	0-0- 0000	62, 100
9Ah	EEDAT	EEDAT7	EEDAT6	EEDAT5	EEDAT4	EEDAT3	EEDAT2	EEDAT1	EEDAT0	0000 0000	71, 100
9Bh	EEADR	EEADR7	EEADR6	EEADR5	EEADR4	EEADR3	EEADR2	EEADR1	EEADR0	0000 0000	71, 100
9Ch	EECON1	—	—	—	—	WRERR	WREN	WR	RD	---- x000	72, 100
9Dh	EECON2	EEPROM Control Register 2 (not a physical register)								---- ----	72, 100
9Eh	ADRESL	Least Significant 2 bits of the left shifted result or 8 bits of the right shifted result								xxxx xxxx	65, 100
9Fh	ADCON1	—	ADCS2	ADCS1	ADCS0	—	—	—	—	-000 ----	66, 100

Legend: — = Unimplemented locations read as '0', u = unchanged, x = unknown, q = value depends on condition, shaded = unimplemented

Note 1: IRP and RP1 bits are reserved, always maintain these bits clear.

Note 2: OSTS bit OSCCON <3> reset to '0' with Dual Speed Start-up and LP, HS or XT selected as the oscillator.

Note 3: RA3 pull-up is enabled when MCLRE is '1' in the Configuration Word register.

2.2.2.1 Status Register

The Status register, shown in Register 2-1, contains:

- the arithmetic status of the ALU
- the Reset status
- the bank select bits for data memory (SRAM)

The Status register can be the destination for any instruction, like any other register. If the Status register is the destination for an instruction that affects the Z, DC or C bits, then the write to these three bits is disabled. These bits are set or cleared according to the device logic. Furthermore, the $\overline{\text{TO}}$ and PD bits are not writable. Therefore, the result of an instruction with the Status register as destination may be different than intended.

For example, `CLRF STATUS`, will clear the upper three bits and set the Z bit. This leaves the Status register as '000u u1uu' (where u = unchanged).

It is recommended, therefore, that only `BCF`, `BSF`, `SWAPF` and `MOVWF` instructions are used to alter the Status register, because these instructions do not affect any Status bits. For other instructions not affecting any Status bits, see the "Instruction Set Summary".

Note 1: Bits IRP and RP1 (Status<7:6>) are not used by the PIC16F684 and should be maintained as clear. Use of these bits is not recommended, since this may affect upward compatibility with future products.

2: The C and DC bits operate as a Borrow and Digit Borrow out bit, respectively, in subtraction. See the `SUBLW` and `SUBWF` instructions for examples.

REGISTER 2-1: STATUS – STATUS REGISTER (ADDRESS: 03h OR 83h)

Reserved	Reserved	R/W-0	R-1	R-1	R/W-x	R/W-x	R/W-x	
IRP	RP1	RP0	$\overline{\text{TO}}$	PD	Z	DC	C	
bit 7								bit 0

- bit 7 **IRP:** This bit is reserved and should be maintained as '0'
- bit 6 **RP1:** This bit is reserved and should be maintained as '0'
- bit 5 **RP0:** Register Bank Select bit (used for direct addressing)
1 = Bank 1 (80h – FFh)
0 = Bank 0 (00h – 7Fh)
- bit 4 **$\overline{\text{TO}}$:** Time-out bit
1 = After power-up, `CLRWDT` instruction or `SLEEP` instruction
0 = A WDT time-out occurred
- bit 3 **PD:** Power-down bit
1 = After power-up or by the `CLRWDT` instruction
0 = By execution of the `SLEEP` instruction
- bit 2 **Z:** Zero bit
1 = The result of an arithmetic or logic operation is zero
0 = The result of an arithmetic or logic operation is not zero
- bit 1 **DC:** Digit carry/borrow bit (`ADDWF`, `ADDLW`, `SUBLW`, `SUBWF` instructions)
For borrow, the polarity is reversed.
1 = A carry-out from the 4th low-order bit of the result occurred
0 = No carry-out from the 4th low-order bit of the result
- bit 0 **C:** Carry/borrow bit (`ADDWF`, `ADDLW`, `SUBLW`, `SUBWF` instructions)
1 = A carry-out from the Most Significant bit of the result occurred
0 = No carry-out from the Most Significant bit of the result occurred

Note 1: For borrow, the polarity is reversed. A subtraction is executed by adding the two's complement of the second operand. For rotate (`RRF`, `RLF`) instructions, this bit is loaded with either the high-order or low-order bit of the source register.

Legend:

R = Readable bit W = Writable bit U = Unimplemented bit, read as '0'
-n = Value at POR '1' = Bit is set '0' = Bit is cleared x = Bit is unknown

PIC16F684

2.2.2.2 Option Register

The Option register is a readable and writable register, which contains various control bits to configure:

- TMR0/WDT prescaler
- External RA2/INT interrupt
- TMR0
- Weak pull-ups on PORTA

Note: To achieve a 1:1 prescaler assignment for TMR0, assign the prescaler to the WDT by setting PSA bit to '1' (OPTION_REG<3>). See **Section 5.4 "Prescaler"**.

REGISTER 2-2: OPTION_REG – OPTION REGISTER (ADDRESS: 81h)

	R/W-1	R/W-1	R/W-1	R/W-1	R/W-1	R/W-1	R/W-1	R/W-1
	RAPU	INTEDG	T0CS	T0SE	PSA	PS2	PS1	PS0
bit 7								bit 0

- bit 7 **RAPU:** PORTA Pull-up Enable bit
 1 = PORTA pull-ups are disabled
 0 = PORTA pull-ups are enabled by individual port latch values
- bit 6 **INTEDG:** Interrupt Edge Select bit
 1 = Interrupt on rising edge of RA2/INT pin
 0 = Interrupt on falling edge of RA2/INT pin
- bit 5 **T0CS:** TMR0 Clock Source Select bit
 1 = Transition on RA2/T0CKI pin
 0 = Internal instruction cycle clock (CLKOUT)
- bit 4 **T0SE:** TMR0 Source Edge Select bit
 1 = Increment on high-to-low transition on RA2/T0CKI pin
 0 = Increment on low-to-high transition on RA2/T0CKI pin
- bit 3 **PSA:** Prescaler Assignment bit
 1 = Prescaler is assigned to the WDT
 0 = Prescaler is assigned to the Timer0 module
- bit 2-0 **PS<2:0>:** Prescaler Rate Select bits

BIT VALUE	TMR0 RATE	WDT RATE
000	1 : 2	1 : 1
001	1 : 4	1 : 2
010	1 : 8	1 : 4
011	1 : 16	1 : 8
100	1 : 32	1 : 16
101	1 : 64	1 : 32
110	1 : 128	1 : 64
111	1 : 256	1 : 128

Legend:
 R = Readable bit W = Writable bit U = Unimplemented bit, read as '0'
 -n = Value at POR '1' = Bit is set '0' = Bit is cleared x = Bit is unknown

2.2.2.3 INTCON Register

The INTCON register is a readable and writable register, which contains the various enable and flag bits for TMR0 register overflow, PORTA change and external RA2/INT pin interrupts.

Note: Interrupt flag bits are set when an interrupt condition occurs, regardless of the state of its corresponding enable bit or the global enable bit, GIE (INTCON<7>). User software should ensure the appropriate interrupt flag bits are clear prior to enabling an interrupt.

REGISTER 2-3: INTCON – INTERRUPT CONTROL REGISTER (ADDRESS: 0Bh OR 8Bh)

R/W-0	R/W-0	R/W-0	R/W-0	R/W-0	R/W-0	R/W-0	R/W-0
GIE	PEIE	TOIE	INTE	RAIE	T0IF	INTF	RAIF
						bit 0	

- bit 7 **GIE:** Global Interrupt Enable bit
1 = Enables all unmasked interrupts
0 = Disables all interrupts
- bit 6 **PEIE:** Peripheral Interrupt Enable bit
1 = Enables all unmasked peripheral interrupts
0 = Disables all peripheral interrupts
- bit 5 **TOIE:** TMR0 Overflow Interrupt Enable bit
1 = Enables the TMR0 interrupt
0 = Disables the TMR0 interrupt
- bit 4 **INTE:** RA2/INT External Interrupt Enable bit
1 = Enables the RA2/INT external interrupt
0 = Disables the RA2/INT external interrupt
- bit 3 **RAIE:** PORTA Change Interrupt Enable bit⁽¹⁾
1 = Enables the PORTA change interrupt
0 = Disables the PORTA change interrupt
- bit 2 **T0IF:** TMR0 Overflow Interrupt Flag bit⁽²⁾
1 = TMR0 register has overflowed (must be cleared in software)
0 = TMR0 register did not overflow
- bit 1 **INTF:** RA2/INT External Interrupt Flag bit
1 = The RA2/INT external interrupt occurred (must be cleared in software)
0 = The RA2/INT external interrupt did not occur
- bit 0 **RAIF:** PORTA Change Interrupt Flag bit
1 = When at least one of the PORTA <5:0> pins changed state (must be cleared in software)
0 = None of the PORTA <5:0> pins have changed state

Note 1: IOCA register must also be enabled.

2: T0IF bit is set when Timer0 rolls over. Timer0 is unchanged on Reset and should be initialized before clearing T0IF bit.

Legend:

R = Readable bit	W = Writable bit	U = Unimplemented bit, read as '0'
-n = Value at POR	'1' = Bit is set	'0' = Bit is cleared x = Bit is unknown

PIC16F684

2.2.2.4 PIE1 Register

The PIE1 register contains the interrupt enable bits, as shown in Register 2-4.

Note: Bit PEIE (INTCON<6>) must be set to enable any peripheral interrupt.

REGISTER 2-4: PIE1 – PERIPHERAL INTERRUPT ENABLE REGISTER 1 (ADDRESS: 8Ch)

R/W-0	R/W-0	R/W-0	R/W-0	R/W-0	R/W-0	R/W-0	R/W-0
EEIE	ADIE	CCP1IE	C2IE	C1IE	OSFIE	TMR2IE	TMR1IE
bit 7							bit 0

- bit 7 **EEIE:** EE Write Complete Interrupt Enable bit
1 = Enables the EE write complete interrupt
0 = Disables the EE write complete interrupt
- bit 6 **ADIE:** A/D Converter Interrupt Enable bit
1 = Enables the A/D converter interrupt
0 = Disables the A/D converter interrupt
- bit 5 **CCP1IE:** CCP1 Interrupt Enable bit
1 = Enables the CCP1 interrupt
0 = Disables the CCP1 interrupt
- bit 4 **C2IE:** Comparator 2 Interrupt Enable bit
1 = Enables the Comparator 2 interrupt
0 = Disables the Comparator 2 interrupt
- bit 3 **C1IE:** Comparator 1 Interrupt Enable bit
1 = Enables the Comparator 1 interrupt
0 = Disables the Comparator 1 interrupt
- bit 2 **OSFIE:** Oscillator Fail Interrupt Enable bit
1 = Enables the oscillator fail interrupt
0 = Disables the oscillator fail interrupt
- bit 1 **TMR2IE:** Timer2 to PR2 Match Interrupt Enable bit
1 = Enables the Timer2 to PR2 match interrupt
0 = Disables the Timer2 to PR2 match interrupt
- bit 0 **TMR1IE:** Timer1 Overflow Interrupt Enable bit
1 = Enables the Timer1 overflow interrupt
0 = Disables the Timer1 overflow interrupt

Legend:

R = Readable bit	W = Writable bit	U = Unimplemented bit, read as '0'
-n = Value at POR	'1' = Bit is set	'0' = Bit is cleared x = Bit is unknown

2.2.2.5 PIR1 Register

The PIR1 register contains the interrupt flag bits, as shown in Register 2-5.

Note: Interrupt flag bits are set when an interrupt condition occurs, regardless of the state of its corresponding enable bit or the global enable bit, GIE (INTCON<7>). User software should ensure the appropriate interrupt flag bits are clear prior to enabling an interrupt.

REGISTER 2-5: PIR1 – PERIPHERAL INTERRUPT REQUEST REGISTER 1 (ADDRESS: 0Ch)

R/W-0	R/W-0	R/W-0	R/W-0	R/W-0	R/W-0	R/W-0	R/W-0
EEIF	ADIF	CCP1IF	C2IF	C1IF	OSFIF	TMR2IF	TMR1IF

bit 7

bit 0

- bit 7 **EEIF:** EEPROM Write Operation Interrupt Flag bit
 1 = The write operation completed (must be cleared in software)
 0 = The write operation has not completed or has not been started
- bit 6 **ADIF:** A/D Interrupt Flag bit
 1 = A/D conversion complete
 0 = A/D conversion has not completed or has not been started
- bit 5 **CCP1IF:** CCP1 Interrupt Flag bit
Capture mode:
 1 = A TMR1 register capture occurred (must be cleared in software)
 0 = No TMR1 register capture occurred
Compare mode:
 1 = A TMR1 register compare match occurred (must be cleared in software)
 0 = No TMR1 register compare match occurred
PWM mode:
 Unused in this mode
- bit 4 **C2IF:** Comparator 2 Interrupt Flag bit
 1 = Comparator 2 output has changed (must be cleared in software)
 0 = Comparator 2 output has not changed
- bit 3 **C1IF:** Comparator 1 Interrupt Flag bit
 1 = Comparator 1 output has changed (must be cleared in software)
 0 = Comparator 1 output has not changed
- bit 2 **OSFIF:** Oscillator Fail Interrupt Flag bit
 1 = System oscillator failed, clock input has changed to INTOSC (must be cleared in software)
 0 = System clock operating
- bit 1 **TMR2IF:** Timer2 to PR2 Match Interrupt Flag bit
 1 = Timer2 to PR2 match occurred (must be cleared in software)
 0 = Timer2 to PR2 match has not occurred
- bit 0 **TMR1IF:** Timer1 Overflow Interrupt Flag bit
 1 = Timer1 register overflowed (must be cleared in software)
 0 = Timer1 has not overflowed

Legend:

R = Readable bit W = Writable bit U = Unimplemented bit, read as '0'
 -n = Value at POR '1' = Bit is set '0' = Bit is cleared x = Bit is unknown

PIC16F684

2.2.2.6 PCON Register

The Power Control (PCON) register (see Table 12-2) contains flag bits to differentiate between a:

- Power-on Reset ($\overline{\text{POR}}$)
- Brown-out Detect ($\overline{\text{BOD}}$)
- Watchdog Timer Reset (WDT)
- External MCLR Reset

The PCON register also controls the ultra low-power wake-up and software enable of the $\overline{\text{BOD}}$.

The PCON register bits are shown in Register 2-6.

REGISTER 2-6: PCON – POWER CONTROL REGISTER (ADDRESS: 8Eh)

U-0	U-0	R/W-0	R/W-1	U-0	U-0	R/W-0	R/W-x
—	—	ULPWUE	SBODEN	—	—	$\overline{\text{POR}}$	$\overline{\text{BOD}}$
bit 7						bit 0	

bit 7-6 **Unimplemented:** Read as '0'

bit 5 **ULPWUE:** Ultra Low-Power Wake-up Enable bit

1 = Ultra low-power wake-up enabled

0 = Ultra low-power wake-up disabled

bit 4 **SBODEN:** Software BOD Enable bit⁽¹⁾

1 = BOD enabled

0 = BOD disabled

bit 3-2 **Unimplemented:** Read as '0'

bit 1 **$\overline{\text{POR}}$:** Power-on Reset Status bit

1 = No Power-on Reset occurred

0 = A Power-on Reset occurred (must be set in software after a Power-on Reset occurs)

bit 0 **$\overline{\text{BOD}}$:** Brown-out Detect Status bit

1 = No Brown-out Detect occurred

0 = A Brown-out Detect occurred (must be set in software after a Brown-out Detect occurs)

Note 1: BODEN<1:0> = 01 in the Configuration Word register for this bit to control the $\overline{\text{BOD}}$.

Legend:

R = Readable bit

W = Writable bit

U = Unimplemented bit, read as '0'

-n = Value at POR

'1' = Bit is set

'0' = Bit is cleared

x = Bit is unknown

2.3 PCL and PCLATH

The Program Counter (PC) is 13 bits wide. The low byte comes from the PCL register, which is a readable and writable register. The high byte (PC<12:8>) is not directly readable or writable and comes from PCLATH. On any Reset, the PC is cleared. Figure 2-3 shows the two situations for the loading of the PC. The upper example in Figure 2-3 shows how the PC is loaded on a write to PCL (PCLATH<4:0> → PCH). The lower example in Figure 2-3 shows how the PC is loaded during a CALL or GOTO instruction (PCLATH<4:3> → PCH).

FIGURE 2-3: LOADING OF PC IN DIFFERENT SITUATIONS

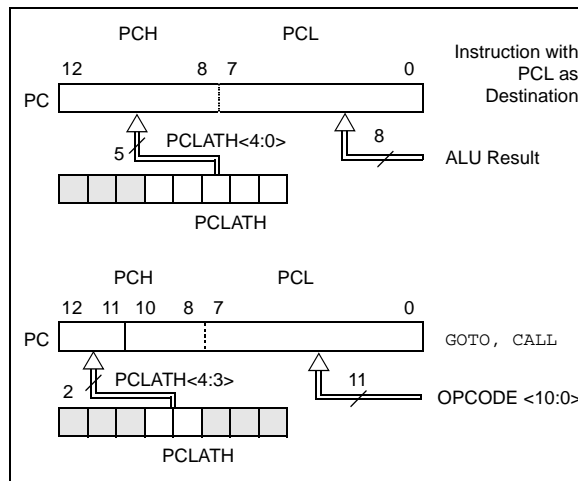

2.3.1 COMPUTED GOTO

A computed GOTO is accomplished by adding an offset to the program counter (ADDWF PCL). When performing a table read using a computed GOTO method, care should be exercised if the table location crosses a PCL memory boundary (each 256-byte block). Refer to the Application Note AN556, "Implementing a Table Read" (DS00556).

2.3.2 STACK

The PIC16F684 Family has an 8-level x 13-bit wide hardware stack (see Figure 2-1). The stack space is not part of either program or data space and the stack pointer is not readable or writable. The PC is PUSHed onto the stack when a CALL instruction is executed or an interrupt causes a branch. The stack is POPed in the event of a RETURN, RETLW or a RETFIE instruction execution. PCLATH is not affected by a PUSH or POP operation.

The stack operates as a circular buffer. This means that after the stack has been PUSHed eight times, the ninth push overwrites the value that was stored from the first push. The tenth push overwrites the second push (and so on).

Note 1: There are no Status bits to indicate stack overflow or stack underflow conditions.

2: There are no instructions/mnemonics called PUSH or POP. These are actions that occur from the execution of the CALL, RETURN, RETLW and RETFIE instructions or the vectoring to an interrupt address.

2.4 Indirect Addressing, INDF and FSR Registers

The INDF register is not a physical register. Addressing the INDF register will cause indirect addressing.

Indirect addressing is possible by using the INDF register. Any instruction using the INDF register actually accesses data pointed to by the File Select Register (FSR). Reading INDF itself indirectly will produce 00h. Writing to the INDF register indirectly results in a no operation (although Status bits may be affected). An effective 9-bit address is obtained by concatenating the 8-bit FSR and the IRP bit (Status<7>), as shown in Figure 2-4.

A simple program to clear RAM location 20h-2Fh using indirect addressing is shown in Example 2-1.

EXAMPLE 2-1: INDIRECT ADDRESSING

```

MOVLW0x20;initialize pointer
MOVWFFSR ;to RAM
NEXT   CLRFINDF ;clear INDF register
       INCFFSR ;INC POINTER
       BTFSSFSR,4;all done?
       GOTONEXT ;no clear next
CONTINUE      ;yes continue
    
```

PIC16F684

FIGURE 2-4: DIRECT/INDIRECT ADDRESSING PIC16F684

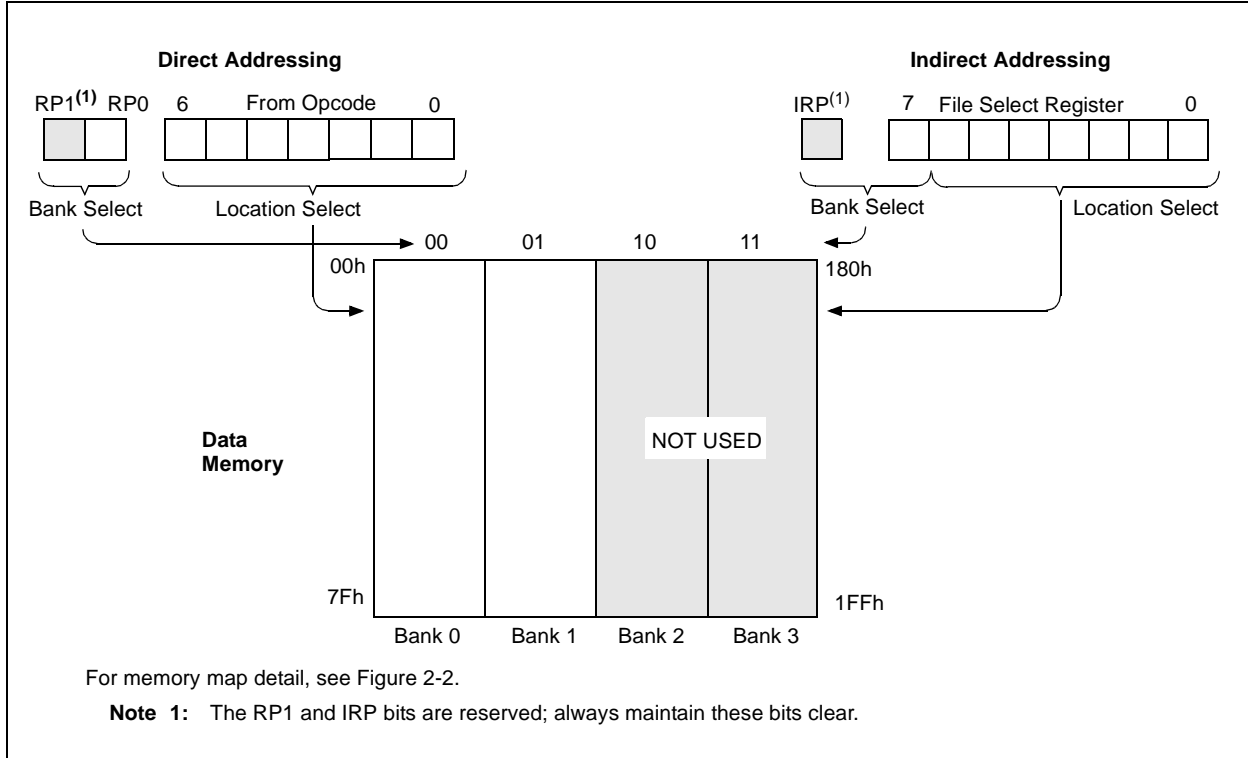

3.0 CLOCK SOURCES

3.1 Overview

The PIC16F684 has a wide variety of clock sources and selection features to allow it to be used in a wide range of applications while maximizing performance and minimizing power consumption. Figure 3-1 illustrates a block diagram of the PIC16F684 clock sources.

Clock sources can be configured from external oscillators, quartz crystal resonators, ceramic resonators and Resistor-Capacitor (RC) circuits. In addition, the system clock source can be configured from one of two internal oscillators, with a choice of speeds selectable via software. Additional clock features include:

- Selectable system clock source between external or internal via software.
- Two-Speed Clock Start-up mode, which minimizes latency between external oscillator start-up and code execution.
- Fail-Safe Clock Monitor (FSCM) designed to detect a failure of the external clock source (LP, XT, HS, EC or RC modes) and switch to the internal oscillator.

The PIC16F684 can be configured in one of eight clock modes.

1. EC – External clock with I/O on RA4.
2. LP – Low gain Crystal or Ceramic Resonator Oscillator mode.
3. XT – Medium gain Crystal or Ceramic Resonator Oscillator mode.
4. HS – High gain Crystal or Ceramic Resonator mode.
5. RC – External Resistor-Capacitor (RC) with FOSC/4 output on RA4.
6. RCIO – External Resistor-Capacitor with I/O on RA4.
7. INTRC – Internal oscillator with FOSC/4 output on RA4 and I/O on RA5.
8. INTRCIO – Internal oscillator with I/O on RA4 and RA5.

Clock source modes are configured by the FOSC<2:0> bits in the Configuration Word register (see **Section 12.0 “Special Features of the CPU”**). The internal clock can be generated by two oscillators. The HFINTOSC is a high-frequency calibrated oscillator. The LFINTOSC is a low-frequency uncalibrated oscillator.

FIGURE 3-1: PIC16F684 CLOCK SOURCE BLOCK DIAGRAM

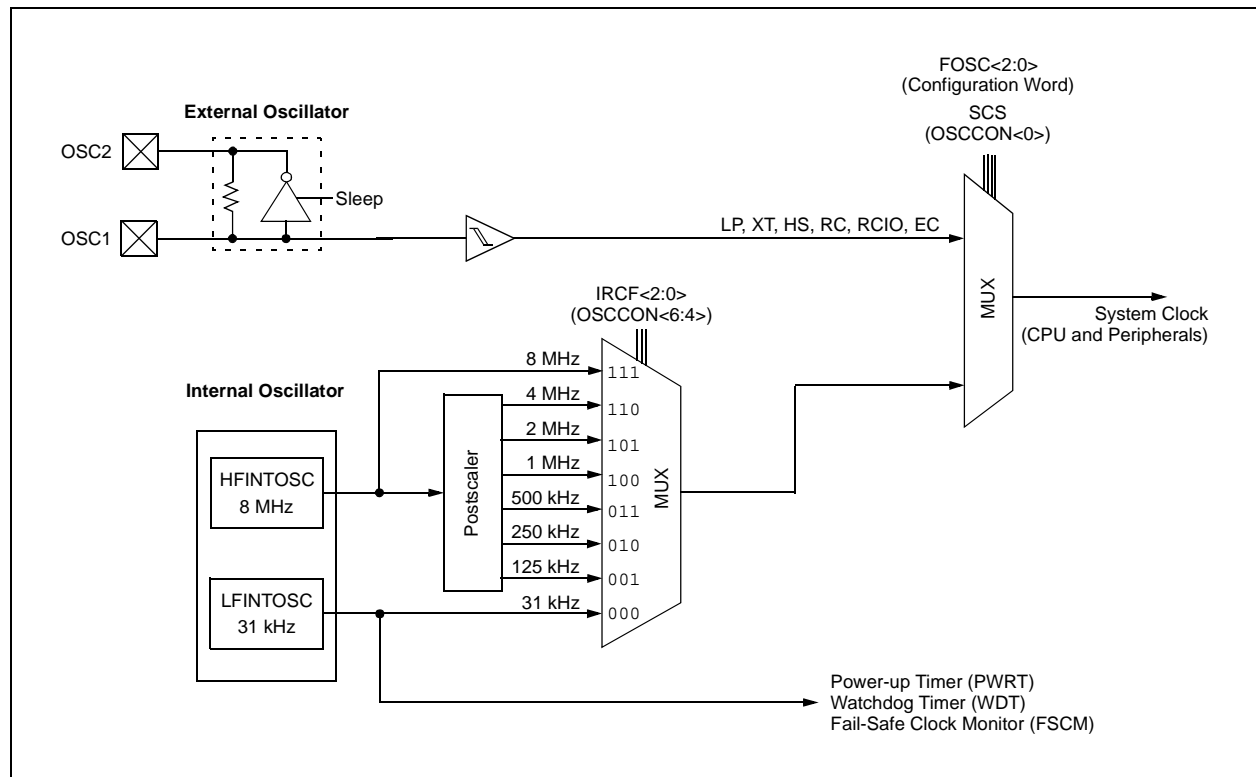

PIC16F684

3.2 Clock Source Modes

Clock source modes can be classified as external or internal.

- External clock modes rely on external circuitry for the clock source. Examples are oscillator modules (EC mode), quartz crystal resonators or ceramic resonators (LP, XT and HS modes), and Resistor-Capacitor (RC mode) circuits.
- Internal clock sources are contained internally within the PIC16F684. The PIC16F684 has two internal oscillators, the 8 MHz High-Frequency Internal Oscillator (HFINTOSC) and 31 kHz Low-Frequency Internal Oscillator (LFINTOSC).

The system clock can be selected between external or internal clock sources via the System Clock Selection (SCS) bit (see **Section 3.5 “Clock Switching”**).

3.3 External Clock Modes

3.3.1 OSCILLATOR START-UP TIMER (OST)

If the PIC16F684 is configured for LP, XT or HS modes, the Oscillator Start-up Timer (OST) counts 1024 oscillations from the OSC1 pin, following a Power-on Reset (POR) and the Power-up Timer (PWRT) has expired (if configured), or a wake-up from Sleep. During this time, the program counter does not increment and program execution is suspended. The OST ensures that the oscillator circuit, using a quartz crystal resonator or ceramic resonator, has started and is providing a stable system clock to the PIC16F684. When switching between clock sources a delay is required to allow the new clock to stabilize. These oscillator delays are shown in Table 3-1.

In order to minimize latency between external oscillator start-up and code execution, the Two-Speed Clock Start-up mode can be selected (see **Section 3.6 “Two-Speed Clock Start-up Mode”**).

TABLE 3-1: OSCILLATOR DELAY EXAMPLES

Switch From	Switch To	Frequency	Oscillator Delay
Sleep/POR	LFINTOSC HFINTOSC	31 kHz 125 kHz to 8 MHz	5 μ s-10 μ s (approx.) CPU Start-up ⁽¹⁾
Sleep/POR	EC, RC	DC – 20 MHz	
LFINTOSC (31 kHz)	EC, RC	DC – 20 MHz	
Sleep/POR	LP, XT, HS	31 kHz to 20 MHz	1024 Clock Cycles (OST)
LFINTOSC (31 kHz)	HFINTOSC	125 kHz to 8 MHz	1 μ s (approx.)

Note 1: The 5 μ s to 10 μ s start-up delay is based on a 1 MHz system clock.

3.3.2 EC MODE

The External Clock (EC) mode allows an externally generated logic level as the system clock source. When operating in this mode, an external clock source is connected to the OSC1 pin and the RA5 pin is available for general purpose I/O. Figure 3-2 shows the pin connections for EC mode.

The Oscillator Start-up Timer (OST) is disabled when EC mode is selected. Therefore, there is no delay in operation after a Power-on Reset (POR) or wake-up from Sleep. Because the PIC16F684 design is fully static, stopping the external clock input will have the effect of halting the device while leaving all data intact. Upon restarting the external clock, the device will resume operation as if no time had elapsed.

FIGURE 3-2: EXTERNAL CLOCK (EC) MODE OPERATION

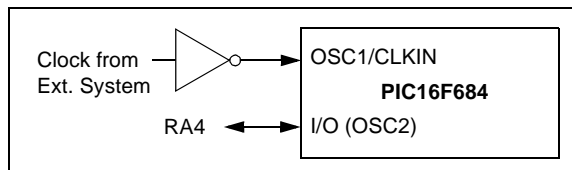

3.3.3 LP, XT, HS MODES

The LP, XT and HS modes support the use of quartz crystal resonators or ceramic resonators connected to the OSC1 and OSC2 pins (Figure 3-1). The mode selects a low, medium or high gain setting of the internal inverter-amplifier to support various resonator types and speed.

LP Oscillator mode selects the lowest gain setting of the internal inverter-amplifier. LP mode current consumption is the least of the three modes. This mode is best suited to drive resonators with a low drive level specification, for example, tuning fork type crystals.

XT Oscillator mode selects the intermediate gain setting of the internal inverter-amplifier. XT mode current consumption is the medium of the three modes. This mode is best suited to drive resonators with a medium drive level specification, for example, low-frequency/AT-cut quartz crystal resonators.

HS Oscillator mode selects the highest gain setting of the internal inverter-amplifier. HS mode current consumption is the highest of the three modes. This mode is best suited for resonators that require a high drive setting, for example, high-frequency/AT-cut quartz crystal resonators or ceramic resonators.

Figure 3-3 and Figure 3-4 show typical circuits for quartz crystal and ceramic resonators, respectively.

FIGURE 3-4: CERAMIC RESONATOR OPERATION (XT OR HS MODE)

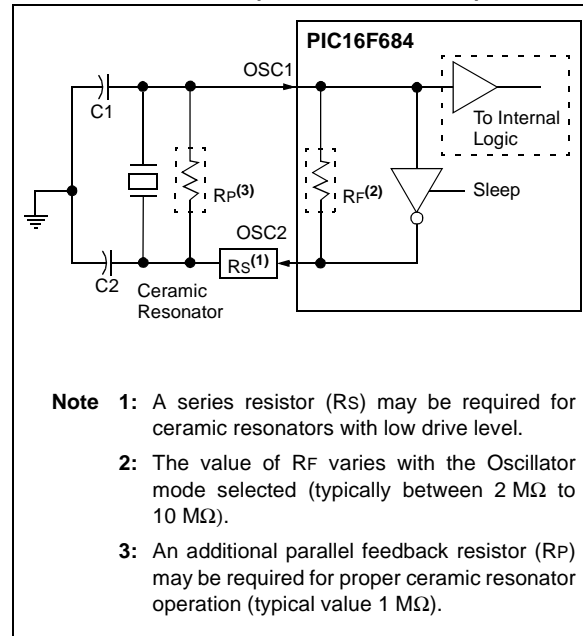
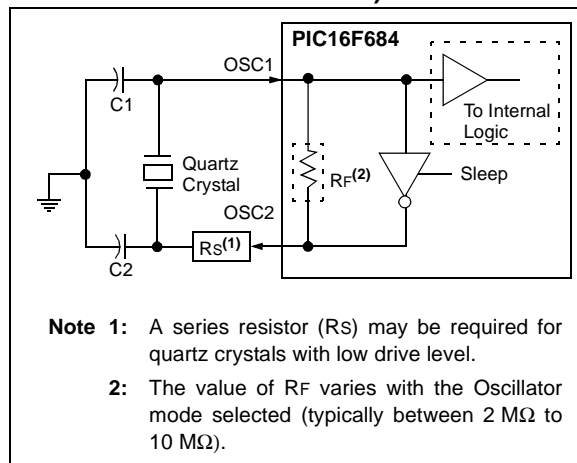

FIGURE 3-3: QUARTZ CRYSTAL OPERATION (LP, XT OR HS MODE)



Note 1: Quartz crystal characteristics vary according to type, package and manufacturer. The user should consult the manufacturer data sheets for specifications and recommended application.

Note 2: Always verify oscillator performance over the V_{DD} and temperature range that is expected for the application.

PIC16F684

3.3.4 EXTERNAL RC MODES

The External Resistor-Capacitor (RC) modes support the use of an external RC circuit. This allows the designer maximum flexibility in frequency choice while keeping costs to a minimum when clock accuracy is not required. There are two modes, RC and RCIO.

In RC mode, the RC circuit connects to the OSC1 pin. The OSC2/CLKOUT pin outputs the RC oscillator frequency divided by 4. This signal may be used to provide a clock for external circuitry, synchronization, calibration, test or other application requirements. Figure 3-5 shows the RC mode connections.

FIGURE 3-5: RC MODE

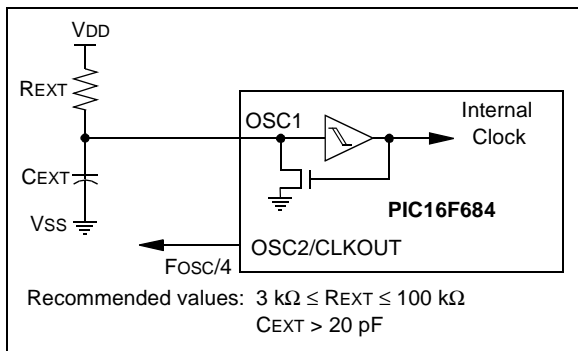

In RCIO mode, the RC circuit is connected to the OSC1 pin. The OSC2 pin becomes an additional general purpose I/O pin. The I/O pin becomes bit 4 of PORTA (RA4). Figure 3-6 shows the RCIO mode connections.

FIGURE 3-6: RCIO MODE

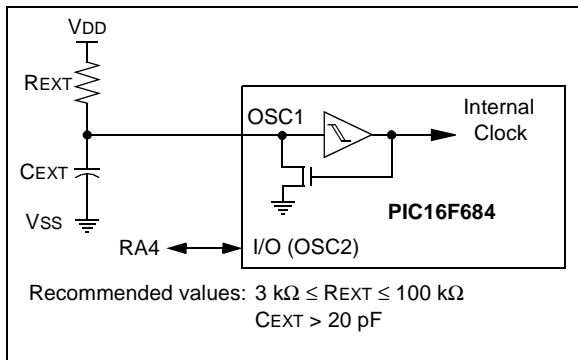

The RC oscillator frequency is a function of the supply voltage, the resistor (R_{EXT}) and capacitor (C_{EXT}) values and the operating temperature. Other factors affecting the oscillator frequency are:

- threshold voltage variation
- component tolerances
- packaging variations in capacitance

The user also needs to take into account variation due to tolerance of external RC components used.

3.4 Internal Clock Modes

The PIC16F684 has two independent, internal oscillators that can be configured or selected as the system clock source.

1. The **HFINTOSC** (High-Frequency Internal Oscillator) is factory calibrated and operates at 8 MHz. The frequency of the HFINTOSC can be user adjusted $\pm 12\%$ via software using the OSCTUNE register (Register 3-1).
2. The **LFINTOSC** (Low-Frequency Internal Oscillator) is uncalibrated and operates at approximately 31 kHz.

The system clock speed can be selected via software using the Internal Oscillator Frequency Select (IRCF) bits.

The system clock can be selected between external or internal clock sources via the System Clock Selection (SCS) bit (see **Section 3.5 “Clock Switching”**).

3.4.1 INTRC AND INTRCIO MODES

The INTRC and INTRCIO modes configure the internal oscillators as the system clock source when the device is programmed using the Oscillator Selection (FOSC) bits in the Configuration Word register (Register 12-1).

In **INTRC** mode, the OSC1 pin is available for general purpose I/O. The OSC2/CLKOUT pin outputs the selected internal oscillator frequency divided by 4. The CLKOUT signal may be used to provide a clock for external circuitry, synchronization, calibration, test or other application requirements.

In **INTRCIO** mode, the OSC1 and OSC2 pins are available for general purpose I/O.

3.4.2 HFINTOSC

The High-Frequency Internal Oscillator (HFINTOSC) is a factory calibrated 8 MHz internal clock source. The frequency of the HFINTOSC can be altered approximately $\pm 12\%$ via software using the OSCTUNE register (Register 3-1).

The output of the HFINTOSC connects to a postscaler and multiplexer (see Figure 3-1). One of seven frequencies can be selected via software using the IRCF bits (see **Section 3.4.4 “Frequency Select Bits (IRCF)”**).

The HFINTOSC is enabled by selecting any frequency between 8 MHz and 125 kHz ($IRCF \neq 000$) as the system clock source ($SCS = 1$), or when Two-Speed Start-up is enabled ($IESO = 1$ and $IRCF \neq 000$).

The HF Internal Oscillator (HTS) bit ($OSCCON<2>$) indicates whether the HFINTOSC is stable or not.

3.4.2.1 OSCTUNE Register

The HFINTOSC is factory calibrated but can be adjusted in software by writing to the OSCTUNE register (Register 3-1).

The OSCTUNE register has a tuning range of $\pm 12\%$. The default value of the OSCTUNE register is '0'. The value is a 5-bit two's complement number. Due to process variation, the monotonicity and frequency step cannot be specified.

When the OSCTUNE register is modified, the HFINTOSC frequency will begin shifting to the new frequency. The HFINTOSC clock will stabilize within 1 ms. Code execution continues during this shift. There is no indication that the shift has occurred.

OSCTUNE does not affect the LFINTOSC frequency. Operation of features that depend on the LFINTOSC clock source frequency, such as the Power-up Timer (PWRT), Watchdog Timer (WDT), Fail-Safe Clock Monitor (FSCM) and peripherals, are *not* affected by the change in frequency.

REGISTER 3-1: OSCTUNE – OSCILLATOR TUNING RESISTOR (ADDRESS: 90h)

U-0	U-0	U-0	R/W-0	R/W-0	R/W-0	R/W-0	R/W-0	
—	—	—	TUN4	TUN3	TUN2	TUN1	TUN0	
bit 7								bit 0

bit 7-5 **Unimplemented:** Read as '0'

bit 4-0 **TUN<4:0>:** Frequency Tuning bits

01111 = Maximum frequency

01110 =

•

•

•

00001 =

00000 = Oscillator module is running at the calibrated frequency.

11111 =

•

•

•

10000 = Minimum frequency

Legend:

R = Readable bit

W = Writable bit

U = Unimplemented bit, read as '0'

-n = Value at POR

'1' = Bit is set

'0' = Bit is cleared

x = Bit is unknown

PIC16F684

3.4.3 LFINTOSC

The Low-Frequency Internal Oscillator (LFINTOSC) is an uncalibrated (approximate) 31 kHz internal clock source.

The output of the LFINTOSC connects to a postscaler and multiplexer (see Figure 3-1). 31 kHz can be selected via software using the IRCF bits (see **Section 3.4.4 “Frequency Select Bits (IRCF)”**). The LFINTOSC is also the frequency for the Power-up Timer (PWRT), Watchdog Timer (WDT) and Fail-Safe Clock Monitor (FSCM).

The LFINTOSC is enabled by selecting 31 kHz (IRCF = 000) as the system clock source (SCS = 1), or when any of the following are enabled:

- Two-Speed Start-up (IESO = 1 and IRCF = 000)
- Power-up Timer (PWRT)
- Watchdog Timer (WDT)
- Fail-Safe Clock Monitor (FSCM)

The LF Internal Oscillator (LTS) bit (OSCCON<1>) indicates whether the LFINTOSC is stable or not.

3.4.4 FREQUENCY SELECT BITS (IRCF)

The output of the 8 MHz HFINTOSC and 31 kHz LFINTOSC connects to a postscaler and multiplexer (see Figure 3-1). The Internal Oscillator Frequency select bits, IRCF<2:0> (OSCCON<6:4>), select the frequency output of the internal oscillators. One of eight frequencies can be selected via software:

- 8 MHz
- 4 MHz (Default after Reset)
- 2 MHz
- 1 MHz
- 500 kHz
- 250 kHz
- 125 kHz
- 31 kHz

<p>Note: Following any Reset, the IRCF bits are set to '110' and the frequency selection is set to 4 MHz. The user can modify the IRCF bits to select a different frequency.</p>

3.4.5 HF AND LF INTOSC CLOCK SWITCH TIMING

When switching between the LFINTOSC and the HFINTOSC, the new oscillator may already be shut down to save power. If this is the case, there is a 10 μ s delay after the IRCF bits are modified before the frequency selection takes place. The LTS/HTS bits will reflect the current active status of the LFINTOSC and the HFINTOSC oscillators. The timing of a frequency selection is as follows:

1. IRCF bits are modified.
2. If the new clock is shut down, a 10 μ s clock start-up delay is started.
3. Clock switch circuitry waits for a falling edge of the current clock.
4. CLKOUT is held low and the clock switch circuitry waits for a rising edge in the new clock.
5. CLKOUT is now connected with the new clock. HTS/LTS bits are updated as required.
6. Clock switch is complete.

If the internal oscillator speed selected is between 8 MHz and 125 kHz, there is no start-up delay before the new frequency is selected. This is because the old and the new frequencies are derived from the HFINTOSC via the postscaler and multiplexer.

3.5 Clock Switching

The system clock source can be switched between external and internal clock sources via software using the System Clock Select (SCS) bit.

3.5.1 SYSTEM CLOCK SELECT (SCS) BIT

The System Clock Select (SCS) bit (OSCCON<0>) selects the system clock source that is used for the CPU and peripherals.

- When SCS = 0, the system clock source is determined by configuration of the FOSC<2:0> bits in the Configuration Word register (CONFIG).
- When SCS = 1, the system clock source is chosen by the internal oscillator frequency selected by the IRCF bits. After a Reset, SCS is always cleared.

Note: Any automatic clock switch, which may occur from Two-Speed Start-up or Fail-Safe Clock Monitor, does not update the SCS bit. The user can monitor the OSTs (OSCCON<3>) to determine the current system clock source.

3.5.2 OSCILLATOR START-UP TIME-OUT STATUS BIT

The Oscillator Start-up Time-out Status (OSTS) bit (OSCCON<3>) indicates whether the system clock is running from the external clock source, as defined by the FOSC bits, or from internal clock source. In particular, OSTs indicates that the Oscillator Start-up Timer (OST) has timed out for LP, XT or HS modes.

3.6 Two-Speed Clock Start-up Mode

Two-Speed Start-up mode provides additional power savings by minimizing the latency between external oscillator start-up and code execution. In applications that make heavy use of the Sleep mode, Two-Speed Start-up will remove the external oscillator start-up time from the time spent awake and can reduce the overall power consumption of the device.

This mode allows the application to wake-up from Sleep, perform a few instructions using the INTOSC as the clock source and go back to Sleep without waiting for the primary oscillator to become stable.

Note: Executing a SLEEP instruction will abort the oscillator start-up time and will cause the OSTs bit (OSCCON<3>) to remain clear.

When the PIC16F684 is configured for LP, XT or HS modes, the Oscillator Start-up Timer (OST) is enabled (see **Section 3.3.1 “Oscillator Start-up Timer (OST)”**). The OST timer will suspend program execution until 1024 oscillations are counted. Two-Speed Start-up mode minimizes the delay in code execution by operating from the internal oscillator as the OST is counting. When the OST count reaches 1024 and the OSTs bit (OSCCON<3>) is set, program execution switches to the external oscillator.

3.6.1 TWO-SPEED START-UP MODE CONFIGURATION

Two-Speed Start-up mode is configured by the following settings:

- IESO = 1 (CONFIG<10>) Internal/External Switch Over bit.
- SCS = 0.
- FOSC configured for LP, XT or HS mode.

Two-Speed Start-up mode is entered after:

- Power-on Reset (POR) and, if enabled, after PWRT has expired, or
- Wake-up from Sleep.

If the external clock oscillator is configured to be anything other than LP, XT or HS mode, then Two-Speed Start-up is disabled. This is because the external clock oscillator does not require any stabilization time after POR or an exit from Sleep.

3.6.2 TWO-SPEED START-UP SEQUENCE

1. Wake-up from Power-on Reset or Sleep.
2. Instructions begin execution by the internal oscillator at the frequency set in the IRCF bits (OSCCON<6:4>).
3. OST enabled to count 1024 clock cycles.
4. OST timed out, wait for falling edge of the internal oscillator.
5. OSTs is set.
6. System clock held low until the next falling edge of new clock (LP, XT or HS mode).
7. System clock is switched to external clock source.

PIC16F684

3.6.3 CHECKING EXTERNAL/INTERNAL CLOCK STATUS

Checking the state of the OSTS bit (OSCCON<3>) will confirm if the PIC16F684 is running from the external clock source as defined by the FOSC bits in the Configuration Word register (CONFIG) or the internal oscillator.

FIGURE 3-7: TWO-SPEED START-UP

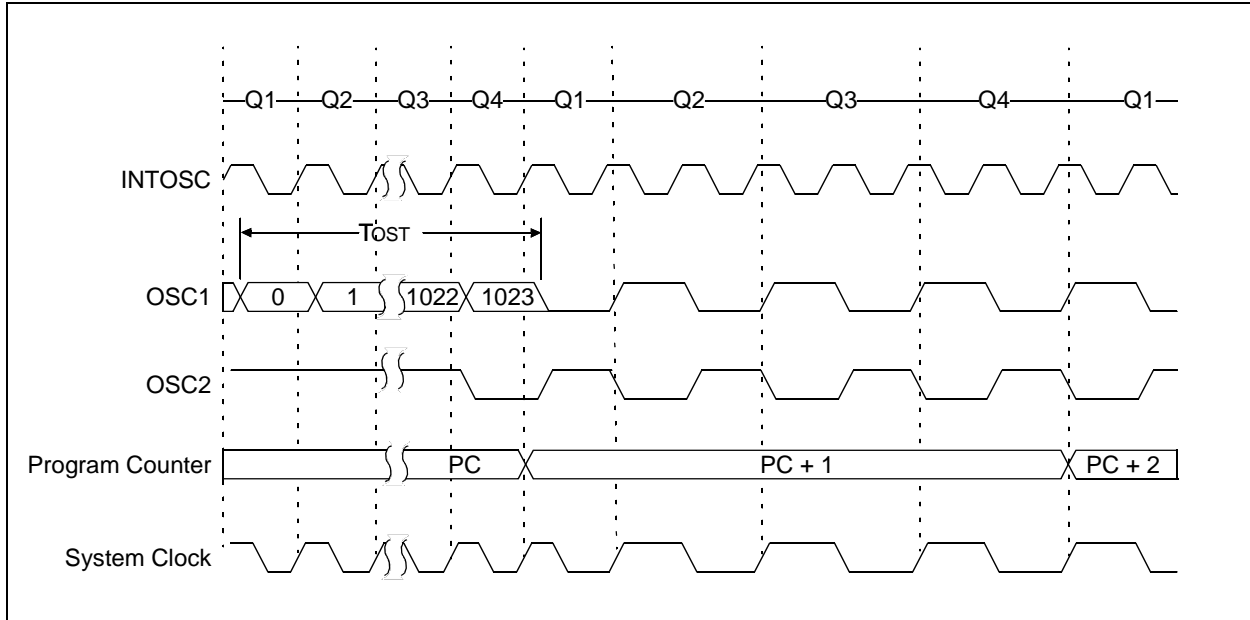

3.7 Fail-Safe Clock Monitor

The Fail-Safe Clock Monitor (FSCM) is designed to allow the device to continue to operate in the event of an oscillator failure. The FSCM can detect oscillator failure at any point after the device has exited a Reset or Sleep condition and the Oscillator Start-up Timer (OST) has expired.

FIGURE 3-8: FSCM BLOCK DIAGRAM

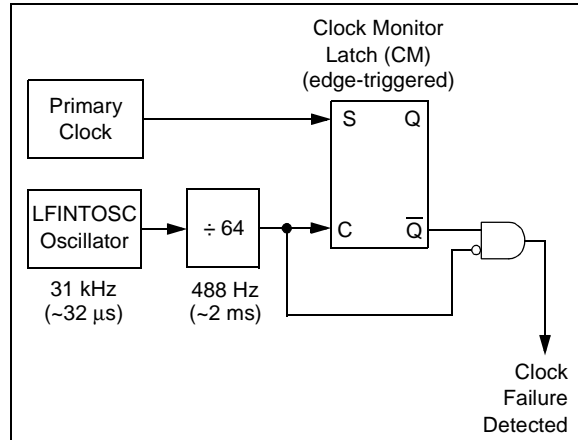

The FSCM function is enabled by setting the FCMEN bit in the Configuration Word register (CONFIG). It is applicable to all external clock options (LP, XT, HS, EC, RC or IO modes).

In the event of an external clock failure, the FSCM will set the OSFIF bit (PIR1<2>) and generate an oscillator fail interrupt if the OSFIE bit (PIE1<2>) is set. The device will then switch the system clock to the internal oscillator. The system clock will continue to come from the internal oscillator unless the external clock recovers and the Fail-Safe condition is exited.

The frequency of the internal oscillator will depend upon the value contained in the IRCF bits (OSCCON<6:4>). Upon entering the Fail-Safe condition, the OSTS bit (OSCCON<3>) is automatically cleared to reflect that the internal oscillator is active and the WDT is cleared. The SCS bit (OSCCON<0>) is not updated. Enabling FSCM does not affect the LTS bit.

The FSCM sample clock is generated by dividing the INTRC clock by 64. This will allow enough time between FSCM sample clocks for a system clock edge to occur. Figure 3-8 shows the FSCM block diagram.

On the rising edge of the sample clock, the monitoring latch (CM = 0) will be cleared. On a falling edge of the primary system clock, the monitoring latch will be set (CM = 1). In the event that a falling edge of the sample clock occurs, and the monitoring latch is not set, a clock failure has been detected. The assigned internal oscillator is enabled when FSCM is enabled, as reflected by the IRCF.

Note: Two-Speed Start-up is automatically enabled when the Fail-Safe Clock Monitor mode is enabled.

Note: Primary clocks with a frequency \leq 488 Hz will be considered failed by the FSCM. A slow starting oscillator can cause an FSCM interrupt.

3.7.1 FAIL-SAFE CONDITION CLEARING

The Fail-Safe condition is cleared after a Reset, the execution of a SLEEP instruction, or a modification of the SCS bit. While in Fail-Safe condition, the PIC16F684 uses the internal oscillator as the system clock source. The IRCF bits (OSCCON<6:4>) can be modified to adjust the internal oscillator frequency without exiting the Fail-Safe condition.

The Fail-Safe condition must be cleared before the OSFIF flag can be cleared.

PIC16F684

FIGURE 3-9: FSCM TIMING DIAGRAM

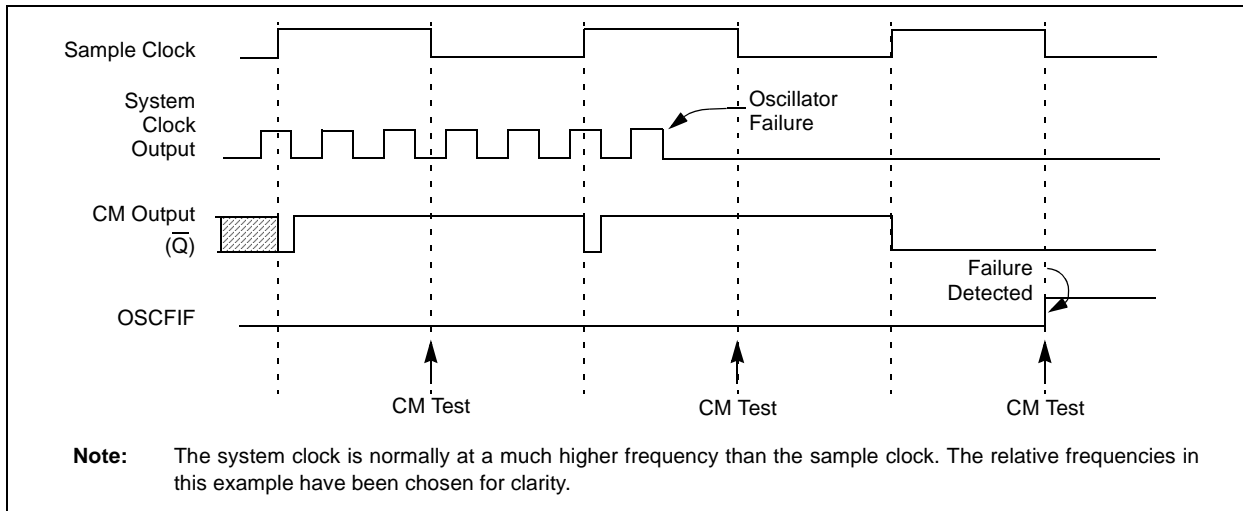

3.7.2 RESET OR WAKE-UP FROM SLEEP

The FSCM is designed to detect oscillator failure at any point after the device has exited a Reset or Sleep condition and the Oscillator Start-up Timer (OST) has expired. If the external clock is EC or RC mode, monitoring will begin immediately following these events.

For LP, XT or HS mode, the external oscillator may require a start-up time considerably longer than the FSCM sample clock time, a false clock failure may be detected (see Figure 3-9). To prevent this, the internal oscillator is automatically configured as the system clock and functions until the external clock is stable (the OST has timed out). This is identical to Two-Speed Start-up mode. Once the external oscillator is stable, the LFINTOSC returns to its role as the FSCM source.

Note: Due to the wide range of oscillator start-up times, the Fail-Safe circuit is not active during oscillator start-up (i.e., after exiting Reset or Sleep). After an appropriate amount of time, the user should check the OSTS bit (OSCCON<3>) to verify the oscillator start-up and system clock switchover has successfully completed.

REGISTER 3-2: OSCCON – OSCILLATOR CONTROL REGISTER (ADDRESS: 8Fh)

U-0	R/W-1	R/W-1	R/W-0	R-1	R-0	R-0	R/W-0
—	IRCF2	IRCF1	IRCF0	OSTS ⁽¹⁾	HTS	LTS	SCS
bit 7							bit 0

- bit 7 **Unimplemented:** Read as '0'
- bit 6-4 **IRCF<2:0>:** Internal Oscillator Frequency Select bits
 000 = 31 kHz
 001 = 125 kHz
 010 = 250 kHz
 011 = 500 kHz
 100 = 1 MHz
 101 = 2 MHz
 110 = 4 MHz
 111 = 8 MHz
- bit 3 **OSTS:** Oscillator Start-up Time-out Status bit
 1 = Device is running from the external system clock defined by FOSC<2:0>
 0 = Device is running from the internal system clock (HFINTOSC or LFINTOSC)
- bit 2 **HTS:** HFINTOSC (High Frequency – 8 MHz to 125 kHz) Status bit
 1 = HFINTOSC is stable
 0 = HFINTOSC is not stable
- bit 1 **LTS:** LFINTOSC (Low Frequency – 31 kHz) Stable bit
 1 = LFINTOSC is stable
 0 = LFINTOSC is not stable
- bit 0 **SCS:** System Clock Select bit
 1 = Internal oscillator is used for system clock
 0 = Clock source defined by FOSC<2:0>

Note 1: Bit resets to '0' with Two-Speed Start-up and LP, XT or HS selected as the Oscillator mode or Fail-Safe mode is enabled.

Legend:

R = Readable bit W = Writable bit U = Unimplemented bit, read as '0'
 -n = Value at POR '1' = Bit is set '0' = Bit is cleared x = Bit is unknown

TABLE 3-2: SUMMARY OF REGISTERS ASSOCIATED WITH CLOCK SOURCES

Address	Name	Bit 7	Bit 6	Bit 5	Bit 4	Bit 3	Bit 2	Bit 1	Bit 0	Value on: POR, BOD	Value on all other Resets
0Ch	PIR1	EEIF	ADIF	CCP1IF	C2IF	C1IF	OSFIF	TMR2IF	TMR1IF	0000 0000	0000 0000
8Ch	PIE1	EEIE	ADIE	CCP1IE	C2IE	C1IE	OSFIE	TMR2IE	TMR1IE	0000 0000	0000 0000
8Fh	OSCCON	—	IRCF2	IRCF1	IRCF0	OSTS	HTS	LTS	SCS	-110 x000	-110 x000
90h	OSCTUNE	—	—	—	TUN4	TUN3	TUN2	TUN1	TUN0	---0 0000	---u uuuu
2007h ⁽¹⁾	CONFIG	CPD	CP	MCLRE	PWRTE	WDTE	FOSC2	FOSC1	FOSC0	—	—

Legend: x = unknown, u = unchanged, — = unimplemented locations read as '0'. Shaded cells are not used by oscillators.

Note 1: See Register 12-1 for operation of all Configuration Word register bits.

PIC16F684

NOTES:

4.0 I/O PORTS

There are as many as twelve general purpose I/O pins available. Depending on which peripherals are enabled, some or all of the pins may not be available as general purpose I/O. In general, when a peripheral is enabled, the associated pin may not be used as a general purpose I/O pin.

Note: Additional information on I/O ports may be found in the "PICmicro® Mid-Range MCU Family Reference Manual" (DS33023).

4.1 PORTA and the TRISA Registers

PORTA is a 6-bit wide, bidirectional port. The corresponding data direction register is TRISA (Register 4-2). Setting a TRISA bit (= 1) will make the corresponding PORTA pin an input (i.e., put the corresponding output driver in a High-impedance mode). Clearing a TRISA bit (= 0) will make the corresponding PORTA pin an output (i.e., put the contents of the output latch on the selected pin). The exception is RA3, which is input only and its TRIS bit will always read as '1'. Example 4-1 shows how to initialize PORTA.

Reading the PORTA register (Register 4-1) reads the status of the pins, whereas writing to it will write to the port latch. All write operations are read-modify-write operations. Therefore, a write to a port implies that the port pins are read, this value is modified and then written to the port data latch. RA3 reads '0' when MCLRE = 1.

The TRISA register controls the direction of the PORTA pins, even when they are being used as analog inputs. The user must ensure the bits in the TRISA register are maintained set when using them as analog inputs. I/O pins configured as analog input always read '0'.

Note: The ANSEL (91h) and CMCON0 (19h) registers must be initialized to configure an analog channel as a digital input. Pins configured as analog inputs will read '0'.

EXAMPLE 4-1: INITIALIZING PORTA

```
BCF    STATUS,RP0    ;Bank 0
CLRF   PORTA        ;Init PORTA
MOVLW  07h          ;Set RA<2:0> to
MOVWF  CMCON0       ;digital I/O
BSF    STATUS,RP0    ;Bank 1
CLRF   ANSEL        ;digital I/O
MOVLW  0Ch          ;Set RA<3:2> as inputs
MOVWF  TRISA        ;and set RA<5:4,1:0>
                          ;as outputs
BCF    STATUS,RP0    ;Bank 0
```

4.2 Additional Pin Functions

Every PORTA pin on the PIC16F684 has an interrupt-on-change option and a weak pull-up option. RA0 has an Ultra Low-Power Wake-up option. The next three sections describe these functions.

4.2.1 WEAK PULL-UPS

Each of the PORTA pins, except RA3, has an individually configurable internal weak pull-up. Control bits WPUAx enable or disable each pull-up. Refer to Register 4-3. Each weak pull-up is automatically turned off when the port pin is configured as an output. The pull-ups are disabled on a Power-on Reset by the RPU bit (OPTION_REG<7>). A weak pull-up is automatically enabled for RA3 when configured as MCLR and disabled when RA3 is an I/O. There is no software control of the MCLR pull-up.

REGISTER 4-1: PORTA – PORTA REGISTER (ADDRESS: 05h)

U-0	U-0	R/W-x	R/W-x	R/W-x	R/W-x	R/W-0	R/W-0	
—	—	RA5	RA4	RA3	RA2	RA1	RA0	
bit 7								bit 0

bit 7-6: **Unimplemented:** Read as '0'

bit 5-0: **RA<5:0>:** PORTA I/O Pin bit

1 = Port pin is > VIH
0 = Port pin is < VIL

Legend:

R = Readable bit W = Writable bit U = Unimplemented bit, read as '0'
-n = Value at POR '1' = Bit is set '0' = Bit is cleared x = Bit is unknown

PIC16F684

REGISTER 4-2: TRISA – PORTA TRI-STATE REGISTER (ADDRESS: 85h)

U-0	U-0	R/W-1	R/W-1	R-1	R/W-1	R/W-1	R/W-1	
—	—	TRISA5	TRISA4	TRISA3	TRISA2	TRISA1	TRISA0	
bit 7								bit 0

- bit 7-6: **Unimplemented:** Read as '0'
 bit 5-0: **TRISA<5:0>:** PORTA Tri-State Control bit
 1 = PORTA pin configured as an input (tri-stated)
 0 = PORTA pin configured as an output

- Note 1:** TRISA<3> always reads '1'.
2: TRISA<5:4> always reads '1' in XT, HS and LP OSC modes.

Legend:			
R = Readable bit	W = Writable bit	U = Unimplemented bit, read as '0'	
-n = Value at POR	'1' = Bit is set	'0' = Bit is cleared	x = Bit is unknown

REGISTER 4-3: WPUA – WEAK PULL-UP REGISTER (ADDRESS: 95h)

U-0	U-0	R/W-1	R/W-1	U-0	R/W-1	R/W-1	R/W-1	
—	—	WPUA5	WPUA4	—	WPUA2	WPUA1	WPUA0	
bit 7								bit 0

- bit 7-6: **Unimplemented:** Read as '0'
 bit 5-4: **WPUA<5:4>:** Weak Pull-up Register bit
 1 = Pull-up enabled
 0 = Pull-up disabled
 bit 3: **Unimplemented:** Read as '0'
 bit 2-0: **WPUA<2:0>:** Weak Pull-up Register bit
 1 = Pull-up enabled
 0 = Pull-up disabled

- Note 1:** Global $\overline{\text{RAPU}}$ must be enabled for individual pull-ups to be enabled.
2: The weak pull-up device is automatically disabled if the pin is in Output mode (TRISA = 0).
3: The RA3 pull-up is enabled when configured as $\overline{\text{MCLR}}$ and disabled as an I/O in the configuration word.
4: WPUA<5:4> always reads '1' in XT, HS and LP OSC modes.

Legend:			
R = Readable bit	W = Writable bit	U = Unimplemented bit, read as '0'	
-n = Value at POR	'1' = Bit is set	'0' = Bit is cleared	x = Bit is unknown

4.2.2 INTERRUPT-ON-CHANGE

Each of the PORTA pins is individually configurable as an interrupt-on-change pin. Control bits IOCAx enable or disable the interrupt function for each pin. Refer to Register 4-4. The interrupt-on-change is disabled on a Power-on Reset.

For enabled interrupt-on-change pins, the values are compared with the old value latched on the last read of PORTA. The 'mismatch' outputs of the last read are OR'd together to set the PORTA Change Interrupt Flag bit (RAIF) in the INTCON register (Register 2-3).

This interrupt can wake the device from Sleep. The user, in the Interrupt Service Routine, clears the interrupt by:

- a) Any read or write of PORTA. This will end the mismatch condition, then,
- b) Clear the flag bit RAIF.

A mismatch condition will continue to set flag bit RAIF. Reading PORTA will end the mismatch condition and allow flag bit RAIF to be cleared. The latch holding the last read value is not affected by a MCLR nor BOD Reset. After these resets, the RAIF flag will continue to be set if a mismatch is present.

Note: If a change on the I/O pin should occur when the read operation is being executed (start of the Q2 cycle), then the RAIF interrupt flag may not get set.

REGISTER 4-4: IOCA – INTERRUPT-ON-CHANGE PORTA REGISTER (ADDRESS: 96h)

U-0	U-0	R/W-0	R/W-0	R/W-0	R/W-0	R/W-0	R/W-0	
—	—	IOCA5	IOCA4	IOCA3	IOCA2	IOCA1	IOCA0	
bit 7								bit 0

bit 7-6 **Unimplemented:** Read as '0'

bit 5-0 **IOCA<5:0>:** Interrupt-on-change PORTA Control bit
 1 = Interrupt-on-change enabled
 0 = Interrupt-on-change disabled

Note 1: Global Interrupt Enable (GIE) must be enabled for individual interrupts to be recognized.

2: IOCA<5:4> always reads '1' in XT, HS and LP OSC modes.

Legend:

R = Readable bit W = Writable bit U = Unimplemented bit, read as '0'
 -n = Value at POR '1' = Bit is set '0' = Bit is cleared x = Bit is unknown

PIC16F684

4.2.3 ULTRA LOW-POWER WAKE-UP

The Ultra Low-power Wake-up (ULPWU) on RA0 allows a slow falling voltage to generate an interrupt-on-change on RA0 without excess current consumption. The mode is selected by setting the ULPWUE bit (PCON<5>). This enables a small current sink which can be used to discharge a capacitor on RA0.

To use this feature, the RA0 pin is configured to output '1' to charge the capacitor, interrupt-on-change for RA0 is enabled, and RA0 is configured as an input. The ULPWUE bit is set to begin the discharge and a SLEEP instruction is performed. When the voltage on RA0 drops below VIL, an interrupt will be generated which will cause the device to wake-up. Depending on the state of the GIE bit (INTCON<7>), the device will either jump to the interrupt vector (0004h) or execute the next instruction when the interrupt event occurs. See **Section 4.2.2 "Interrupt-on-change"** and **Section 12.4.3 "PORTA Interrupt"** for more information.

This feature provides a low-power technique for periodically waking up the device from Sleep. The time-out is dependent on the discharge time of the RC circuit on RA0. See Example 4-2 for initializing the Ultra Low-Power Wake-up module.

The series resistor provides overcurrent protection for the RA0 pin and can allow for software calibration of the time-out (see Figure 4-1). A timer can be used to measure the charge time and discharge time of the capacitor. The charge time can then be adjusted to provide the desired interrupt delay. This technique will compensate for the affects of temperature, voltage and component accuracy. The Ultra Low-power Wake-up peripheral can also be configured as a simple Programmable Low Voltage Detect or temperature sensor.

Note: For more information, refer to AN879, "Using the Microchip Ultra Low-Power Wake-up Module" Application Note (DS00879).

EXAMPLE 4-2: ULTRA LOW-POWER WAKE-UP INITIALIZATION

```
BCF    STATUS,RP0    ;Bank 0
BSF    PORTA,0       ;Set RA0 data latch
MOVLW  H'7'         ;Turn off
MOVWF  CMCON0       ;comparators
BSF    STATUS,RP0    ;Bank 1
BCF    ANSEL,0       ;RA0 to digital I/O
BCF    TRISA,0       ;Output high to
CALL   CapDelay     ; charge capacitor
BSF    PCON,ULPWUE  ;Enable ULP Wake-up
BSF    IOCA,0        ;Select RA0 IOC
BSF    TRISA,0       ;RA0 to input
MOVLW  B'10001000'  ;Enable interrupt
MOVWF  INTCON        ; and clear flag
SLEEP                               ;Wait for IOC
```

FIGURE 4-1: BLOCK DIAGRAM OF RAO

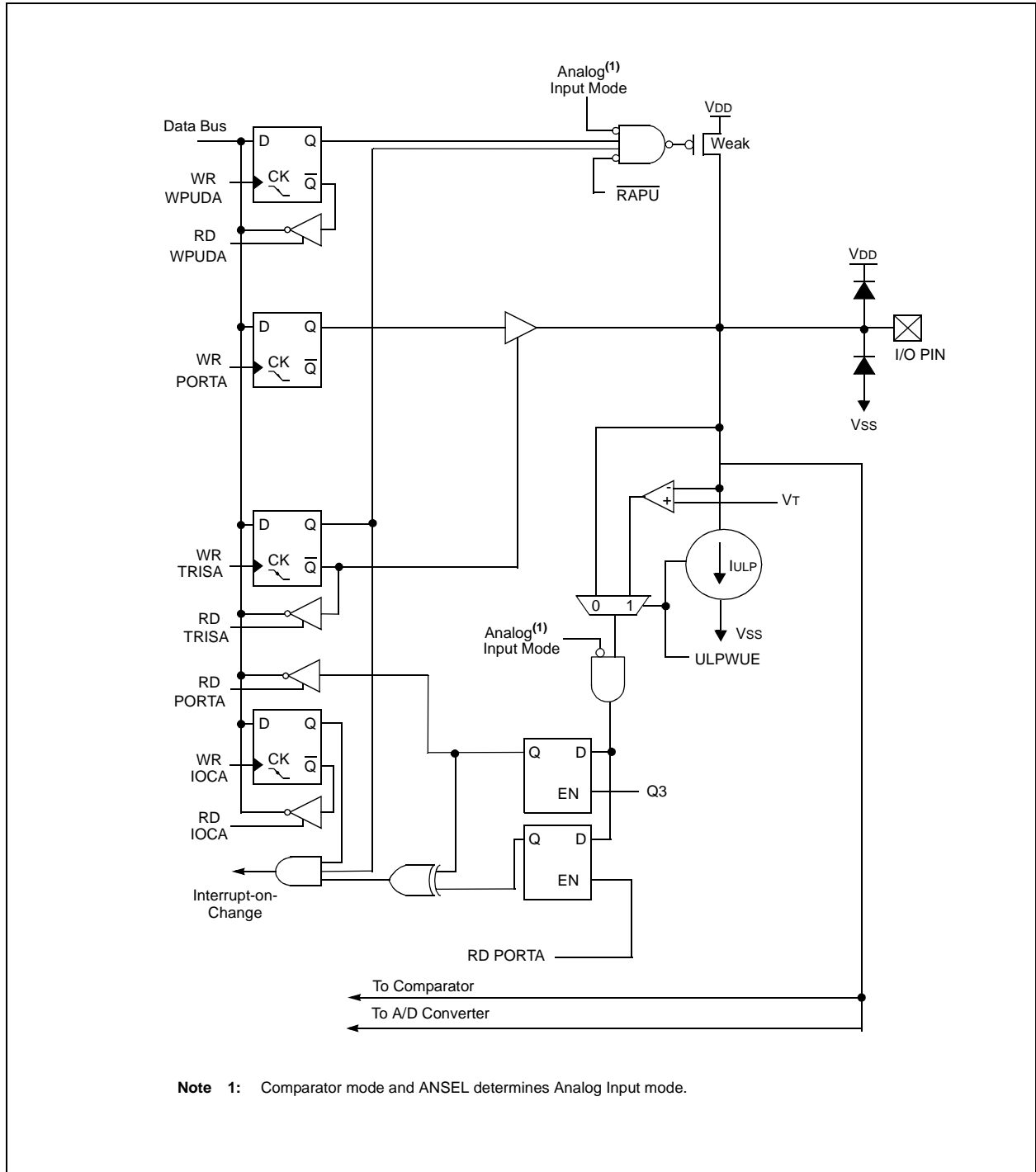

PIC16F684

4.2.4 PIN DESCRIPTIONS AND DIAGRAMS

Each PORTA pin is multiplexed with other functions. The pins and their combined functions are briefly described here. For specific information about individual functions such as the comparator or the A/D, refer to the appropriate section in this data sheet.

4.2.4.1 RA0/AN0/C1IN+/ICSPDAT/ULPWU

Figure 4-2 shows the diagram for this pin. The RA0 pin is configurable to function as one of the following:

- a general purpose I/O
- an analog input for the A/D
- an analog input to the comparator
- In-Circuit Serial Programming data
- an analog input for the Ultra Low-power Wake-up

4.2.4.2 RA1/AN1/C1IN-/VREF/ICSPCLK

Figure 4-2 shows the diagram for this pin. The RA1 pin is configurable to function as one of the following:

- a general purpose I/O
- an analog input for the A/D
- an analog input to the comparator
- a voltage reference input for the A/D
- In-Circuit Serial Programming clock

FIGURE 4-2: BLOCK DIAGRAM OF RA1

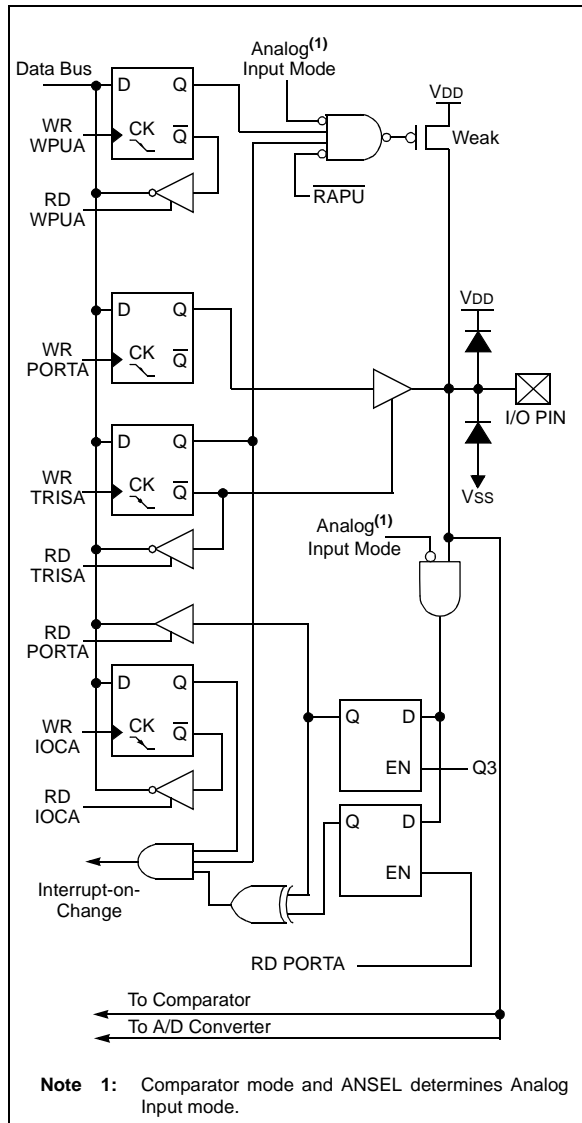

4.2.4.3 RA2/AN2/T0CKI/INT/C1OUT

Figure 4-3 shows the diagram for this pin. The RA2 pin is configurable to function as one of the following:

- a general purpose I/O
- an analog input for the A/D
- the clock input for TMR0
- an external edge triggered interrupt
- a digital output from comparator 1

FIGURE 4-3: BLOCK DIAGRAM OF RA2

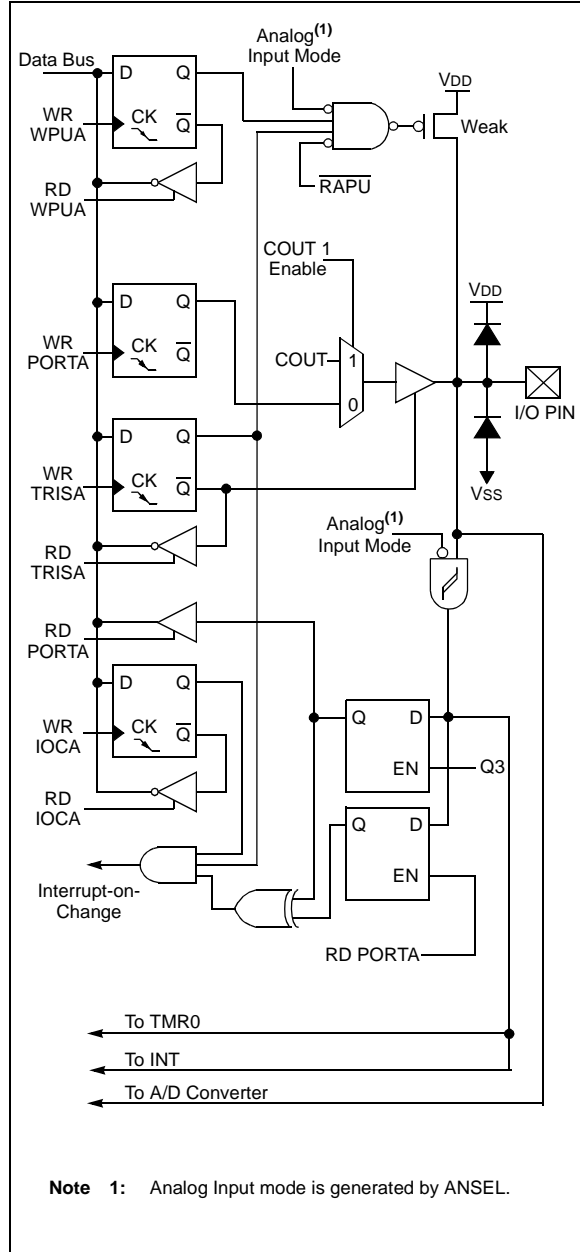

4.2.4.4 RA3/MCLR/VPP

Figure 4-4 shows the diagram for this pin. The RA3 pin is configurable to function as one of the following:

- a general purpose input
- as Master Clear Reset with weak pull-up

FIGURE 4-4: BLOCK DIAGRAM OF RA3

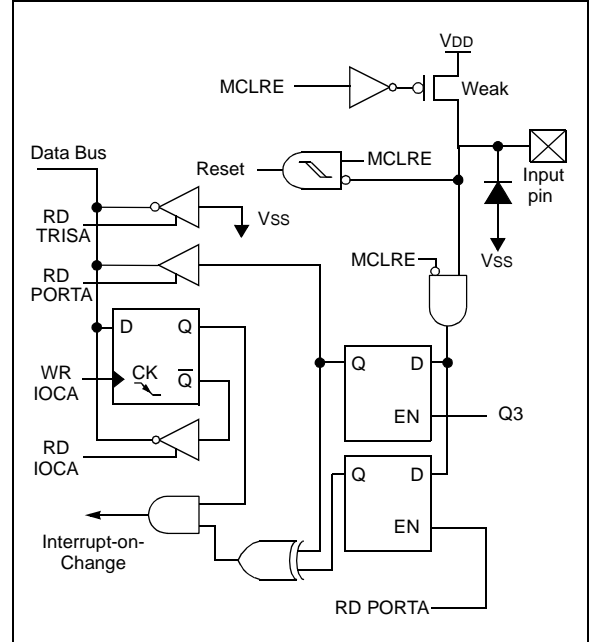

PIC16F684

4.2.4.5 RA4/AN3/T1G/OSC2/CLKOUT

Figure 4-5 shows the diagram for this pin. The RA4 pin is configurable to function as one of the following:

- a general purpose I/O
- an analog input for the A/D
- a TMR1 gate input
- a crystal/resonator connection
- a clock output

FIGURE 4-5: BLOCK DIAGRAM OF RA4

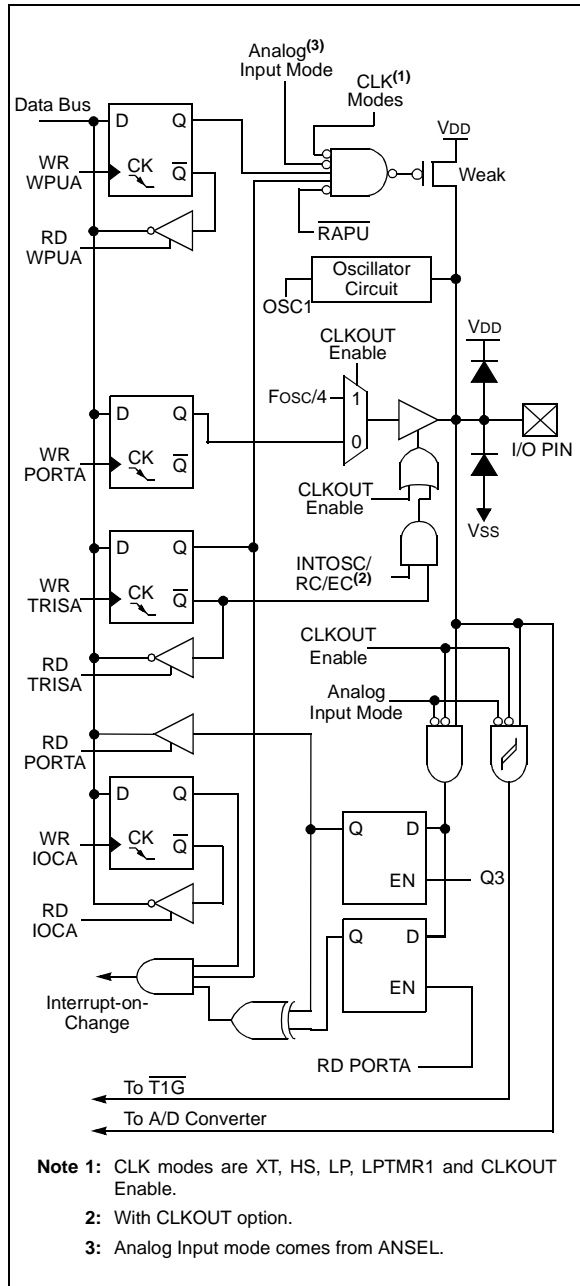

4.2.4.6 RA5/T1CKI/OSC1/CLKIN

Figure 4-6 shows the diagram for this pin. The RA5 pin is configurable to function as one of the following:

- a general purpose I/O
- a TMR1 clock input
- a crystal/resonator connection
- a clock input

FIGURE 4-6: BLOCK DIAGRAM OF RA5

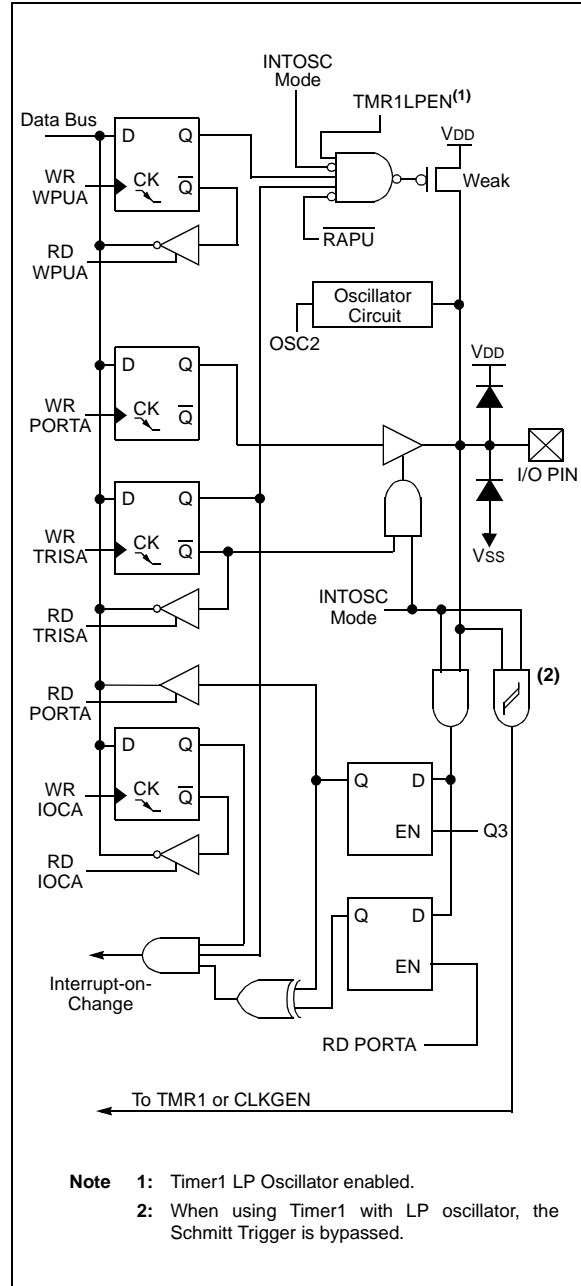

TABLE 4-1: SUMMARY OF REGISTERS ASSOCIATED WITH PORTA

Addr	Name	Bit 7	Bit 6	Bit 5	Bit 4	Bit 3	Bit 2	Bit 1	Bit 0	Value on: POR, BOD	Value on all other Resets
05h	PORTA	—	—	RA5	RA4	RA3	RA2	RA1	RA0	--xx xx00	--uu uu00
0Bh/8Bh	INTCON	GIE	PEIE	T0IE	INTE	RAIE	T0IF	INTF	RAIF	0000 0000	0000 0000
19h	CMCON0	C2OUT	C1OUT	C2INV	C1INV	CIS	CM2	CM1	CM0	0000 0000	0000 0000
81h	OPTION_REG	$\overline{\text{RAPU}}$	INTEDG	T0CS	T0SE	PSA	PS2	PS1	PS0	1111 1111	1111 1111
85h	TRISA	—	—	TRISA5	TRISA4	TRISA3	TRISA2	TRISA1	TRISA0	--11 1111	--11 1111
91h	ANSEL	ANS7	ANS6	ANS5	ANS4	ANS3	ANS2	ANS1	ANS0	1111 1111	1111 1111
95h	WPUA	—	—	WPUA5	WPUA4	—	WPUA2	WPUA1	WPUA0	--11 -111	--11 -111
96h	IOCA	—	—	IOCA5	IOCA4	IOCA3	IOCA2	IOCA1	IOCA0	--00 0000	--00 0000

Legend: x = unknown, u = unchanged, — = unimplemented locations read as '0'. Shaded cells are not used by PORTA.

PIC16F684

4.3 PORTC

PORTC is a general purpose I/O port consisting of 6 bidirectional pins. The pins can be configured for either digital I/O or analog input to A/D converter or comparator. For specific information about individual functions such as the Enhanced CCP or the A/D, refer to the appropriate section in this data sheet.

Note: The ANSEL (91h) and CMCON0 (19h) registers must be initialized to configure an analog channel as a digital input. Pins configured as analog inputs will read '0'.

EXAMPLE 4-3: INITIALIZING PORTC

```
BCF STATUS,RP0 ;Bank 0
CLRF PORTC ;Init PORTC
MOVLW 07h ;Set RC<4,1:0> to
MOVWF CMCON0 ;digital I/O
BSF STATUS,RP0 ;Bank 1
CLRF ANSEL ;digital I/O
MOVLW 0Ch ;Set RC<3:2> as inputs
MOVWF TRISC ;and set RC<5:4,1:0>
;as outputs
BCF STATUS,RP0 ;Bank 0
```

4.3.1 RC0/AN4/C2IN+

The RC0 is configurable to function as one of the following:

- a general purpose I/O
- an analog input for the A/D Converter
- an analog input to the comparator

4.3.2 RC1/AN5/C2IN-

The RC1 is configurable to function as one of the following:

- a general purpose I/O
- an analog input for the A/D Converter
- an analog input to the comparator

FIGURE 4-7: BLOCK DIAGRAM OF RC0 AND RC1

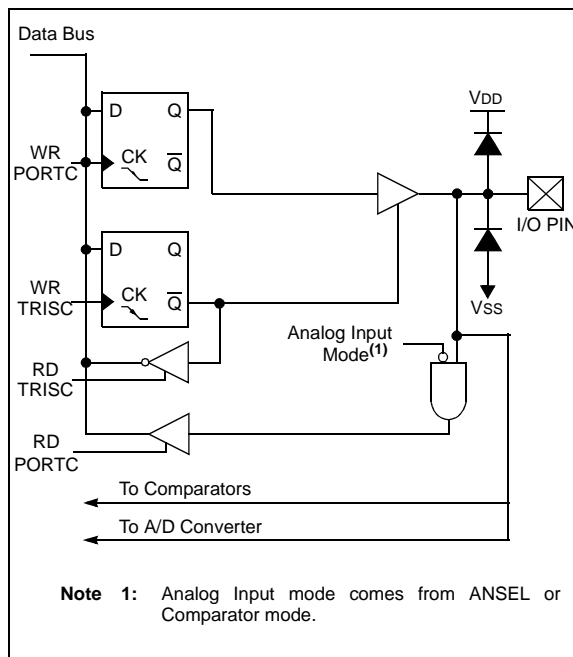

4.3.3 RC2/AN6/P1D

The RC2 is configurable to function as one of the following:

- a general purpose I/O
- an analog input for the A/D Converter
- a digital output from the Enhanced CCP

4.3.4 RC3/AN7/P1C

The RC3 is configurable to function as one of the following:

- a general purpose I/O
- an analog input for the A/D Converter
- a digital output from the Enhanced CCP

FIGURE 4-8: BLOCK DIAGRAM OF RC2 AND RC3

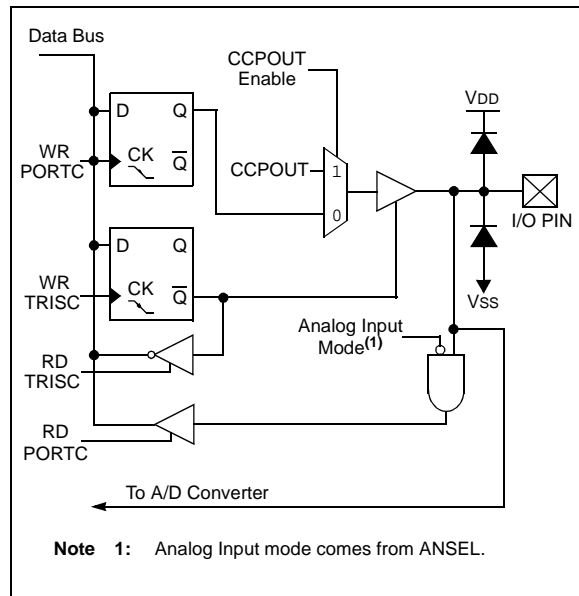

4.3.5 RC4/C2OUT/P1B

The RC4 is configurable to function as one of the following:

- a general purpose I/O
- a digital output from the comparator
- a digital output from the Enhanced CCP

Note: Enabling both C2OUT and P1B will cause a conflict on RC4 and create unpredictable results. Therefore, if C2OUT is enabled, the ECCP can not be used in Half-bridge or Full-bridge mode and vice-versa.

FIGURE 4-9: BLOCK DIAGRAM OF RC4

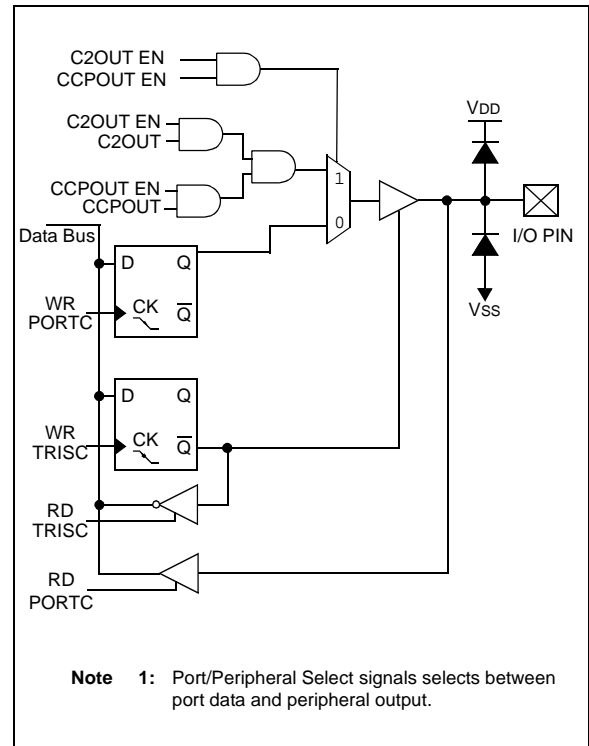

PIC16F684

4.3.6 RC5/CCP1/P1A

The RC5 is configurable to function as one of the following:

- a general purpose I/O
- a digital input/output for the Enhanced CCP

FIGURE 4-10: BLOCK DIAGRAM OF RC5 PIN

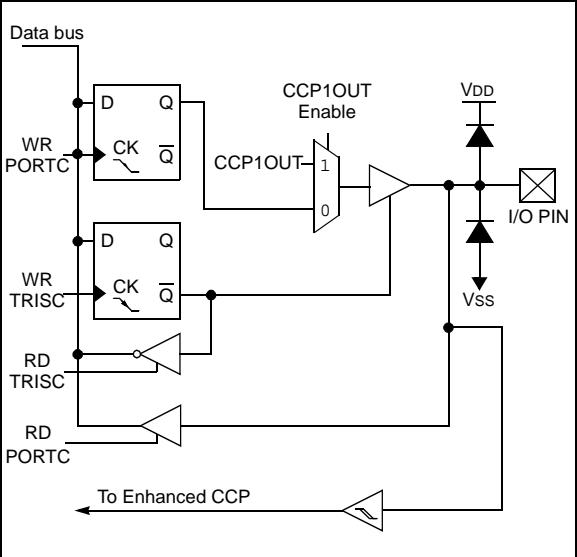

REGISTER 4-5: PORTC – PORTC REGISTER (ADDRESS: 07h)

U-0	U-0	R/W-x	R/W-x	R/W-x	R/W-x	R/W-0	R/W-0	
—	—	RC5	RC4	RC3	RC2	RC1	RC0	
bit 7								bit 0

bit 7-6: **Unimplemented:** Read as '0'

bit 5-0: **RC<5:0>:** PORTC General Purpose I/O Pin bits

1 = Port pin is >VIH

0 = Port pin is <VIL

Legend:

R = Readable bit W = Writable bit U = Unimplemented bit, read as '0'
 -n = Value at POR '1' = Bit is set '0' = Bit is cleared x = Bit is unknown

REGISTER 4-6: TRISC – PORTC TRI-STATE REGISTER (ADDRESS: 87h)

U-0	U-0	R/W-1	R/W-1	R/W-1	R/W-1	R/W-1	R/W-1	
—	—	TRISC5	TRISC4	TRISC3	TRISC2	TRISC1	TRISC0	
bit 7								bit 0

bit 7-6: **Unimplemented:** Read as '0'

bit 5-0: **TRISC<5:0>:** PORTC Tri-State Control bit

1 = PORTC pin configured as an input (tri-stated)

0 = PORTC pin configured as an output

Legend:

R = Readable bit W = Writable bit U = Unimplemented bit, read as '0'
 -n = Value at POR '1' = Bit is set '0' = Bit is cleared x = Bit is unknown

TABLE 4-2: SUMMARY OF REGISTERS ASSOCIATED WITH PORTC

Address	Name	Bit 7	Bit 6	Bit 5	Bit 4	Bit 3	Bit 2	Bit 1	Bit 0	Value on: POR, BOD	Value on all other Resets
07h	PORTC	—	—	RC5	RC4	RC3	RC2	RC1	RC0	--xx xx00	--uu uu00
19h	CMCON0	C2OUT	C1OUT	C2INV	C1INV	CIS	CM2	CM1	CM0	0000 0000	0000 0000
87h	TRISC	—	—	TRISC5	TRISC4	TRISC3	TRISC2	TRISC1	TRISC0	--11 1111	--11 1111
91h	ANSEL	ANS7	ANS6	ANS5	ANS4	ANS3	ANS2	ANS1	ANS0	1111 1111	1111 1111

Legend: x = unknown, u = unchanged, — = unimplemented locations read as '0'. Shaded cells are not used by PORTC.

PIC16F684

NOTES:

5.0 TIMER0 MODULE

The Timer0 module timer/counter has the following features:

- 8-bit timer/counter
- Readable and writable
- 8-bit software programmable prescaler
- Internal or external clock select
- Interrupt on overflow from FFh to 00h
- Edge select for external clock

Figure 5-1 is a block diagram of the Timer0 module and the prescaler shared with the WDT.

Note: Additional information on the Timer0 module is available in the "PICmicro® Mid-Range MCU Family Reference Manual" (DS33023).

5.1 Timer0 Operation

Timer mode is selected by clearing the T0CS bit (OPTION_REG<5>). In Timer mode, the Timer0 module will increment every instruction cycle (without prescaler). If TMR0 is written, the increment is inhibited for the following two instruction cycles. The user can work around this by writing an adjusted value to the TMR0 register.

Counter mode is selected by setting the T0CS bit (OPTION_REG<5>). In this mode, the Timer0 module will increment either on every rising or falling edge of pin RA2/T0CKI. The incrementing edge is determined by the source edge (T0SE) control bit (OPTION_REG<4>). Clearing the T0SE bit selects the rising edge.

Note: Counter mode has specific external clock requirements. Additional information on these requirements is available in the "PICmicro® Mid-Range MCU Family Reference Manual" (DS33023).

5.2 Timer0 Interrupt

A Timer0 interrupt is generated when the TMR0 register timer/counter overflows from FFh to 00h. This overflow sets the T0IF bit (INTCON<2>). The interrupt can be masked by clearing the T0IE bit (INTCON<5>). The T0IF bit must be cleared in software by the Timer0 module Interrupt Service Routine before re-enabling this interrupt. The Timer0 interrupt cannot wake the processor from Sleep since the timer is shut off during Sleep.

FIGURE 5-1: BLOCK DIAGRAM OF THE TIMER0/WDT PRESCALER

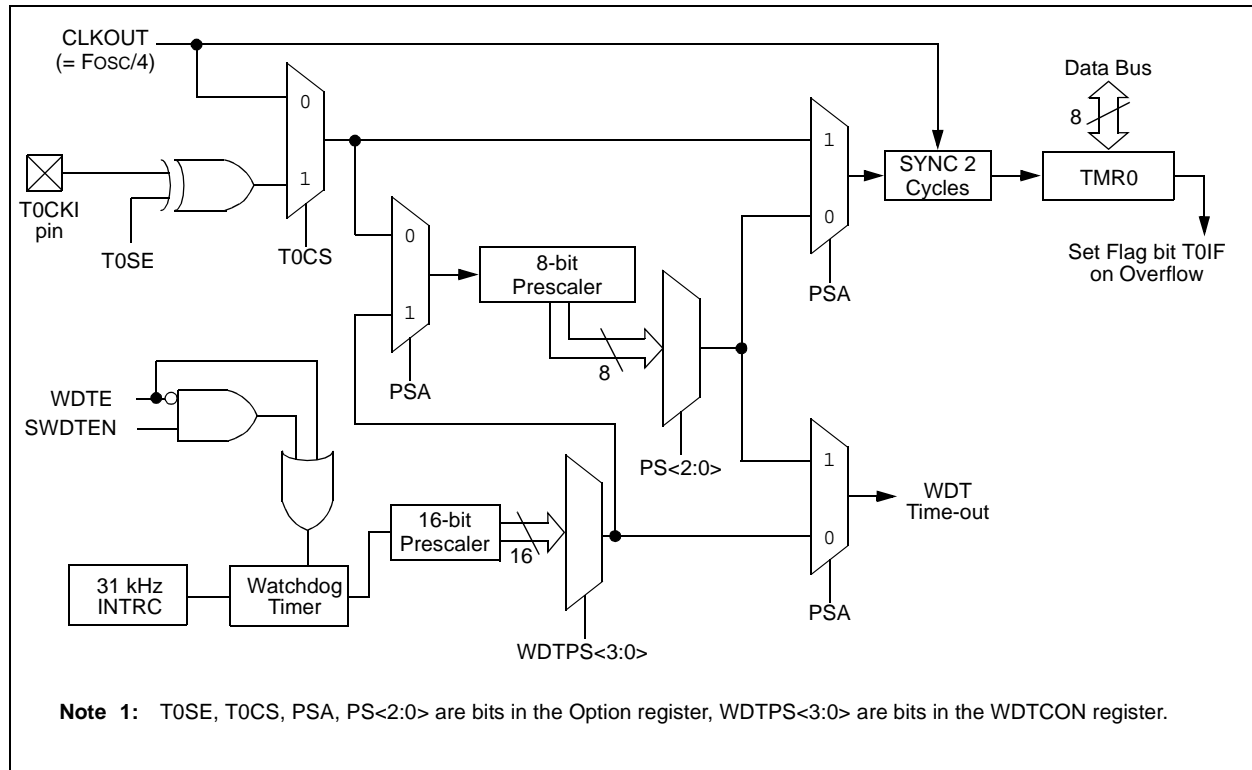

PIC16F684

5.3 Using Timer0 with an External Clock

When no prescaler is used, the external clock input is the same as the prescaler output. The synchronization of T0CKI, with the internal phase clocks, is accomplished by sampling the prescaler output on the Q2 and Q4 cycles of the internal phase clocks. Therefore, it is necessary for T0CKI to be high for at least 2 TOSC (and a small RC delay of 20 ns) and low for at least 2 TOSC (and a small RC delay of 20 ns). Refer to the electrical specification of the desired device.

Note: The ANSEL (91h) and CMCON0 (19h) registers must be initialized to configure an analog channel as a digital input. Pins configured as analog inputs will read '0'.

REGISTER 5-1: OPTION_REG – OPTION REGISTER (ADDRESS: 81h)

R/W-1	R/W-1	R/W-1	R/W-1	R/W-1	R/W-1	R/W-1	R/W-1
$\overline{\text{RAPU}}$	INTEDG	T0CS	T0SE	PSA	PS2	PS1	PS0
bit 7							bit 0

- bit 7 **$\overline{\text{RAPU}}$** : PORTA Pull-up Enable bit
1 = PORTA pull-ups are disabled
0 = PORTA pull-ups are enabled by individual port latch values in WPUA register
- bit 6 **INTEDG**: Interrupt Edge Select bit
1 = Interrupt on rising edge of RA2/INT pin
0 = Interrupt on falling edge of RA2/INT pin
- bit 5 **T0CS**: TMR0 Clock Source Select bit
1 = Transition on RA2/T0CKI pin
0 = Internal instruction cycle clock (CLKOUT)
- bit 4 **T0SE**: TMR0 Source Edge Select bit
1 = Increment on high-to-low transition on RA2/T0CKI pin
0 = Increment on low-to-high transition on RA2/T0CKI pin
- bit 3 **PSA**: Prescaler Assignment bit
1 = Prescaler is assigned to the WDT
0 = Prescaler is assigned to the Timer0 module
- bit 2-0 **PS<2:0>**: Prescaler Rate Select bits

Bit Value	TMR0 Rate	WDT Rate ⁽¹⁾
000	1 : 2	1 : 1
001	1 : 4	1 : 2
010	1 : 8	1 : 4
011	1 : 16	1 : 8
100	1 : 32	1 : 16
101	1 : 64	1 : 32
110	1 : 128	1 : 64
111	1 : 256	1 : 128

Note 1: A dedicated 16-bit WDT postscaler is available for the PIC16F684. See Section 12.6 “Watchdog Timer (WDT)” for more information.

Legend:

R = Readable bit	W = Writable bit	U = Unimplemented bit, read as '0'
-n = Value at POR	'1' = Bit is set	'0' = Bit is cleared x = Bit is unknown

5.4 Prescaler

An 8-bit counter is available as a prescaler for the Timer0 module, or as a postscaler for the Watchdog Timer. For simplicity, this counter will be referred to as “prescaler” throughout this data sheet. The prescaler assignment is controlled in software by the control bit PSA (OPTION_REG<3>). Clearing the PSA bit will assign the prescaler to Timer0. Prescale values are selectable via the PS<2:0> bits (OPTION_REG<2:0>).

The prescaler is not readable or writable. When assigned to the Timer0 module, all instructions writing to the TMR0 register (e.g., CLRF 1, MOVWF 1, BSF 1, x...etc.) will clear the prescaler. When assigned to WDT, a CLRWDT instruction will clear the prescaler along with the Watchdog Timer.

5.4.1 SWITCHING PRESCALER ASSIGNMENT

The prescaler assignment is fully under software control (i.e., it can be changed “on the fly” during program execution). To avoid an unintended device Reset, the following instruction sequence (Example 5-1 and Example 5-2) must be executed when changing the prescaler assignment from Timer0 to WDT.

EXAMPLE 5-1: CHANGING PRESCALER (TIMER0→WDT)

```
BCF    STATUS,RP0    ;Bank 0
CLRWDT                ;Clear WDT
CLRF   TMR0          ;Clear TMR0 and
                    ; prescaler
BSF    STATUS,RP0    ;Bank 1

MOVLW  b'00101111'   ;Required if desired
MOVWF  OPTION_REG    ; PS2:PS0 is
CLRWDT                ; 000 or 001
                    ;
MOVLW  b'00101xxx'   ;Set postscaler to
MOVWF  OPTION_REG    ; desired WDT rate
BCF    STATUS,RP0    ;Bank 0
```

To change prescaler from the WDT to the TMR0 module, use the sequence shown in Example 5-2. This precaution must be taken even if the WDT is disabled.

EXAMPLE 5-2: CHANGING PRESCALER (WDT→TIMER0)

```
CLRWDT                ;Clear WDT and
                    ; prescaler
BSF    STATUS,RP0    ;Bank 1

MOVLW  b'xxxx0xxx'   ;Select TMR0,
                    ; prescale, and
                    ; clock source
MOVWF  OPTION_REG    ;
BCF    STATUS,RP0    ;Bank 0
```

TABLE 5-1: REGISTERS ASSOCIATED WITH TIMER0

Address	Name	Bit 7	Bit 6	Bit 5	Bit 4	Bit 3	Bit 2	Bit 1	Bit 0	Value on POR, BOD	Value on all other Resets
01h	TMR0	Timer0 Module register								xxxx xxxx	uuuu uuuu
0Bh/8Bh	INTCON	GIE	PEIE	TOIE	INTE	RAIE	T0IF	INTF	RAIF	0000 0000	0000 0000
81h	OPTION_REG	RAPU	INTEDG	TOCS	T0SE	PSA	PS2	PS1	PS0	1111 1111	1111 1111
85h	TRISA	—	—	TRISA5	TRISA4	TRISA3	TRISA2	TRISA1	TRISA0	--11 1111	--11 1111

Legend: — = Unimplemented locations, read as '0', u = unchanged, x = unknown. Shaded cells are not used by the Timer0 module.

PIC16F684

NOTES:

6.0 TIMER1 MODULE WITH GATE CONTROL

The PIC16F684 has a 16-bit timer. Figure 6-1 shows the basic block diagram of the Timer1 module. Timer1 has the following features:

- 16-bit timer/counter (TMR1H:TMR1L)
- Readable and writable
- Internal or external clock selection
- Synchronous or asynchronous operation
- Interrupt on overflow from FFFFh to 0000h
- Wake-up upon overflow (Asynchronous mode)
- Optional external enable input
 - Selectable gate source: $\overline{T1G}$ or C2 output (T1GSS)
 - Selectable gate polarity (T1GINV)
- Optional LP oscillator

The Timer1 Control register (T1CON), shown in Register 6-1, is used to enable/disable Timer1 and select the various features of the Timer1 module.

Note: Additional information on timer modules is available in the "PICmicro® Mid-Range MCU Family Reference Manual" (DS33023).

FIGURE 6-1: TIMER1 ON THE PIC16F684 BLOCK DIAGRAM

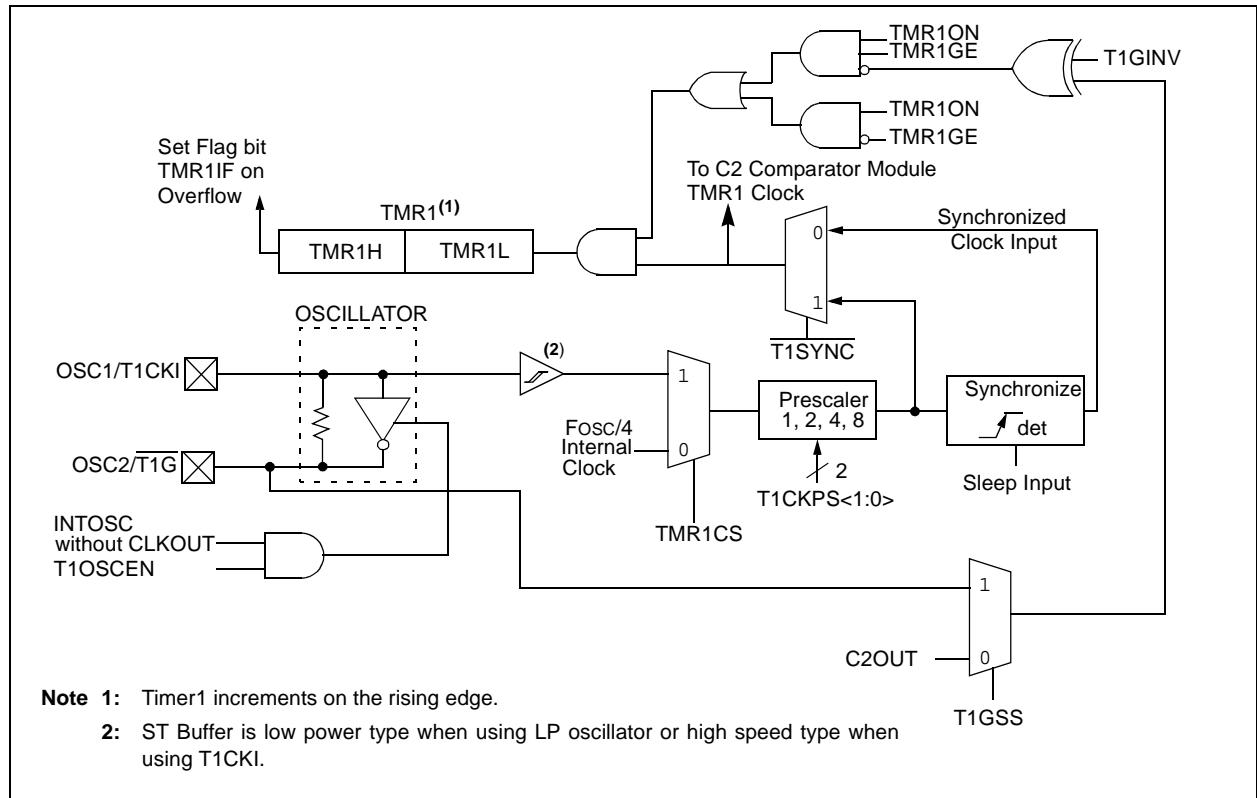

PIC16F684

6.1 Timer1 Modes of Operation

Timer1 can operate in one of three modes:

- 16-bit Timer with prescaler
- 16-bit Synchronous counter
- 16-bit Asynchronous counter

In Timer mode, Timer1 is incremented on every instruction cycle. In Counter mode, Timer1 is incremented on the rising edge of the external clock input T1CKI. In addition, the Counter mode clock can be synchronized to the microcontroller system clock or run asynchronously.

In Counter and Timer modules, the counter/timer clock can be gated by the Timer1 gate, which can be selected as either the $\overline{T1G}$ pin or Comparator 2 output.

If an external clock oscillator is needed (and the microcontroller is using the INTOSC without CLKOUT), Timer1 can use the LP oscillator as a clock source.

Note: In Counter mode, a falling edge must be registered by the counter prior to the first incrementing rising edge.

6.2 Timer1 Interrupt

The Timer1 register pair (TMR1H:TMR1L) increments to FFFFh and rolls over to 0000h. When Timer1 rolls over, the Timer1 interrupt flag bit (PIR1<0>) is set. To enable the interrupt on rollover, you must set these bits:

- Timer1 interrupt enable bit (PIE1<0>)
- PEIE bit (INTCON<6>)
- GIE bit (INTCON<7>)

The interrupt is cleared by clearing the TMR1IF bit in the Interrupt Service Routine.

Note: The TMR1H:TMR1L register pair and the TMR1IF bit should be cleared before enabling interrupts.

6.3 Timer1 Prescaler

Timer1 has four prescaler options allowing 1, 2, 4 or 8 divisions of the clock input. The T1CKPS bits (T1CON<5:4>) control the prescale counter. The prescale counter is not directly readable or writable; however, the prescaler counter is cleared upon a write to TMR1H or TMR1L.

6.4 Timer1 Gate

Timer1 gate source is software configurable to be the $\overline{T1G}$ pin or the output of Comparator 2. This allows the device to directly time external events using $\overline{T1G}$ or analog events using Comparator 2. See CMCON1 (Register 8-2) for selecting the Timer1 gate source. This feature can simplify the software for a Delta-Sigma A/D converter and many other applications. For more information on Delta-Sigma A/D converters, see the Microchip web site (www.microchip.com).

Note: TMR1GE bit (T1CON<6>) must be set to use either $\overline{T1G}$ or C2OUT as the Timer1 gate source. See Register 8-2 for more information on selecting the Timer1 gate source.

Timer1 gate can be inverted using the T1GINV bit (T1CON<7>), whether it originates from the $\overline{T1G}$ pin or Comparator 2 output. This configures Timer1 to measure either the active-high or active-low time between events.

FIGURE 6-2: TIMER1 INCREMENTING EDGE

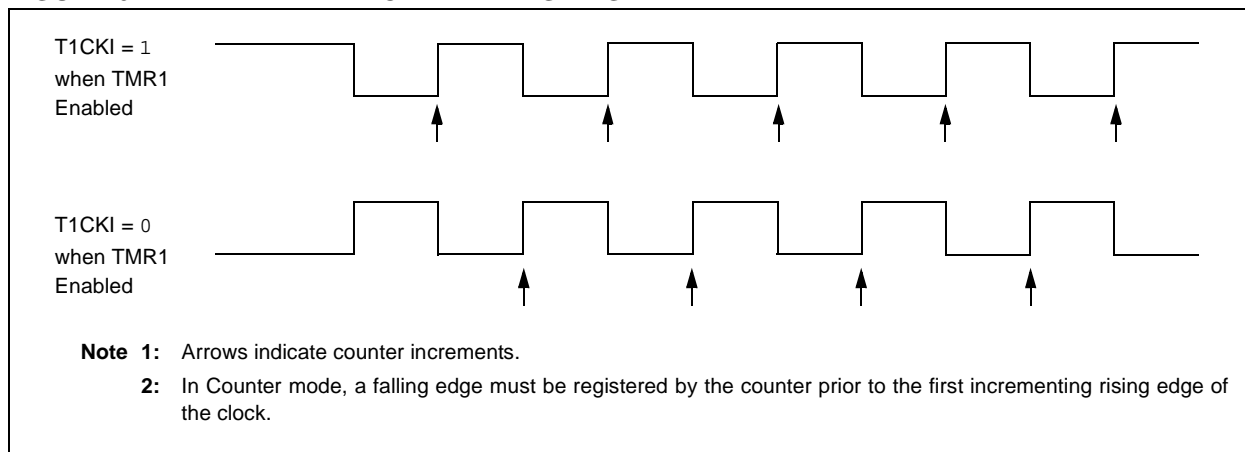

REGISTER 6-1: T1CON – TIMER1 CONTROL REGISTER (ADDRESS: 10h)

R/W-0	R/W-0	R/W-0	R/W-0	R/W-0	R/W-0	R/W-0	R/W-0
T1GINV	TMR1GE	T1CKPS1	T1CKPS0	T1OSCEN	$\overline{T1SYNC}$	TMR1CS	TMR1ON
bit 7							bit 0

- bit 7 **T1GINV:** Timer1 Gate Invert bit⁽¹⁾
 1 = Timer1 gate is inverted
 0 = Timer1 gate is not inverted
- bit 6 **TMR1GE:** Timer1 Gate Enable bit⁽²⁾
If TMR1ON = 0:
 This bit is ignored
If TMR1ON = 1:
 1 = Timer1 is on if Timer1 gate is not active
 0 = Timer1 is on
- bit 5-4 **T1CKPS<1:0>:** Timer1 Input Clock Prescale Select bits
 11 = 1:8 Prescale Value
 10 = 1:4 Prescale Value
 01 = 1:2 Prescale Value
 00 = 1:1 Prescale Value
- bit 3 **T1OSCEN:** LP Oscillator Enable Control bit
If INTOSC without CLKOUT oscillator is active:
 1 = LP oscillator is enabled for Timer1 clock
 0 = LP oscillator is off
Else:
 This bit is ignored
- bit 2 **$\overline{T1SYNC}$:** Timer1 External Clock Input Synchronization Control bit
TMR1CS = 1:
 1 = Do not synchronize external clock input
 0 = Synchronize external clock input
TMR1CS = 0:
 This bit is ignored. Timer1 uses the internal clock.
- bit 1 **TMR1CS:** Timer1 Clock Source Select bit
 1 = External clock from T1CKI pin (on the rising edge)
 0 = Internal clock (Fosc/4)
- bit 0 **TMR1ON:** Timer1 On bit
 1 = Enables Timer1
 0 = Stops Timer1

Note 1: T1GINV bit inverts the Timer1 gate logic, regardless of source.

2: TMR1GE bit must be set to use either $\overline{T1G}$ pin or C2OUT, as selected by the T1GSS bit (CMCON1<1>), as a Timer1 gate source.

Legend:

R = Readable bit	W = Writable bit	U = Unimplemented bit, read as '0'
-n = Value at POR	'1' = Bit is set	'0' = Bit is cleared x = Bit is unknown

PIC16F684

6.5 Timer1 Operation in Asynchronous Counter Mode

If control bit $\overline{T1SYNC}$ (T1CON<2>) is set, the external clock input is not synchronized. The timer continues to increment asynchronous to the internal phase clocks. The timer will continue to run during Sleep and can generate an interrupt on overflow, which will wake-up the processor. However, special precautions in software are needed to read/write the timer (see **Section 6.5.1 “Reading and Writing Timer1 in Asynchronous Counter Mode”**).

Note: The ANSEL (91h) and CMCON0 (19h) registers must be initialized to configure an analog channel as a digital input. Pins configured as analog inputs will read '0'.

6.5.1 READING AND WRITING TIMER1 IN ASYNCHRONOUS COUNTER MODE

Reading TMR1H or TMR1L while the timer is running from an external asynchronous clock will ensure a valid read (taken care of in hardware). However, the user should keep in mind that reading the 16-bit timer in two 8-bit values itself, poses certain problems, since the timer may overflow between the reads.

For writes, it is recommended that the user simply stop the timer and write the desired values. A write contention may occur by writing to the timer registers, while the register is incrementing. This may produce an unpredictable value in the timer register.

Reading the 16-bit value requires some care. Examples in the “*PICmicro® Mid-Range MCU Family Reference Manual*” (DS33023) show how to read and write Timer1 when it is running in Asynchronous mode.

6.6 Timer1 Oscillator

A crystal oscillator circuit is built-in between pins OSC1 (input) and OSC2 (amplifier output). It is enabled by setting control bit, T1OSCEN (T1CON<3>). The oscillator is a low-power oscillator rated up to 32 kHz. It will continue to run during Sleep. It is primarily intended for a 32 kHz crystal. Table 3-1 shows the capacitor selection for the Timer1 oscillator.

The Timer1 oscillator is shared with the system LP oscillator. Thus, Timer1 can use this mode only when the primary system clock is derived from the internal oscillator. As with the system LP oscillator, the user must provide a software time delay to ensure proper oscillator start-up.

TRISA5 and TRISA4 bits are set when the Timer1 oscillator is enabled. RA5 and RA4 read as '0' and TRISA5 and TRISA4 bits read as '1'.

Note: The oscillator requires a start-up and stabilization time before use. Thus, T1OSCEN should be set and a suitable delay observed prior to enabling Timer 1.

6.7 Timer1 Operation During Sleep

Timer1 can only operate during Sleep when setup in Asynchronous Counter mode. In this mode, an external crystal or clock source can be used to increment the counter. To set up the timer to wake the device:

- Timer1 must be on (T1CON<0>)
- TMR1IE bit (PIE1<0>) must be set
- PEIE bit (INTCON<6>) must be set

The device will wake-up on an overflow. If the GIE bit (INTCON<7>) is set, the device will wake-up and jump to the Interrupt Service Routine (0004h) on an overflow. If the GIE bit is clear, execution will continue with the next instruction.

TABLE 6-1: REGISTERS ASSOCIATED WITH TIMER1

Addr	Name	Bit 7	Bit 6	Bit 5	Bit 4	Bit 3	Bit 2	Bit 1	Bit 0	Value on POR, BOD	Value on all other Resets
0Bh/8Bh	INTCON	GIE	PEIE	T0IE	INTE	RAIE	T0IF	INTF	RAIF	0000 0000	0000 0000
0Ch	PIR1	EEIF	ADIF	CCP1IF	C2IF	C1IF	OSFIF	TMR2IF	TMR1IF	0000 0000	0000 0000
0Eh	TMR1L	Holding register for the Least Significant Byte of the 16-bit TMR1 register								xxxx xxxx	uuuu uuuu
0Fh	TMR1H	Holding register for the Most Significant Byte of the 16-bit TMR1 register								xxxx xxxx	uuuu uuuu
10h	T1CON	T1GINV	TMR1GE	T1CKPS1	T1CKPS0	T1OSCEN	$\overline{T1SYNC}$	TMR1CS	TMR1ON	0000 0000	uuuu uuuu
1Ah	CMCON1	—	—	—	—	—	—	T1GSS	C2SYNC	---- --10	---- --10
8Ch	PIE1	EEIE	ADIE	CCP1IE	C2IE	C1IE	OSFIE	TMR2IE	TMR1IE	0000 0000	0000 0000

Legend: x = unknown, u = unchanged, — = unimplemented, read as '0'. Shaded cells are not used by the Timer1 module.

7.0 TIMER2 MODULE

The Timer2 module timer has the following features:

- 8-bit timer (TMR2 register)
- 8-bit period register (PR2)
- Readable and writable (both registers)
- Software programmable prescaler (1:1, 1:4, 1:16)
- Software programmable postscaler (1:1 to 1:16)
- Interrupt on TMR2 match with PR2

Timer2 has a control register shown in Register 7-1. TMR2 can be shut-off by clearing control bit, TMR2ON (T2CON<2>), to minimize power consumption. Figure 7-1 is a simplified block diagram of the Timer2 module. The prescaler and postscaler selection of Timer2 are controlled by this register.

7.1 Timer2 Operation

Timer2 can be used as the PWM time base for the PWM mode of the ECCP module. The TMR2 register is readable and writable, and is cleared on any device Reset. The input clock (FOSC/4) has a prescale option of 1:1, 1:4 or 1:16, selected by control bits T2CKPS<1:0> (T2CON<1:0>). The match output of TMR2 goes through a 4-bit postscaler (which gives a 1:1 to 1:16 scaling inclusive) to generate a TMR2 interrupt (latched in flag bit, TMR2IF (PIR1<1>)).

The prescaler and postscaler counters are cleared when any of the following occurs:

- A write to the TMR2 register
- A write to the T2CON register
- Any device Reset (Power-on Reset, $\overline{\text{MCLR}}$ Reset, Watchdog Timer Reset, or Brown-out Reset)

TMR2 is not cleared when T2CON is written.

REGISTER 7-1: T2CON — TIMER2 CONTROL REGISTER (ADDRESS: 12h)

U-0	R/W-0	R/W-0	R/W-0	R/W-0	R/W-0	R/W-0	R/W-0
—	TOUTPS3	TOUTPS2	TOUTPS1	TOUTPS0	TMR2ON	T2CKPS1	T2CKPS0
bit 7							bit 0

- bit 7 **Unimplemented:** Read as '0'
- bit 6-3 **TOUTPS<3:0>:** Timer2 Output Postscale Select bits
 0000 =1:1 postscale
 0001 =1:2 postscale
 •
 •
 •
 1111 =1:16 postscale
- bit 2 **TMR2ON:** Timer2 On bit
 1 =Timer2 is on
 0 =Timer2 is off
- bit 1-0 **T2CKPS<1:0>:** Timer2 Clock Prescale Select bits
 00 = Prescaler is 1
 01 = Prescaler is 4
 1x = Prescaler is 16

Legend:

R = Readable bit	W = Writable bit	U = Unimplemented bit, read as '0'
-n = Value at POR	'1' = Bit is set	'0' = Bit is cleared x = Bit is unknown

PIC16F684

7.2 Timer2 Interrupt

The Timer2 module has an 8-bit period register, PR2. Timer2 increments from 00h until it matches PR2 and then resets to 00h on the next increment cycle. PR2 is a readable and writable register. The PR2 register is initialized to FFh upon Reset.

FIGURE 7-1: TIMER2 BLOCK DIAGRAM

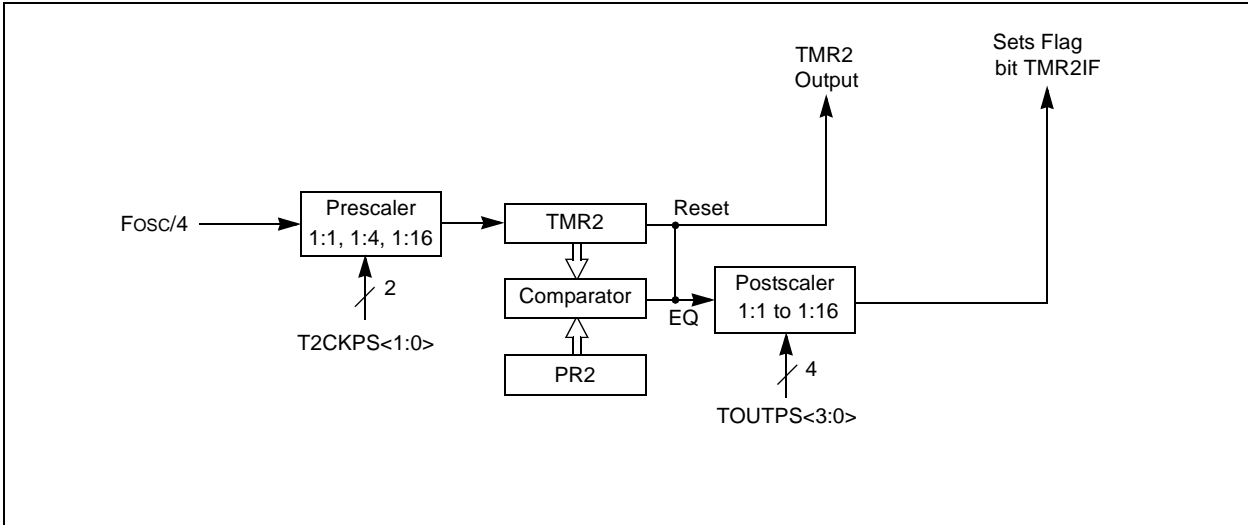

TABLE 7-1: REGISTERS ASSOCIATED WITH TIMER2

Addr	Name	Bit 7	Bit 6	Bit 5	Bit 4	Bit 3	Bit 2	Bit 1	Bit 0	Value on POR, BOD	Value on all other Resets
0Bh/ 8Bh	INTCON	GIE	PEIE	T0IE	INTE	RAIE	T0IF	INTF	RAIF	0000 0000	0000 0000
0Ch	PIR1	EEIF	ADIF	CCP1IF	C2IF	C1IF	OSFIF	TMR2IF	TMR1IF	0000 0000	0000 0000
11h	TMR2	Holding register for the 8-bit TMR2 register								0000 0000	0000 0000
12h	T2CON	—	TOUTPS3	TOUTPS2	TOUTPS1	TOUTPS0	TMR2ON	T2CKPS1	T2CKPS0	-000 0000	-000 0000
8Ch	PIE1	EEIE	ADIE	CCP1IE	C2IE	C1IE	OSFIE	TMR2IE	TMR1IE	0000 0000	0000 0000
92h	PR2	Timer2 Module Period register								1111 1111	1111 1111

Legend: x = unknown, u = unchanged, — = unimplemented, read as '0'. Shaded cells are not used by the Timer2 module.

8.0 COMPARATOR MODULE

The comparator module contains two analog comparators. The inputs to the comparators are multiplexed with I/O port pins RA0, RA1, RC0 and RC1, while the outputs are multiplexed to pins RA2 and RC4. An on-chip Comparator Voltage Reference (CVREF) can also be applied to the inputs of the comparators.

The CMCON0 register (Register 8-1) controls the comparator input and output multiplexers. A block diagram of the various comparator configurations is shown in Figure 8-3.

REGISTER 8-1: CMCON0 – COMPARATOR CONFIGURATION REGISTER (ADDRESS: 19h)

R-0	R-0	R/W-0	R/W-0	R/W-0	R/W-0	R/W-0	R/W-0	
C2OUT	C1OUT	C2INV	C1INV	CIS	CM2	CM1	CM0	
bit 7								bit 0

bit 7 **C2OUT**: Comparator 2 Output bit

When C2INV = 0:

1 = C2 VIN+ > C2 VIN-

0 = C2 VIN+ < C2 VIN-

When C2INV = 1:

1 = C2 VIN+ < C2 VIN-

0 = C2 VIN+ > C2 VIN-

bit 6 **C1OUT**: Comparator 1 Output bit

When C1INV = 0:

1 = C1 VIN+ > C1 VIN-

0 = C1 VIN+ < C1 VIN-

When C1INV = 1:

1 = C1 VIN+ < C1 VIN-

0 = C1 VIN+ > C1 VIN-

bit 5 **C2INV**: Comparator 2 Output Inversion bit

1 = C2 output inverted

0 = C2 output not inverted

bit 4 **C1INV**: Comparator 1 Output Inversion bit

1 = C1 Output inverted

0 = C1 Output not inverted

bit 3 **CIS**: Comparator Input Switch bit

When CM<2:0> = 010:

1 = C1 VIN- connects to RA0/AN0

C2 VIN- connects to RC0/AN4

0 = C1 VIN- connects to RA1/AN1

C2 VIN- connects to RC1/AN5

When CM<2:0> = 001:

1 = C1 VIN- connects to RA0/AN0

0 = C1 VIN- connects to RA1/AN1

bit 2-0 **CM<2:0>**: Comparator Mode bits

Figure 8-3 shows the Comparator modes and CM<2:0> bit settings

Legend:

R = Readable bit

W = Writable bit

U = Unimplemented bit, read as '0'

-n = Value at POR

'1' = Bit is set

'0' = Bit is cleared

x = Bit is unknown

PIC16F684

8.1 Comparator Operation

A single comparator is shown in Figure 8-1 along with the relationship between the analog input levels and the digital output. When the analog input at V_{IN+} is less than the analog input V_{IN-} , the output of the comparator is a digital low level. When the analog input at V_{IN+} is greater than the analog input V_{IN-} , the output of the comparator is a digital high level. The shaded areas of the output of the comparator in Figure 8-1 represent the uncertainty due to input offsets and response time.

Note: To use C_{IN+} and C_{IN-} pins as analog inputs, the appropriate bits must be programmed in the $CMCON0$ (19h) register.

The polarity of the comparator output can be inverted by setting the $CxINV$ bits ($CMCON0<5:4>$). Clearing $CxINV$ results in a non-inverted output. A complete table showing the output state versus input conditions and the polarity bit is shown in Table 8-1.

TABLE 8-1: OUTPUT STATE VS. INPUT CONDITIONS

Input Conditions	C_{INV}	$CxOUT$
$V_{IN-} > V_{IN+}$	0	0
$V_{IN-} < V_{IN+}$	0	1
$V_{IN-} > V_{IN+}$	1	1
$V_{IN-} < V_{IN+}$	1	0

FIGURE 8-1: SINGLE COMPARATOR

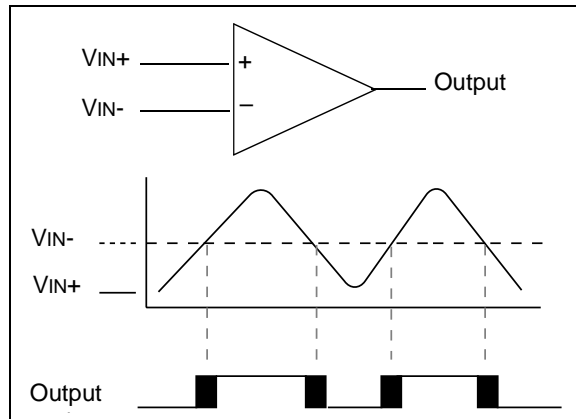

8.2 Analog Input Connection Considerations

A simplified circuit for an analog input is shown in Figure 8-2. Since the analog pins are connected to a digital output, they have reverse biased diodes to V_{DD} and V_{SS} . The analog input, therefore, must be between V_{SS} and V_{DD} . If the input voltage deviates from this range by more than 0.6V in either direction, one of the diodes is forward biased and a latch-up may occur. A maximum source impedance of 10 k Ω is recommended for the analog sources. Any external component connected to an analog input pin, such as a capacitor or a Zener diode, should have very little leakage current.

Note 1: When reading the PORT register, all pins configured as analog inputs will read as a '0'. Pins configured as digital inputs will convert as analog inputs according to the input specification.

2: Analog levels on any pin defined as a digital input may cause the input buffer to consume more current than is specified.

FIGURE 8-2: ANALOG INPUT MODEL

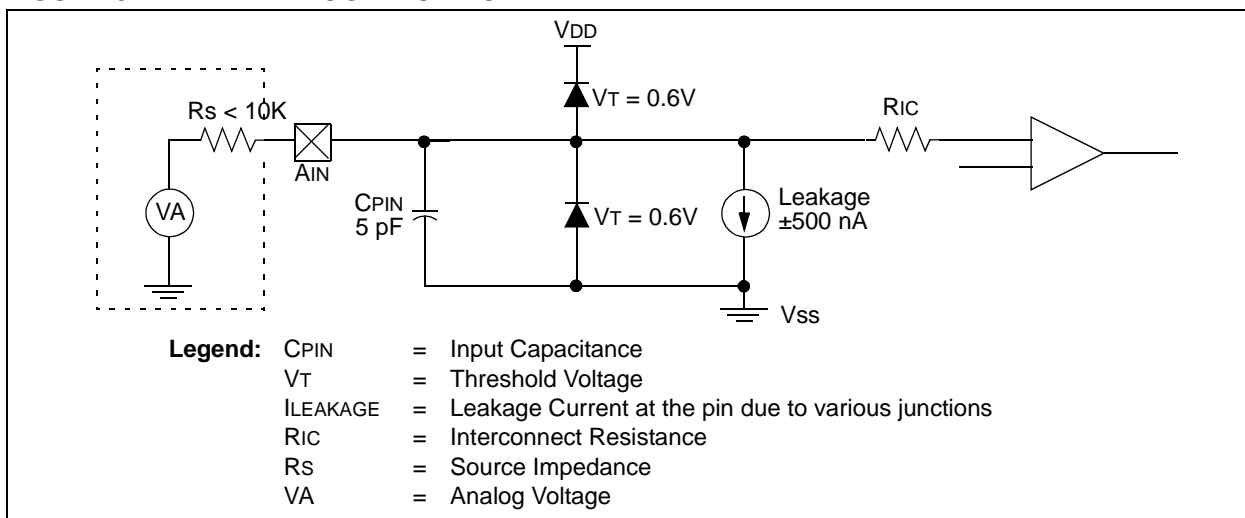

8.3 Comparator Configuration

There are eight modes of operation for the comparators. The CMCON0 register is used to select these modes. Figure 8-3 shows the eight possible modes.

If the Comparator mode is changed, the comparator output level may not be valid for the specified mode change delay shown in **Section 15.0 “Electrical Specifications”**.

Note: Comparator interrupts should be disabled during a Comparator mode change. Otherwise, a false interrupt may occur.

FIGURE 8-3: COMPARATOR I/O OPERATING MODES

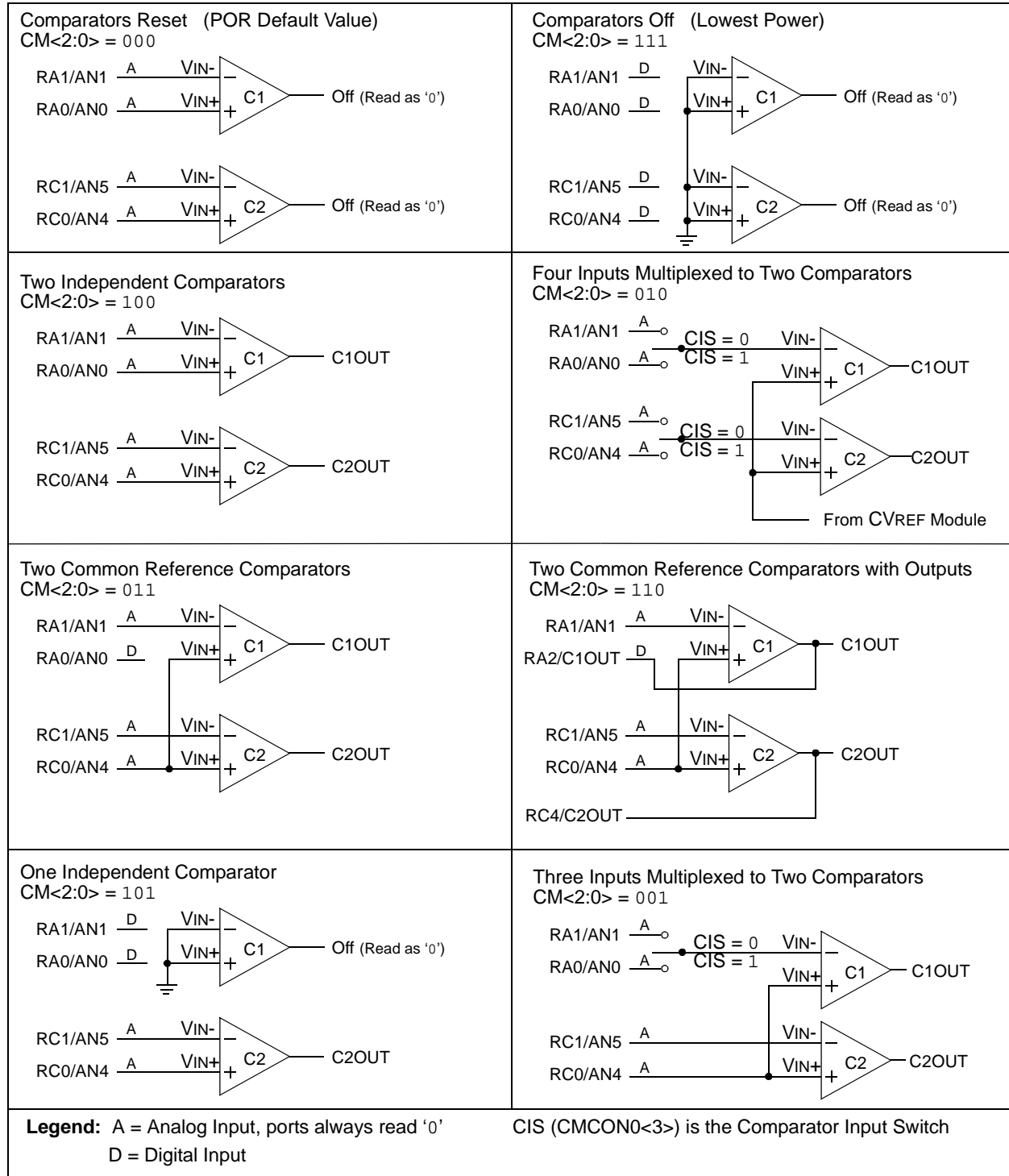

PIC16F684

FIGURE 8-4: INVERTIBLE COMPARATOR C1 OUTPUT BLOCK DIAGRAM

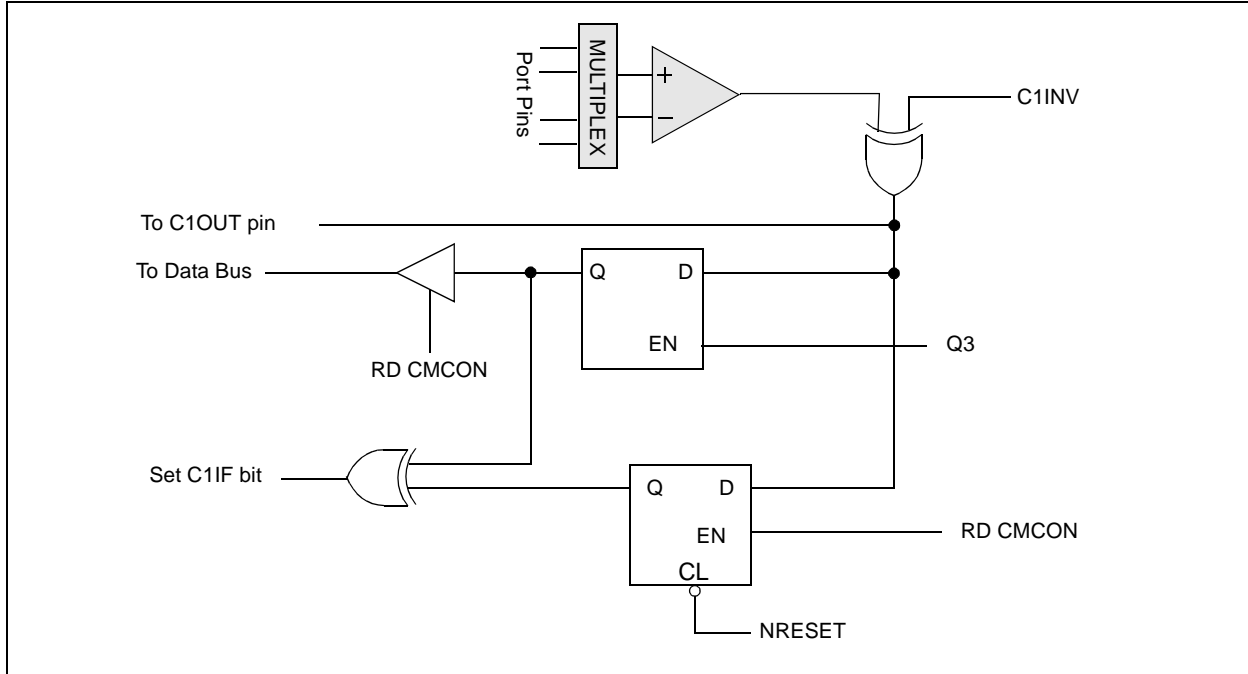
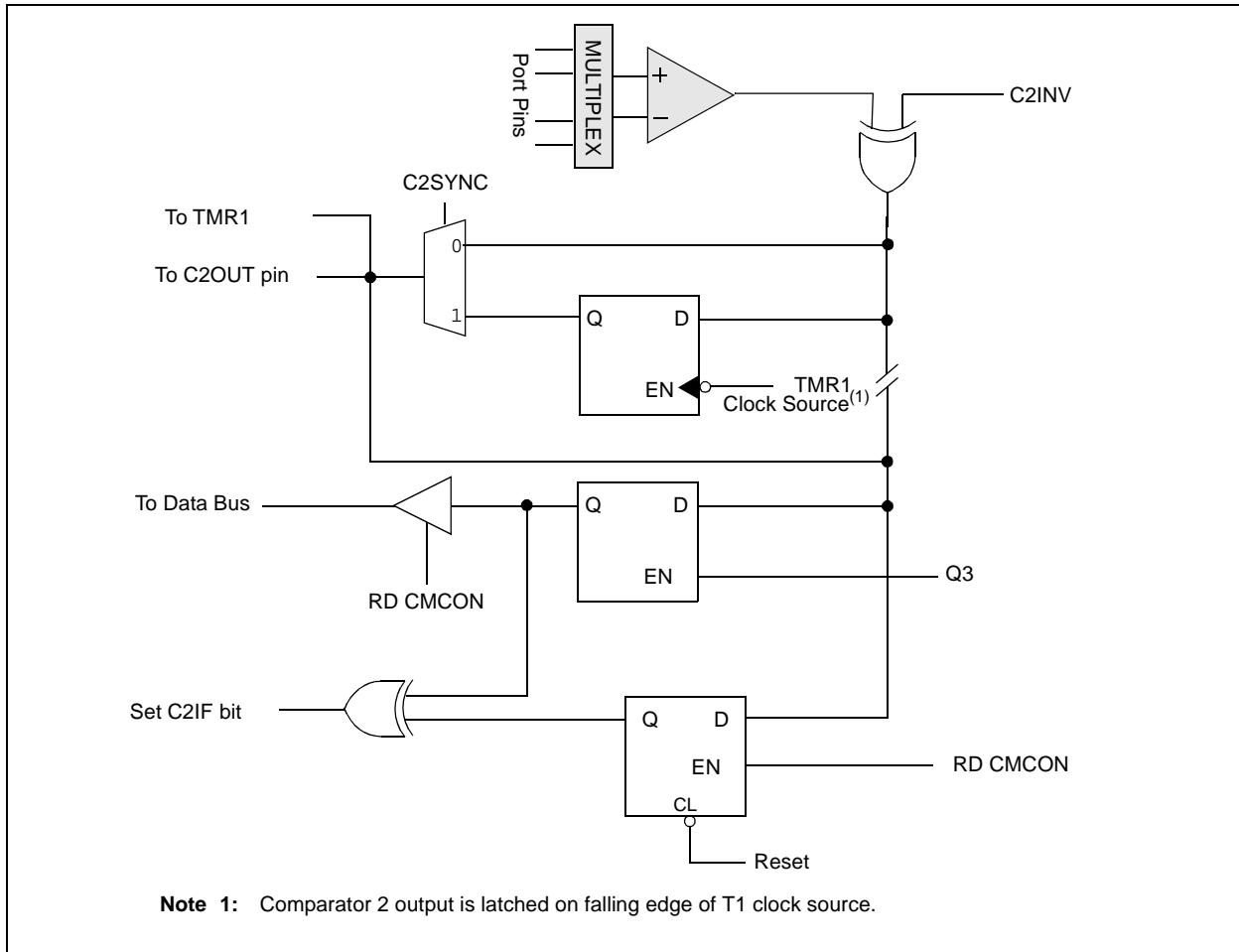

FIGURE 8-5: INVERTIBLE COMPARATOR C2 OUTPUT BLOCK DIAGRAM



REGISTER 8-2: CMCON1 – COMPARATOR CONFIGURATION REGISTER (ADDRESS: 1Ah)

U-0	U-0	U-0	U-0	U-0	U-0	R/W-1	R/W-0
—	—	—	—	—	—	T1GSS	C2SYNC
bit 7						bit 0	

bit 7-2: **Unimplemented:** Read as '0'

bit 1 **T1GSS:** Timer1 Gate Source Select bit

1 = Timer1 gate source is $\overline{T1G}$ pin (RA4 must be configured as digital input)

0 = Timer1 gate source is comparator 2 output

bit 0 **C2SYNC:** Comparator 2 Synchronize bit

1 = C2 output synchronized with falling edge of Timer1 clock

0 = C2 output not synchronized with Timer1 clock

Legend:

R = Readable bit

W = Writable bit

U = Unimplemented bit, read as '0'

-n = Value at POR

'1' = Bit is set

'0' = Bit is cleared

x = Bit is unknown

8.4 Comparator Outputs

The comparator outputs are read through the CMCON0 register. These bits are read-only. The comparator outputs may also be directly output to the RA2 and RC4 I/O pins. When enabled, multiplexers in the output path of the RA2 and RC4 pins will switch and the output of each pin will be the unsynchronized output of the comparator. The uncertainty of each of the comparators is related to the input offset voltage and the response time given in the specifications. Figure 8-4 and Figure 8-5 show the output block diagram for Comparator 1 and 2.

The TRIS bits will still function as an output enable/disable for the RA2 and RC4 pins while in this mode.

The polarity of the comparator outputs can be changed using the C1INV and C2INV bits (CMCON0<5:4>).

Timer1 gate source can be configured to use the $\overline{T1G}$ pin or Comparator 2 output as selected by the T1GSS bit (CMCON1<1>). This feature can be used to time the duration or interval of analog events. The output of Comparator 2 can also be synchronized with Timer1 by setting the C2SYNC bit (CMCON1<0>). When enabled, the output of Comparator 2 is latched on the falling edge of Timer1 clock source. If a prescaler is used with Timer1, Comparator 2 is latched after the prescaler. To prevent a race condition, the Comparator 2 output is latched on the falling edge of the Timer1 clock source and Timer1 increments on the rising edge of its clock source. See the Comparator 2 Block Diagram (Figure 8-5) and the Timer1 Block Diagram (Figure 6-1) for more information.

It is recommended to synchronize Comparator 2 with Timer1 by setting the C2SYNC bit when Comparator 2 is used as the Timer1 gate source. This ensures Timer1 does not miss an increment if Comparator 2 changes during an increment.

8.5 Comparator Interrupts

The comparator interrupt flags are set whenever there is a change in the output value of its respective comparator. Software will need to maintain information about the status of the output bits, as read from CMCON0<7:6>, to determine the actual change that has occurred. The CxIF bits, PIR1<4:3>, are the Comparator Interrupt Flags. This bit must be reset in software by clearing it to '0'. Since it is also possible to write a '1' to this register, a simulated interrupt may be initiated.

The CxIE bits (PIE1<4:3>) and the PEIE bit (INTCON<6>) must be set to enable the interrupts. In addition, the GIE bit must also be set. If any of these bits are cleared, the interrupt is not enabled, though the CxIF bits will still be set if an interrupt condition occurs.

The user, in the Interrupt Service Routine, can clear the interrupt in the following manner:

- Any read or write of CMCON0. This will end the mismatch condition.
- Clear flag bit CxIF.

A mismatch condition will continue to set flag bit CxIF. Reading CMCON0 will end the mismatch condition and allow flag bit CxIF to be cleared.

Note: If a change in the CMCON0 register (CxOUT) should occur when a read operation is being executed (start of the Q2 cycle), then the CxIF (PIR1<4:3>) interrupt flag may not get set.

PIC16F684

8.6 Comparator Reference

The comparator module also allows the selection of an internally generated voltage reference for one of the comparator inputs. The VRCON register (Register 8-3) controls the voltage reference module shown in Figure 8-6.

8.6.1 CONFIGURING THE VOLTAGE REFERENCE

The voltage reference can output 32 distinct voltage levels, 16 in a high range and 16 in a low range.

The following equation determines the output voltages:

EQUATION 8-1:

$$VRR = 1 \text{ (low range): } CVREF = (VR3:VR0/24) \times VDD$$

$$VRR = 0 \text{ (high range):}$$

$$CVREF = (VDD/4) + (VR3:VR0 \times VDD/32)$$

8.6.2 VOLTAGE REFERENCE ACCURACY/ERROR

The full range of VSS to VDD cannot be realized due to the construction of the module. The transistors on the top and bottom of the resistor ladder network (Figure 8-6) keep CVREF from approaching VSS or VDD. The exception is when the module is disabled by clearing the VREN bit (VRCON<7>). When disabled, the reference voltage is VSS when VR<3:0> is '0000' and the VRR (VRCON<5>) bit is set. This allows the comparators to detect a zero-crossing and not consume CVREF module current.

The voltage reference is VDD derived and therefore, the CVREF output changes with fluctuations in VDD. The tested absolute accuracy of the comparator voltage Reference can be found in **Section 15.0 "Electrical Specifications"**.

FIGURE 8-6: COMPARATOR VOLTAGE REFERENCE BLOCK DIAGRAM

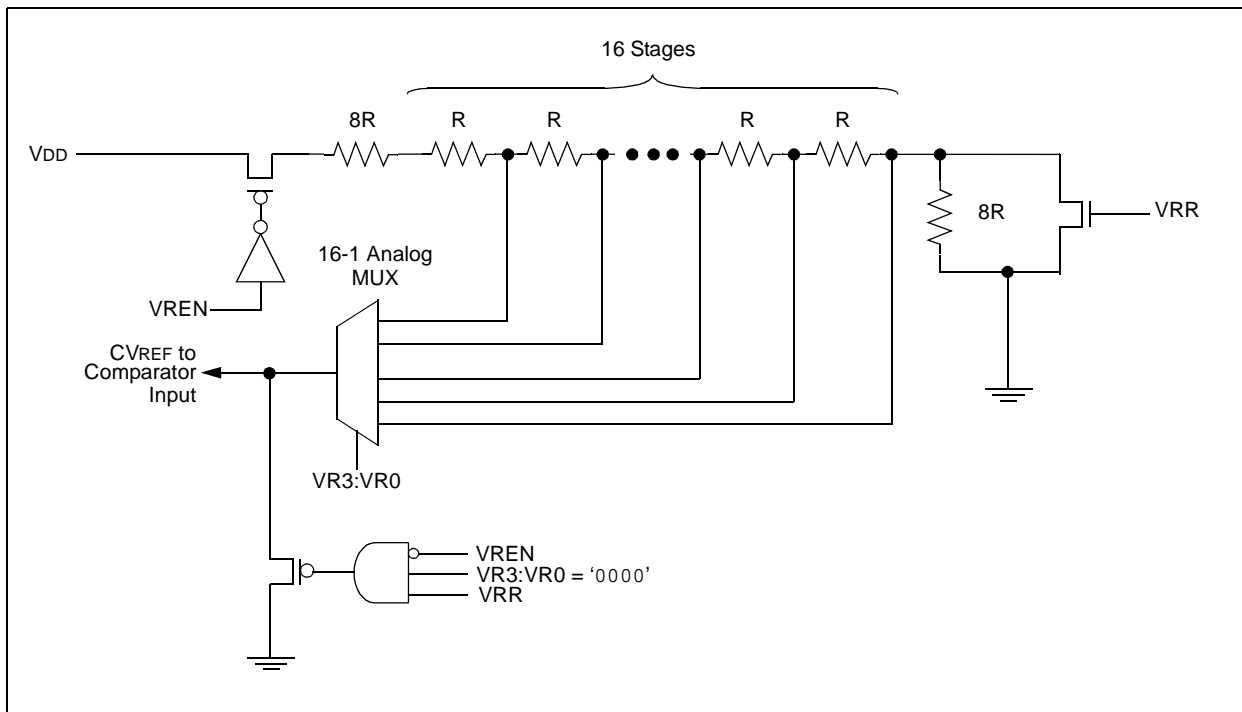

8.7 Comparator Response Time

Response time is the minimum time, after selecting a new reference voltage or input source, before the comparator output is ensured to have a valid level. If the internal reference is changed, the maximum delay of the internal voltage reference must be considered when using the comparator outputs. Otherwise, the maximum delay of the comparators should be used (Table 15-8).

8.8 Operation During Sleep

The comparators and voltage reference, if enabled before entering Sleep mode, remain active during Sleep. This results in higher Sleep currents than shown in the power-down specifications. The additional current consumed by the comparator and the voltage reference is shown separately in the specifications. To minimize power consumption while in Sleep mode, turn off the comparator, $CM<2:0> = 111$, and voltage reference, $VRCON<7> = 0$.

While the comparator is enabled during Sleep, an interrupt will wake-up the device. If the GIE bit ($INTCON<7>$) is set, the device will jump to the interrupt vector (0004h), and if clear, continues execution with the next instruction. If the device wakes up from Sleep, the contents of the $CMCON0$, $CMCON1$ and $VRCON$ registers are not affected.

8.9 Effects of a Reset

A device Reset forces the $CMCON0$, $CMCON1$ and $VRCON$ registers to their Reset states. This forces the comparator module to be in the Comparator Reset mode, $CM<2:0> = 000$ and the voltage reference to its off state. Thus, all potential inputs are analog inputs with the comparator and voltage reference disabled to consume the smallest current possible.

PIC16F684

REGISTER 8-3: VRCON – VOLTAGE REFERENCE CONTROL REGISTER (ADDRESS: 99h)

R/W-0	U-0	R/W-0	R/W-0	R/W-0	R/W-0	R/W-0	R/W-0
VREN	—	VRR	—	VR3	VR2	VR1	VR0
bit 7							bit 0

- bit 7 **VREN:** CVREF Enable bit
1 = CVREF circuit powered on
0 = CVREF circuit powered down, no IDD drain and CVREF = VSS
- bit 6 **Unimplemented:** Read as '0'
- bit 5 **VRR:** CVREF Range Selection bit
1 = Low range
0 = High range
- bit 4 **Unimplemented:** Read as '0'
- bit 3-0 **VR<3:0>:** CVREF Value Selection $0 \leq VR<3:0> \leq 15$
When VRR = 1: CVREF = (VR<3:0>/24) * VDD
When VRR = 0: CVREF = VDD/4 + (VR<3:0>/32) * VDD

Legend:

R = Readable bit W = Writable bit U = Unimplemented bit, read as '0'
-n = Value at POR '1' = Bit is set '0' = Bit is cleared x = Bit is unknown

TABLE 8-2: REGISTERS ASSOCIATED WITH COMPARATOR MODULE

Address	Name	Bit 7	Bit 6	Bit 5	Bit 4	Bit 3	Bit 2	Bit 1	Bit 0	Value on POR, BOD	Value on all other Resets
0Bh/8Bh	INTCON	GIE	PEIE	T0IE	INTE	RAIE	T0IF	INTF	RAIF	0000 0000	0000 0000
0Ch	PIR1	EEIF	ADIF	CCP1IF	C2IF	C1IF	OSFIF	TMR2IF	TMR1IF	0000 0000	0000 0000
19h	CMCON0	C2OUT	C1OUT	C2INV	C1INV	CIS	CM2	CM1	CM0	0000 0000	0000 0000
1Ah	CMCON1	—	—	—	—	—	—	T1GSS	C2SYNC	---- --10	---- --10
85h	TRISA	—	—	TRISA5	TRISA4	TRISA3	TRISA2	TRISA1	TRISA0	--11 1111	--11 1111
87h	TRISC	—	—	TRISC5	TRISC4	TRISC3	TRISC2	TRISC1	TRISC0	--11 1111	--11 1111
8Ch	PIE1	EEIE	ADIE	CCP1IE	C2IE	C1IE	OSFIE	TMR2IE	TMR1IE	0000 0000	0000 0000
99h	VRCON	VREN	—	VRR	—	VR3	VR2	VR1	VR0	0-0- 0000	0-0- 0000

Legend: x = unknown, u = unchanged, — = unimplemented, read as '0'. Shaded cells are not used by the Capture, Compare or Timer1 module.

9.0 ANALOG-TO-DIGITAL CONVERTER (A/D) MODULE

The Analog-to-Digital converter (A/D) allows conversion of an analog input signal to a 10-bit binary representation of that signal. The PIC16F684 has eight analog inputs, multiplexed into one sample and hold

circuit. The output of the sample and hold is connected to the input of the converter. The converter generates a binary result via successive approximation and stores the result in a 10-bit register. The voltage reference used in the conversion is software selectable to either VDD or a voltage applied by the VREF pin. Figure 9-1 shows the block diagram of the A/D on the PIC16F684.

FIGURE 9-1: A/D BLOCK DIAGRAM

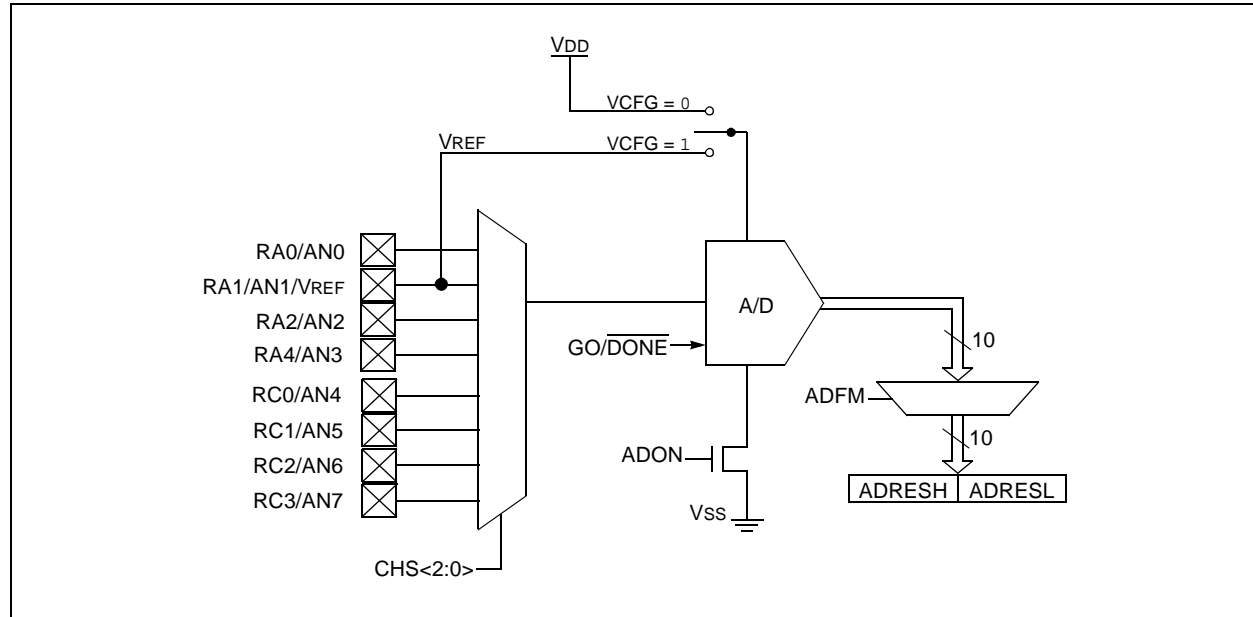

9.1 A/D Configuration and Operation

There are three registers available to control the functionality of the A/D module:

1. ANSEL (Register 9-1)
2. ADCON0 (Register 9-2)
3. ADCON1 (Register 9-3)

9.1.1 ANALOG PORT PINS

The ANS<7:0> bits (ANSEL<7:0>) and the TRIS bits control the operation of the A/D port pins. Set the corresponding TRIS bits to set the pin output driver to its high-impedance state. Likewise, set the corresponding ANSEL bit to disable the digital input buffer.

Note: Analog voltages on any pin that is defined as a digital input may cause the input buffer to conduct excess current.

9.1.2 CHANNEL SELECTION

There are eight analog channels on the PIC16F684, AN0 through AN7. The CHS<2:0> bits (ADCON0<4:2>) control which channel is connected to the sample and hold circuit.

9.1.3 VOLTAGE REFERENCE

There are two options for the voltage reference to the A/D converter: either VDD is used, or an analog voltage applied to VREF is used. The VCFG bit (ADCON0<6>) controls the voltage reference selection. If VCFG is set, then the voltage on the VREF pin is the reference; otherwise, VDD is the reference.

PIC16F684

9.1.4 CONVERSION CLOCK

The A/D conversion cycle requires 11 TAD. The source of the conversion clock is software selectable via the ADCS bits (ADCON1<6:4>). There are seven possible clock options:

- Fosc/2
- Fosc/4
- Fosc/8

- Fosc/16
- Fosc/32
- Fosc/64
- FRC (dedicated internal oscillator)

For correct conversion, the A/D conversion clock (1/TAD) must be selected to ensure a minimum TAD of 1.6 μ s. Table 9-1 shows a few TAD calculations for selected frequencies.

TABLE 9-1: TAD VS. DEVICE OPERATING FREQUENCIES

A/D Clock Source (TAD)		Device Frequency			
Operation	ADCS2:ADCS0	20 MHz	5 MHz	4 MHz	1.25 MHz
2 TOSC	000	100 ns ⁽²⁾	400 ns ⁽²⁾	500 ns ⁽²⁾	1.6 μ s
4 TOSC	100	200 ns ⁽²⁾	800 ns ⁽²⁾	1.0 μ s ⁽²⁾	3.2 μ s
8 TOSC	001	400 ns ⁽²⁾	1.6 μ s	2.0 μ s	6.4 μ s
16 TOSC	101	800 ns ⁽²⁾	3.2 μ s	4.0 μ s	12.8 μ s ⁽³⁾
32 TOSC	010	1.6 μ s	6.4 μ s	8.0 μ s ⁽³⁾	25.6 μ s ⁽³⁾
64 TOSC	110	3.2 μ s	12.8 μ s ⁽³⁾	16.0 μ s ⁽³⁾	51.2 μ s ⁽³⁾
A/D RC	x11	2-6 μ s ^(1,4)	2-6 μ s ^(1,4)	2-6 μ s ^(1,4)	2-6 μ s ^(1,4)

Legend: Shaded cells are outside of recommended range.

Note 1: The A/D RC source has a typical TAD time of 4 μ s for VDD > 3.0V.

2: These values violate the minimum required TAD time.

3: For faster conversion times, the selection of another clock source is recommended.

4: When the device frequency is greater than 1 MHz, the A/D RC clock source is only recommended if the conversion will be performed during Sleep.

9.1.5 STARTING A CONVERSION

The A/D conversion is initiated by setting the GO/DONE bit (ADCON0<1>). When the conversion is complete, the A/D module:

- Clears the GO/DONE bit
- Sets the ADIF flag (PIR1<6>)
- Generates an interrupt (if enabled)

If the conversion must be aborted, the GO/DONE bit can be cleared in software. The ADRESH:ADRESL registers will not be updated with the partially complete A/D conversion sample. Instead, the ADRESH:ADRESL registers will retain the value of the previous conversion. After an aborted conversion, a 2 TAD delay is required before another acquisition can be initiated. Following the delay, an input acquisition is automatically started on the selected channel.

Note: The GO/DONE bit should not be set in the same instruction that turns on the A/D.

FIGURE 9-2: A/D CONVERSION TAD CYCLES

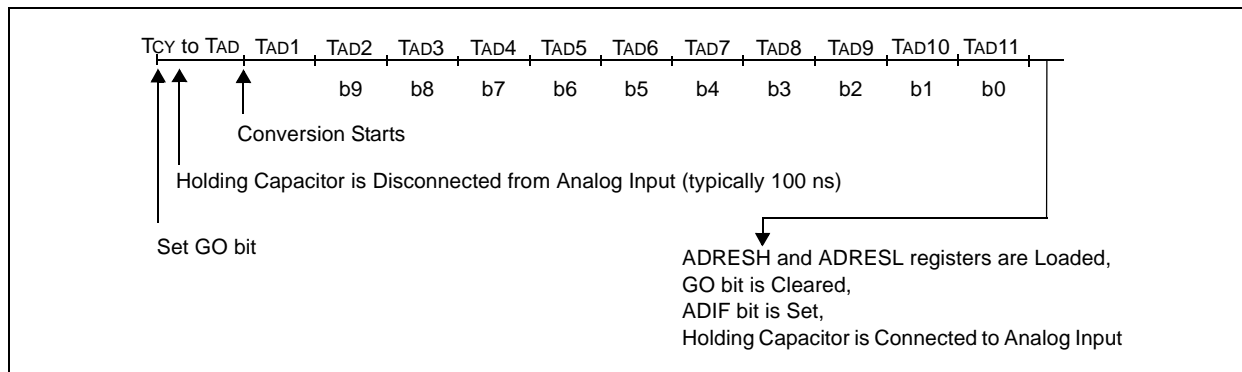

9.1.6 CONVERSION OUTPUT

The A/D conversion can be supplied in two formats: left or right shifted. The ADFM bit (ADCON0<7>) controls the output format. Figure 9-3 shows the output formats.

FIGURE 9-3: 10-BIT A/D RESULT FORMAT

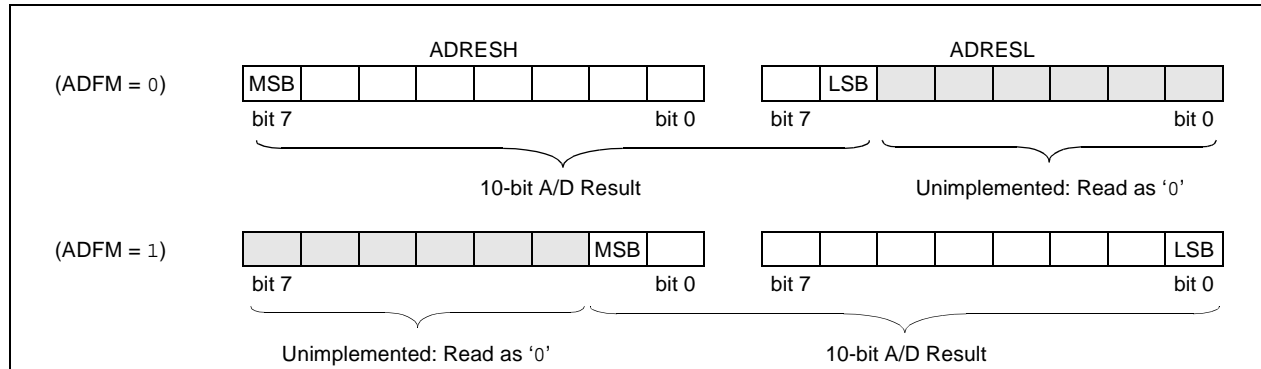

REGISTER 9-1: ANSEL – ANALOG SELECT REGISTER (ADDRESS: 91h)

R/W-1	R/W-1	R/W-1	R/W-1	R/W-1	R/W-1	R/W-1	R/W-1	
ANS7	ANS6	ANS5	ANS4	ANS3	ANS2	ANS1	ANS0	
							bit 7	bit 0

bit 7-0: **ANS<7:0>**: Analog Select bits

Analog select between analog or digital function on pins AN<7:0>, respectively.

1 = Analog input. Pin is assigned as analog input⁽¹⁾.

0 = Digital I/O. Pin is assigned to port or special function.

Note 1: Setting a pin to an analog input automatically disables the digital input circuitry, weak pull-ups, and interrupt-on-change if available. The corresponding TRIS bit must be set to input mode in order to allow external control of the voltage on the pin.

Legend:

R = Readable bit W = Writable bit U = Unimplemented bit, read as '0'
 -n = Value at POR '1' = Bit is set '0' = Bit is cleared x = Bit is unknown

PIC16F684

REGISTER 9-2: ADCON0 – A/D CONTROL REGISTER (ADDRESS: 1Fh)

R/W-0	R/W-0	U-0	R/W-0	R/W-0	R/W-0	R/W-0	R/W-0
ADFM	VCFG	—	CHS2	CHS1	CHS0	GO/DONE	ADON
bit 7						bit 0	

- bit 7 **ADFM:** A/D Result Formed Select bit
1 = Right justified
0 = Left justified
- bit 6 **VCFG:** Voltage Reference bit
1 = VREF pin
0 = VDD
- bit 5 **Unimplemented:** Read as '0'
- bit 4-2 **CHS<2:0>:** Analog Channel Select bits
000 = Channel 00 (AN0)
001 = Channel 01 (AN1)
010 = Channel 02 (AN2)
011 = Channel 03 (AN3)
100 = Channel 04 (AN4)
101 = Channel 05 (AN5)
110 = Channel 06 (AN6)
111 = Channel 07 (AN7)
- bit 1 **GO/DONE:** A/D Conversion Status bit
1 = A/D conversion cycle in progress. Setting this bit starts an A/D conversion cycle.
This bit is automatically cleared by hardware when the A/D conversion has completed.
0 = A/D conversion completed/not in progress
- bit 0 **ADON:** A/D Conversion Status bit
1 = A/D converter module is operating
0 = A/D converter is shut-off and consumes no operating current

Legend:			
R = Readable bit	W = Writable bit	U = Unimplemented bit, read as '0'	
-n = Value at POR	'1' = Bit is set	'0' = Bit is cleared	x = Bit is unknown

REGISTER 9-3: ADCON1 – A/D CONTROL REGISTER 1 (ADDRESS: 9Fh)

U-0	R/W-0	R/W-0	R/W-0	U-0	U-0	U-0	U-0
—	ADCS2	ADCS1	ADCS0	—	—	—	—
bit 7				bit 0			

- bit 7: **Unimplemented:** Read as '0'
- bit 6-4: **ADCS<2:0>:** A/D Conversion Clock Select bits
000 = Fosc/2
001 = Fosc/8
010 = Fosc/32
x11 = FRC (clock derived from a dedicated internal oscillator = 500 kHz max)
100 = Fosc/4
101 = Fosc/16
110 = Fosc/64
- bit 3-0: **Unimplemented:** Read as '0'

Legend:			
R = Readable bit	W = Writable bit	U = Unimplemented bit, read as '0'	
-n = Value at POR	'1' = Bit is set	'0' = Bit is cleared	x = Bit is unknown

9.1.7 CONFIGURING THE A/D

After the A/D module has been configured as desired, the selected channel must be acquired before the conversion is started. The analog input channels must have their corresponding TRIS bits selected as inputs.

To determine sample time, see **Section 15.0 “Electrical Specifications”**. After this sample time has elapsed, the A/D conversion can be started.

These steps should be followed for an A/D conversion:

1. Configure the A/D module:
 - Configure analog/digital I/O (ANSEL)
 - Configure voltage reference (ADCON0)
 - Select A/D input channel (ADCON0)
 - Select A/D conversion clock (ADCON1)
 - Turn on A/D module (ADCON0)
2. Configure A/D interrupt (if desired):
 - Clear ADIF bit (PIR1<6>)
 - Set ADIE bit (PIE1<6>)
 - Set PEIE and GIE bits (INTCON<7:6>)
3. Wait the required acquisition time.
4. Start conversion:
 - Set GO/DONE bit (ADCON0<0>)
5. Wait for A/D conversion to complete, by either:
 - Polling for the GO/DONE bit to be cleared (with interrupts disabled); OR
 - Waiting for the A/D interrupt
6. Read A/D Result register pair (ADRESH:ADRESL), clear bit ADIF if required.
7. For next conversion, go to step 1 or step 2 as required. The A/D conversion time per bit is defined as TAD. A minimum wait of 2 TAD is required before the next acquisition starts.

EXAMPLE 9-1: A/D CONVERSION

```

;This code block configures the A/D
;for polling, Vdd reference, R/C clock
;and RA0 input.
;
;Conversion start & wait for complete
;polling code included.
;
BSF    STATUS,RP0      ;Bank 1
MOVLW  B'01110000'    ;A/D RC clock
MOVWF  ADCON1
BSF    TRISA,0        ;Set RA0 to input
BSF    ANSEL,0        ;Set RA0 to analog
BCF    STATUS,RP0     ;Bank 0
MOVLW  B'10000001'    ;Right, Vdd Vref, AN0
MOVWF  ADCON0
CALL   SampleTime     ;Wait min sample time
BSF    ADCON0,GO      ;Start conversion
BTFS   ADCON0,GO      ;Is conversion done?
GOTO   $-1            ;No, test again
MOVF   ADRESH,W       ;Read upper 2 bits
MOVWF  RESULTHI
BSF    STATUS,RP0     ;Bank 1
MOVF   ADRESL,W       ;Read lower 8 bits
MOVWF  RESULTLO
    
```

PIC16F684

9.2 A/D Acquisition Requirements

For the A/D converter to meet its specified accuracy, the charge holding capacitor (CHOLD) must be allowed to fully charge to the input channel voltage level. The analog input model is shown in Figure 9-4. The source impedance (R_S) and the internal sampling switch (R_{SS}) impedance directly affect the time required to charge the capacitor CHOLD. The sampling switch (R_{SS}) impedance varies over the device voltage (V_{DD}), see Figure 9-4. **The maximum recommended impedance for analog sources is 10 k Ω .** As the impedance is decreased, the acquisition time may be decreased.

After the analog input channel is selected (changed), this acquisition must be done before the conversion can be started.

To calculate the minimum acquisition time, Equation 9-1 may be used. This equation assumes that 1/2 LSB error is used (1024 steps for the A/D). The 1/2 LSB error is the maximum error allowed for the A/D to meet its specified resolution.

To calculate the minimum acquisition time, T_{ACQ} , see the "PICmicro® Mid-Range MCU Family Reference Manual" (DS33023).

EQUATION 9-1: ACQUISITION TIME

$$T_{ACQ} = \text{Amplifier Settling Time} + \text{Hold Capacitor Charging Time} + \text{Temperature Coefficient}$$

$$= T_{AMP} + T_C + T_{COFF}$$

$$= 2 \mu\text{s} + T_C + [(Temperature - 25^\circ\text{C})(0.05 \mu\text{s}/^\circ\text{C})]$$

$$T_C = CHOLD (R_{IC} + R_{SS} + R_S) \ln(1/2047)$$

$$= -120 \text{ pF} (1 \text{ k}\Omega + 7 \text{ k}\Omega + 10 \text{ k}\Omega) \ln(0.0004885)$$

$$= 16.47 \mu\text{s}$$

$$T_{ACQ} = 2 \mu\text{s} + 16.47 \mu\text{s} + [(50^\circ\text{C} - 25^\circ\text{C})(0.05 \mu\text{s}/^\circ\text{C})]$$

$$= 19.72 \mu\text{s}$$

Note 1: The reference voltage (V_{REF}) has no effect on the equation, since it cancels itself out.

2: The charge holding capacitor (CHOLD) is not discharged after each conversion.

3: The maximum recommended impedance for analog sources is 10 k Ω . This is required to meet the pin leakage specification.

FIGURE 9-4: ANALOG INPUT MODEL

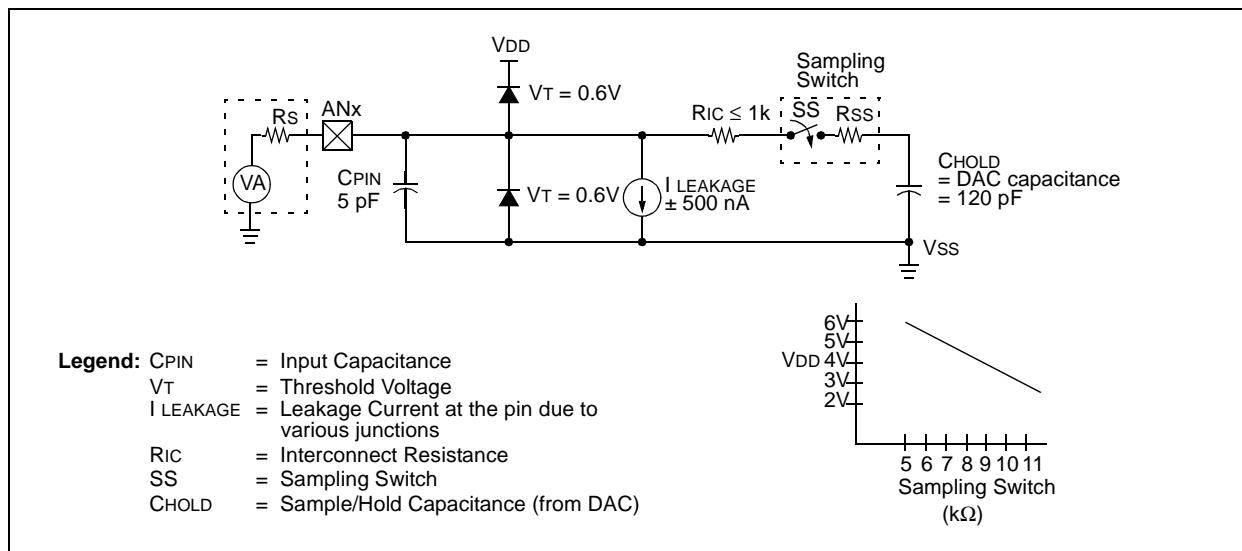

9.3 A/D Operation During Sleep

The A/D converter module can operate during Sleep. This requires the A/D clock source to be set to the internal oscillator. When the RC clock source is selected, the A/D waits one instruction before starting the conversion. This allows the `SLEEP` instruction to be executed, thus eliminating much of the switching noise from the conversion. When the conversion is complete, the `GO/DONE` bit is cleared and the result is loaded into the `ADRESH:ADRESL` registers.

If the A/D interrupt is enabled, the device awakens from Sleep. If the `GIE` bit (`INTCON<7>`) is set, the program counter is set to the interrupt vector (0004h), if `GIE` is clear, the next instruction is executed. If the A/D interrupt is not enabled, the A/D module is turned off, although the `ADON` bit remains set.

When the A/D clock source is something other than RC, a `SLEEP` instruction causes the present conversion to be aborted, and the A/D module is turned off. The `ADON` bit remains set.

FIGURE 9-5: A/D TRANSFER FUNCTION

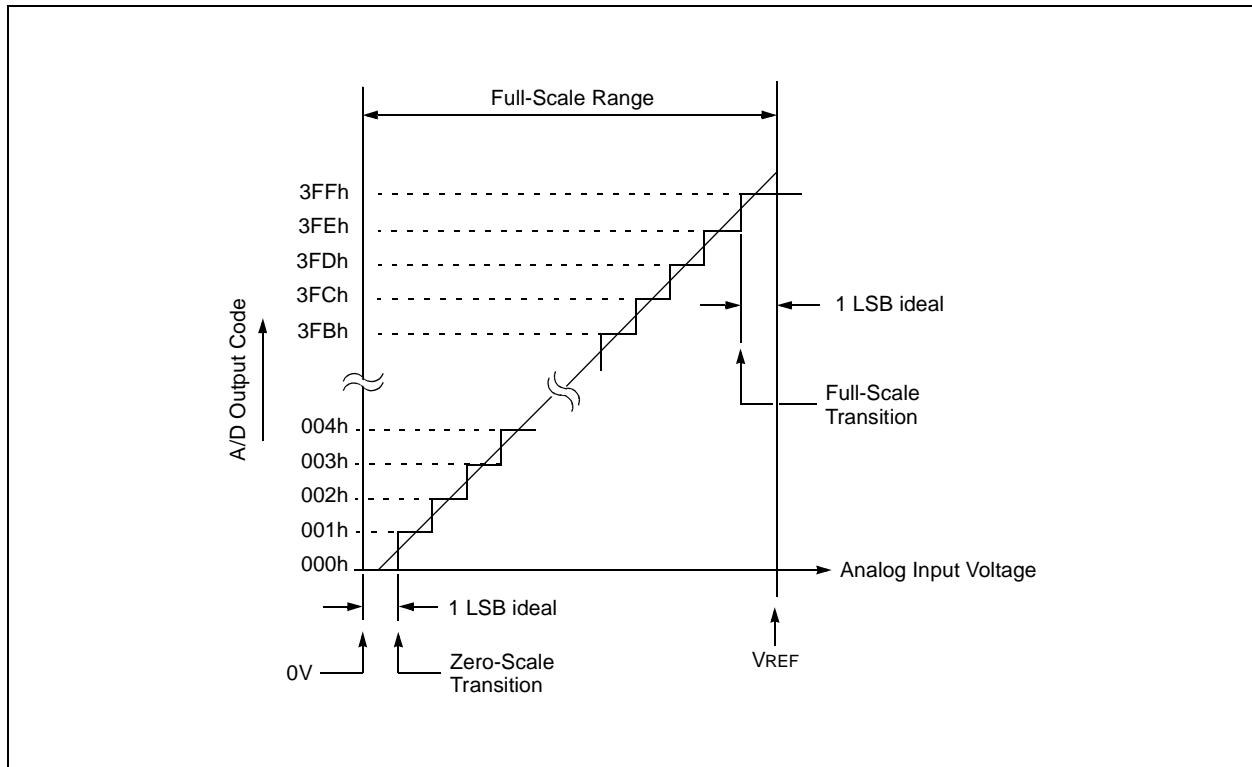

9.4 Effects of Reset

A device Reset forces all registers to their Reset state. Thus, the A/D module is turned off and any pending conversion is aborted. The `ADRESH:ADRESL` registers are unchanged.

9.5 Use of the ECCP Trigger

An A/D conversion can be started by the “special event trigger” of the ECCP module. This requires that the `CCP1M3:CCP1M0` bits (`CCP1CON<3:0>`) be programmed as ‘1011’ and that the A/D module is enabled (`ADON` bit is set). When the trigger occurs, the `GO/DONE` bit will be set, starting the A/D conversion and the `Timer1` counter will be reset to zero. `Timer1` is reset to automatically repeat the A/D acquisition period with minimal software overhead (moving the `ADRESH:ADRESL` to the desired location).

The appropriate analog input channel must be selected and the minimum acquisition done before the “special event trigger” sets the `GO/DONE` bit (starts a conversion).

If the A/D module is not enabled (`ADON` is cleared), then the “special event trigger” will be ignored by the A/D module, but will still reset the `Timer1` counter. See **Section 11.0 “Enhanced Capture/Compare/PWM (ECCP) Module”** for more information.

PIC16F684

TABLE 9-2: SUMMARY OF A/D REGISTERS

Addr	Name	Bit 7	Bit 6	Bit 5	Bit 4	Bit 3	Bit 2	Bit 1	Bit 0	Value on: POR, BOD	Value on all other Resets
05h	PORTA	—	—	RA5	RA4	RA3	RA2	RA1	RA0	--xx xxxx	--uu uuuu
07h	PORTC	—	—	RC5	RC4	RC3	RC2	RC1	RC0	--xx xxxx	--uu uuuu
0Bh/ 8Bh	INTCON	GIE	PEIE	T0IE	INTE	RAIE	T0IF	INTF	RAIF	0000 0000	0000 0000
0Ch	PIR1	EEIF	ADIF	CCP1IF	C2IF	C1IF	OSFIF	TMR2IF	TMR1IF	0000 0000	0000 0000
1Eh	ADRESH	Most Significant 8 bits of the left shifted A/D result or 2 bits of the right shifted result								xxxx xxxx	uuuu uuuu
1Fh	ADCON0	ADFM	VCFG	—	CHS2	CHS1	CHS0	GO/DONE	ADON	00-0 0000	00-0 0000
85h	TRISA	—	—	TRISA5	TRISA4	TRISA3	TRISA2	TRISA1	TRISA0	--11 1111	--11 1111
87h	TRISC	—	—	TRISC5	TRISC4	TRISC3	TRISC2	TRISC1	TRISC0	--11 1111	--11 1111
8Ch	PIE1	EEIE	ADIE	CCP1IE	C2IE	C1IE	OSFIE	TMR2IE	TMR1IE	0000 0000	0000 0000
91h	ANSEL	ANS7	ANS6	ANS5	ANS4	ANS3	ANS2	ANS1	ANS0	1111 1111	1111 1111
9Eh	ADRESL	Least Significant 2 bits of the left shifted A/D result or 8 bits of the right shifted result								xxxx xxxx	uuuu uuuu
9Fh	ADCON1	—	ADCS2	ADCS1	ADCS0	—	—	—	—	-000 ----	-000 ----

Legend: x = unknown, u = unchanged, — = unimplemented read as '0'. Shaded cells are not used for A/D module.

10.0 DATA EEPROM MEMORY

The EEPROM data memory is readable and writable during normal operation (full VDD range). This memory is not directly mapped in the register file space. Instead, it is indirectly addressed through the Special Function Registers. There are four SFRs used to read and write this memory:

- EECON1
- EECON2 (not a physically implemented register)
- EEDAT
- EEADR

EEDAT holds the 8-bit data for read/write, and EEADR holds the address of the EEPROM location being accessed. PIC16F684 has 256 bytes of data EEPROM with an address range from 0h to FFh.

The EEPROM data memory allows byte read and write. A byte write automatically erases the location and writes the new data (erase before write). The EEPROM data memory is rated for high erase/write cycles. The write time is controlled by an on-chip timer. The write time will vary with voltage and temperature as well as from chip-to-chip. Please refer to AC Specifications in **Section 15.0 “Electrical Specifications”** for exact limits.

When the data memory is code-protected, the CPU may continue to read and write the data EEPROM memory. The device programmer can no longer access the data EEPROM data and will read zeroes.

Additional information on the data EEPROM is available in the “PICmicro® Mid-Range MCU Family Reference Manual” (DS33023).

REGISTER 10-1: EEDAT – EEPROM DATA REGISTER (ADDRESS: 9Ah)

R/W-0	R/W-0	R/W-0	R/W-0	R/W-0	R/W-0	R/W-0	R/W-0
EEDAT7	EEDAT6	EEDAT5	EEDAT4	EEDAT3	EEDAT2	EEDAT1	EEDAT0
bit 7							bit 0

bit 7-0 **EEDATn**: Byte Value to Write to or Read From Data EEPROM bits

Legend:

R = Readable bit W = Writable bit U = Unimplemented bit, read as '0'
 -n = Value at POR '1' = Bit is set '0' = Bit is cleared x = Bit is unknown

REGISTER 10-2: EEADR – EEPROM ADDRESS REGISTER (ADDRESS: 9Bh)

R/W-0	R/W-0	R/W-0	R/W-0	R/W-0	R/W-0	R/W-0	R/W-0
EEADR7	EEADR6	EEADR5	EEADR4	EEADR3	EEADR2	EEADR1	EEADR0
bit 7							bit 0

bit 7-0 **EEADR**: Specifies One of 256 Locations for EEPROM Read/Write Operation bits

Legend:

R = Readable bit W = Writable bit U = Unimplemented bit, read as '0'
 -n = Value at POR '1' = Bit is set '0' = Bit is cleared x = Bit is unknown

PIC16F684

10.1 EECON1 and EECON2 Registers

EECON1 is the control register with four low-order bits physically implemented. The upper four bits are non-implemented and read as '0's.

Control bits RD and WR initiate read and write, respectively. These bits cannot be cleared, only set in software. They are cleared in hardware at completion of the read or write operation. The inability to clear the WR bit in software prevents the accidental, premature termination of a write operation.

The WREN bit, when set, will allow a write operation. On power-up, the WREN bit is clear. The WRERR bit is set when a write operation is interrupted by a MCLR Reset, or a WDT Time-out Reset during normal operation. In these situations, following Reset, the user

can check the WRERR bit, clear it and rewrite the location. The data and address will be cleared. Therefore, the EEDAT and EEADR registers will need to be re-initialized.

Interrupt flag, EEIF bit (PIR1<7>), is set when write is complete. This bit must be cleared in software.

EECON2 is not a physical register. Reading EECON2 will read all '0's. The EECON2 register is used exclusively in the data EEPROM write sequence.

Note: The EECON1, EEDAT and EEADR registers should not be modified during a data EEPROM write (WR bit = 1).

REGISTER 10-3: EECON1 – EEPROM CONTROL REGISTER (ADDRESS: 9Ch)

U-0	U-0	U-0	U-0	R/W-x	R/W-0	R/S-0	R/S-0
bit 7	—	—	—	—	WRERR	WREN	WR
							RD
							bit 0

- bit 7-4 **Unimplemented:** Read as '0'
- bit 3 **WRERR:** EEPROM Error Flag bit
 1 = A write operation is prematurely terminated (any MCLR Reset, any WDT Reset during normal operation or BOD detect)
 0 = The write operation completed
- bit 2 **WREN:** EEPROM Write Enable bit
 1 = Allows write cycles
 0 = Inhibits write to the data EEPROM
- bit 1 **WR:** Write Control bit
 1 = Initiates a write cycle (The bit is cleared by hardware once write is complete. The WR bit can only be set, not cleared, in software.)
 0 = Write cycle to the data EEPROM is complete
- bit 0 **RD:** Read Control bit
 1 = Initiates an EEPROM read (Read takes one cycle. RD is cleared in hardware. The RD bit can only be set, not cleared, in software.)
 0 = Does not initiate an EEPROM read

Legend:
 S = Bit can only be set
 R = Readable bit W = Writable bit U = Unimplemented bit, read as '0'
 -n = Value at POR '1' = Bit is set '0' = Bit is cleared x = Bit is unknown

10.2 Reading the EEPROM Data Memory

To read a data memory location, the user must write the address to the EEADR register and then set control bit RD (EECON1<0>), as shown in Example 10-1. The data is available, in the very next cycle, in the EEDAT register. Therefore, it can be read in the next instruction. EEDAT holds this value until another read, or until it is written to by the user (during a write operation).

EXAMPLE 10-1: DATA EEPROM READ

```
BSF      STATUS,RP0 ;Bank 1
MOVLW   CONFIG_ADDR ;
MOVWF   EEADR      ;Address to read
BSF     EECON1,RD  ;EE Read
MOVF    EEDAT,W    ;Move data to W
```

10.3 Writing to the EEPROM Data Memory

To write an EEPROM data location, the user must first write the address to the EEADR register and the data to the EEDAT register. Then the user must follow a specific sequence to initiate the write for each byte, as shown in Example 10-2.

EXAMPLE 10-2: DATA EEPROM WRITE

```
BSF      STATUS,RP0 ;Bank 1
BSF     EECON1,WREN ;Enable write
BCF     INTCON,GIE  ;Disable INTs
MOVLW   55h         ;Unlock write
MOVWF   EECON2      ;
MOVLW   AAh         ;
MOVWF   EECON2      ;
BSF     EECON1,WR   ;Start the write
BSF     INTCON,GIE  ;Enable INTS
```

The write will not initiate if the above sequence is not exactly followed (write 55h to EECON2, write AAh to EECON2, then set WR bit) for each byte. We strongly recommend that interrupts be disabled during this code segment. A cycle count is executed during the required sequence. Any number that is not equal to the required cycles to execute the required sequence will prevent the data from being written into the EEPROM.

Additionally, the WREN bit in EECON1 must be set to enable write. This mechanism prevents accidental writes to data EEPROM due to errant (unexpected) code execution (i.e., lost programs). The user should keep the WREN bit clear at all times, except when updating EEPROM. The WREN bit is not cleared by hardware.

After a write sequence has been initiated, clearing the WREN bit will not affect this write cycle. The WR bit will be inhibited from being set unless the WREN bit is set.

At the completion of the write cycle, the WR bit is cleared in hardware and the EE Write Complete Interrupt Flag bit (EEIF) is set. The user can either enable this interrupt or poll this bit. The EEIF bit (PIR1<7>) register must be cleared by software.

10.4 Write Verify

Depending on the application, good programming practice may dictate that the value written to the data EEPROM should be verified (see Example 10-3) to the desired value to be written.

EXAMPLE 10-3: WRITE VERIFY

```
BSF      STATUS,RP0 ;Bank 1
MOVF    EEDAT,W    ;EEDAT not changed
                    ;from previous write
BSF     EECON1,RD  ;YES, Read the
                    ;value written
XORWF   EEDAT,W    ;
BTFS    STATUS,Z   ;Is data the same
GOTO    WRITE_ERR  ;No, handle error
:       ;Yes, continue
```

10.4.1 USING THE DATA EEPROM

The data EEPROM is a high-endurance, byte addressable array that has been optimized for the storage of frequently changing information. The maximum endurance for any EEPROM cell is specified as Dxxx. D120 or D120A specify a maximum number of writes to any EEPROM location before a refresh is required of infrequently changing memory locations.

10.4.2 EEPROM ENDURANCE

A hypothetical data EEPROM is 64 bytes long and has an endurance of 1M writes. It also has a refresh parameter of 10M writes. If every memory location in the cell were written the maximum number of times, the data EEPROM would fail after 64M write cycles. If every memory location save one were written the maximum number of times, the data EEPROM would fail after 63M write cycles, but the one remaining location could fail after 10M cycles. If proper refreshes occurred, then the lone memory location would have to be refreshed six times for the data to remain correct.

PIC16F684

10.5 Protection Against Spurious Write

There are conditions when the user may not want to write to the data EEPROM memory. To protect against spurious EEPROM writes, various mechanisms have been built in. On power-up, WREN is cleared. Also, the Power-up Timer (64 ms duration) prevents EEPROM write.

The write initiate sequence and the WREN bit together help prevent an accidental write during:

- Brown-out
- Power Glitch
- Software Malfunction

10.6 Data EEPROM Operation During Code-Protect

Data memory can be code-protected by programming the CPD bit in the Configuration Word register (Register 12-1) to '0'.

When the data memory is code-protected, the CPU is able to read and write data to the data EEPROM. It is recommended to code-protect the program memory when code-protecting data memory. This prevents anyone from programming zeroes over the existing code (which will execute as NOPs) to reach an added routine, programmed in unused program memory, which outputs the contents of data memory. Programming unused locations in program memory to '0' will also help prevent data memory code protection from becoming breached.

TABLE 10-1: REGISTERS/BITS ASSOCIATED WITH DATA EEPROM

Address	Name	Bit 7	Bit 6	Bit 5	Bit 4	Bit 3	Bit 2	Bit 1	Bit 0	Value on POR, BOD	Value on all other Resets
0Bh/8Bh	INTCON	GIE	PEIE	T0IE	INTE	RAIE	T0IF	INTF	RAIF	0000 0000	0000 0000
0Ch	PIR1	EEIF	ADIF	CCP1IF	C2IF	C1IF	OSFIF	TMR2IF	TMR1IF	0000 0000	0000 0000
8Ch	PIE1	EEIE	ADIE	CCP1IE	C2IE	C1IE	OSFIE	TMR2IE	TMR1IE	0000 0000	0000 0000
9Ah	EEDAT	EEDAT7	EEDAT6	EEDAT5	EEDAT4	EEDAT3	EEDAT2	EEDAT1	EEDAT0	0000 0000	0000 0000
9Bh	EEADR	EEADR7	EEADR6	EEADR5	EEADR	EEADR	EEADR	EEADR	EEADR	0000 0000	0000 0000
9Ch	EECON1	—	—	—	—	WRERR	WREN	WR	RD	---- x000	---- q000
9Dh	EECON2 ⁽¹⁾	EEPROM Control register 2								---- ----	---- ----

Legend: x = unknown, u = unchanged, — = unimplemented read as '0', q = value depends upon condition. Shaded cells are not used by data EEPROM module.

Note 1: EECON2 is not a physical register.

11.0 ENHANCED CAPTURE/COMPARE/PWM (ECCP) MODULE

The enhanced Capture/Compare/PWM (ECCP) module contains a 16-bit register which can operate as a:

- 16-bit Capture register
- 16-bit Compare register
- PWM Master/Slave Duty Cycle register

Capture/Compare/PWM Register 1 (CCPR1) is comprised of two 8-bit registers: CCPR1L (low byte) and CCPR1H (high byte).

The CCP1CON register controls the operation of ECCP. The special event trigger is generated by a compare match and will clear both TMR1H and TMR1L registers.

TABLE 11-1: ECCP MODE – TIMER RESOURCES REQUIRED

ECCP Mode	Timer Resource
Capture	Timer1
Compare	Timer1
PWM	Timer2

REGISTER 11-1: CCP1CON — ENHANCED CCP OPERATION REGISTER (ADDRESS: 15h)

R/W-0	R/W-0	R/W-0	R/W-0	R/W-0	R/W-0	R/W-0	R/W-0	
P1M1	P1M0	DC1B1	DC1B0	CCP1M3	CCP1M2	CCP1M1	CCP1M0	
bit 7								bit 0

bit 7-6 **P1M<1:0>**: PWM Output Configuration bits

If CCP1M<3:2> = 00, 01, 10:

xx = P1A assigned as Capture/Compare input; P1B, P1C, P1D assigned as port pins

If CCP1M<3:2> = 11:

00 = Single output; P1A modulated; P1B, P1C, P1D assigned as port pins

01 = Full-bridge output forward; P1D modulated; P1A active; P1B, P1C inactive

10 = Half-bridge output; P1A, P1B modulated with dead band control; P1C, P1D assigned as port pins

11 = Full-bridge output reverse; P1B modulated; P1C active; P1A, P1D inactive

bit 5-4 **DC1B<1:0>**: PWM Duty Cycle Least Significant bits

Capture mode:

Unused.

Compare mode:

Unused.

PWM mode:

These bits are the two LSBs of the PWM duty cycle. The eight MSBs are found in CCPR1L.

bit 3-0 **CCP1M<3:0>**: ECCP Mode Select bits

0000 = Capture/Compare/PWM off (resets ECCP module)

0001 = Unused (reserved)

0010 = Compare mode, toggle output on match (CCP1IF bit is set)

0011 = Unused (reserved)

0100 = Capture mode, every falling edge

0101 = Capture mode, every rising edge

0110 = Capture mode, every 4th rising edge

0111 = Capture mode, every 16th rising edge

1000 = Compare mode, set output on match (CCP1IF bit is set)

1001 = Compare mode, clear output on match (CCP1IF bit is set)

1010 = Compare mode, generate software interrupt on match (CCP1IF bit is set, CCP1 pin is unaffected)

1011 = Compare mode, trigger special event (CCP1IF bit is set; CCP1 resets TMR1or TMR2, and starts an A/D conversion, if the A/D module is enabled)

1100 = PWM mode; P1A, P1C active-high; P1B, P1D active-high

1101 = PWM mode; P1A, P1C active-high; P1B, P1D active-low

1110 = PWM mode; P1A, P1C active-low; P1B, P1D active-high

1111 = PWM mode; P1A, P1C active-low; P1B, P1D active-low

Legend:

R = Readable bit

W = Writable bit

U = Unimplemented bit, read as '0'

-n = Value at POR

'1' = Bit is set

'0' = Bit is cleared

x = Bit is unknown

PIC16F684

11.1 Capture Mode

In Capture mode, CCP1H:CCP1L captures the 16-bit value of the TMR1 register when an event occurs on pin RC5/CCP1/P1A. An event is defined as one of the following and is configured by CCP1CON<3:0>:

- Every falling edge
- Every rising edge
- Every 4th rising edge
- Every 16th rising edge

When a capture is made, the interrupt request flag bit, CCP1IF (PIR1<5>), is set. The interrupt flag must be cleared in software. If another capture occurs before the value in register CCP1 is read, the old captured value is overwritten by the new captured value.

11.1.1 CCP1 PIN CONFIGURATION

In Capture mode, the RC5/CCP1/P1A pin should be configured as an input by setting the TRISC<5> bit.

Note: If the RC5/CCP1/P1A pin is configured as an output, a write to the port can cause a capture condition.

11.1.4 ECCP PRESCALER

There are four prescaler settings specified by bits CCP1M<3:0> (CCP1CON<3:0>). Whenever the ECCP module is turned off, or the ECCP module is not in Capture mode, the prescaler counter is cleared. Any Reset will clear the prescaler counter.

Switching from one capture prescaler to another may generate an interrupt. Also, the prescaler counter will not be cleared; therefore, the first capture may be from a non-zero prescaler. Example 11-1 shows the recommended method for switching between capture prescalers. This example also clears the prescaler counter and will not generate the "false" interrupt.

EXAMPLE 11-1: CHANGING BETWEEN CAPTURE PRESCALERS

```
CLRF    CCP1CON    ;Turn ECCP module off
MOVLW  NEW_CAPT_PS ;Load the W reg with
                    ;the new prescaler
                    ;move value and ECCP ON
MOVWF  CCP1CON    ;Load CCP1CON with this
                    ;value
```

FIGURE 11-1: CAPTURE MODE OPERATION BLOCK DIAGRAM

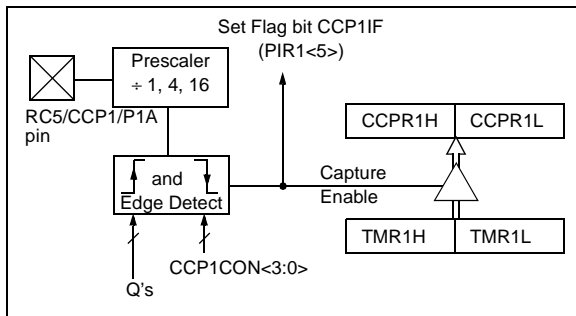

11.1.2 TIMER1 MODE SELECTION

Timer1 must be running in Timer mode or Synchronized Counter mode for the ECCP module to use the capture feature. In Asynchronous Counter mode, the capture operation may not work.

11.1.3 SOFTWARE INTERRUPT

When the Capture mode is changed, a false capture interrupt may be generated. The user should keep bit CCP1IE (PIE1<5>) clear to avoid false interrupts and should clear the flag bit CCP1IF (PIR1<5>) following any such change in operating mode.

11.2 Compare Mode

In Compare mode, the 16-bit CCPR1 register value is constantly compared against the TMR1 register pair value. When a match occurs, the RC5/CCP1/P1A pin is:

- Driven high
- Driven low
- Remains unchanged

The action on the pin is based on the value of control bits, CCP1M<3:0> (CCP1CON<3:0>). At the same time, interrupt flag bit, CCP1IF (PIR1<5>), is set.

FIGURE 11-2: COMPARE MODE OPERATION BLOCK DIAGRAM

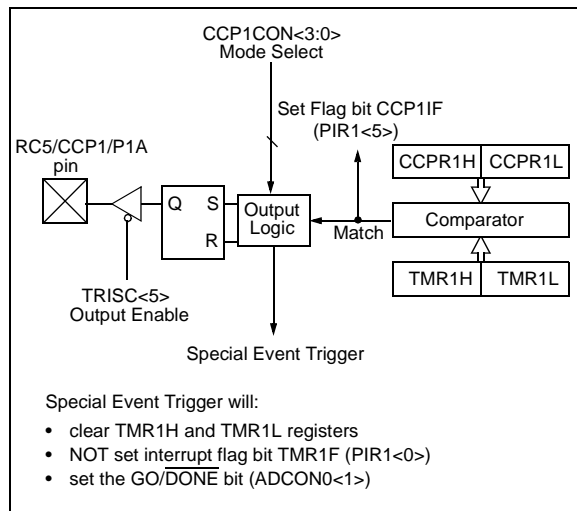

11.2.1 CCP1 PIN CONFIGURATION

The user must configure the RC5/CCP1/P1A pin as an output by clearing the TRISC<5> bit.

Note: Clearing the CCP1CON register will force the RC5/CCP1/P1A compare output latch to the default low level. This is not the PORTC I/O data latch.

11.2.2 TIMER1 MODE SELECTION

Timer1 must be running in Timer mode or Synchronized Counter mode if the ECCP module is using the compare feature. In Asynchronous Counter mode, the compare operation may not work.

11.2.3 SOFTWARE INTERRUPT MODE

When Generate Software Interrupt mode is chosen (CCP1M<3:0> = 1010), the CCP1 pin is not affected. The CCP1IF (PIR1<5>) bit is set, causing a ECCP interrupt (if enabled). See Register 11-1.

11.2.4 SPECIAL EVENT TRIGGER

In this mode (CCP1M<3:0> = 1011), an internal hardware trigger is generated, which may be used to initiate an action. See Register 11-1.

The special event trigger output of ECCP resets the TMR1 register pair. This allows the CCPR1 register to effectively be a 16-bit programmable period register for Timer1. The special event trigger output also starts an A/D conversion (if the A/D module is enabled).

Note: The special event trigger from the ECCP module will not set interrupt flag bit TMR1IF (PIR1<0>).

TABLE 11-2: REGISTERS ASSOCIATED WITH CAPTURE, COMPARE, AND TIMER1

Addr	Name	Bit 7	Bit 6	Bit 5	Bit 4	Bit 3	Bit 2	Bit 1	Bit 0	Value on POR, BOD	Value on all other Resets
0Bh/8Bh	INTCON	GIE	PEIE	TOIE	INTE	RAIE	T0IF	INTF	RAIF	0000 0000	0000 0000
0Ch	PIR1	EEIF	ADIF	CCP1IF	C2IF	C1IF	OSFIF	TMR2IF	TMR1IF	0000 0000	0000 0000
0Eh	TMR1L	Holding register for the Least Significant Byte of the 16-bit TMR1 register								xxxx xxxx	uuuu uuuu
0Fh	TMR1H	Holding register for the Most Significant Byte of the 16-bit TMR1 register								xxxx xxxx	uuuu uuuu
10h	T1CON	T1GINV	TMR1GE	T1CKPS1	T1CKPS0	T1OSCEN	T1SYNC	TMR1CS	TMR1ON	0000 0000	uuuu uuuu
1Ah	CMCON1	—	—	—	—	—	—	T1GSS	C2SYNC	---- --10	---- --10
13h	CCPR1L	Capture/Compare/PWM Register 1 Low Byte								xxxx xxxx	uuuu uuuu
14h	CCPR1H	Capture/Compare/PWM Register 1 High Byte								xxxx xxxx	uuuu uuuu
15h	CCP1CON	P1M1	P1M0	DC1B1	DC1B0	CCP1M3	CCP1M2	CCP1M1	CCP1M0	0000 0000	0000 0000
87h	TRISC	—	—	TRISC5	TRISC4	TRISC3	TRISC2	TRISC1	TRISC0	--11 1111	--11 1111
8Ch	PIE1	EEIE	ADIE	CCP1IE	C2IE	C1IE	OSFIE	TMR2IE	TMR1IE	0000 0000	0000 0000

Legend: — = Unimplemented locations, read as '0', u = unchanged, x = unknown. Shaded cells are not used by the Capture, Compare or Timer1 module.

PIC16F684

11.3 Enhanced PWM Mode

The Enhanced CCP module produces up to a 10-bit resolution PWM output and may have up to four outputs, depending on the selected operating mode. These outputs, designated P1A through P1D, are multiplexed with I/O pins on PORTC. The pin assignments are summarized in Table 11-3.

Figure 11-3 shows a simplified block diagram of PWM operation.

To configure I/O pins as PWM outputs, the proper PWM mode must be selected by setting the P1M<1:0> and CCP1M<3:0> bits (CCP1CON<7:6> and CCP1CON<3:0>, respectively). The appropriate TRISC bits must also be set as outputs.

FIGURE 11-3: SIMPLIFIED BLOCK DIAGRAM OF THE ENHANCED PWM MODULE

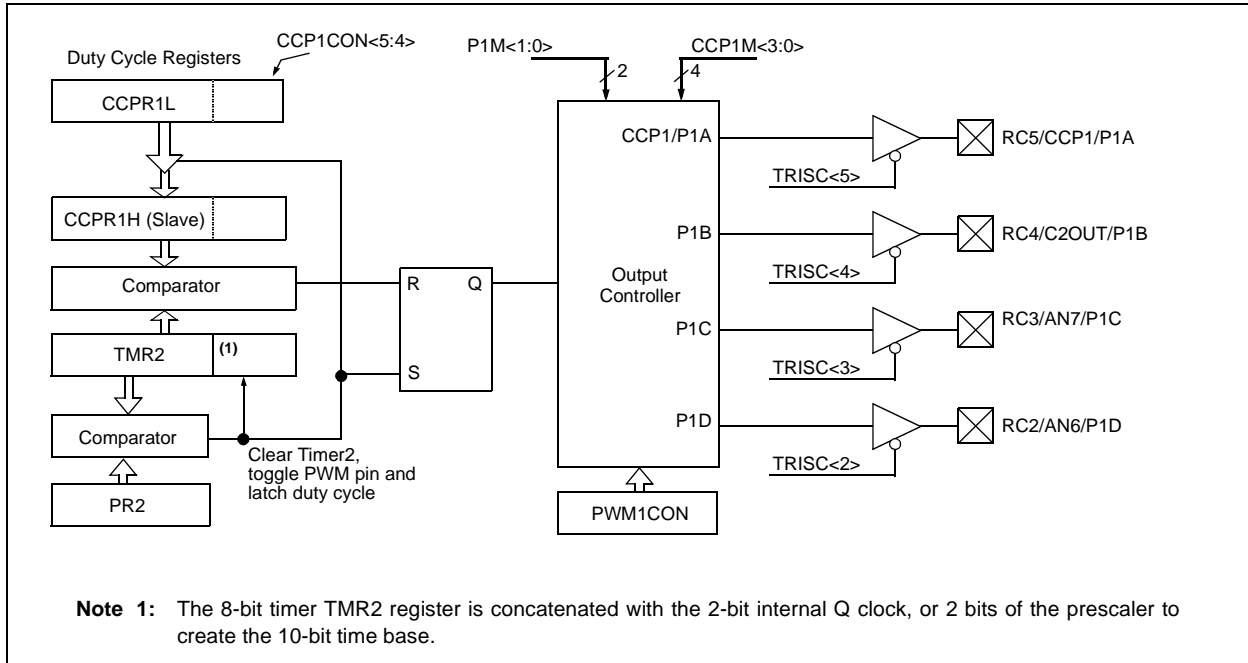

11.3.1 PWM OUTPUT CONFIGURATIONS

The P1M<1:0> bits in the CCP1CON register allows one of four configurations:

- Single Output
- Half-bridge Output
- Full-bridge Output, Forward mode
- Full-bridge Output, Reverse mode

The general relationship of the outputs in all configurations is summarized in Figure 11-3.

Note: Clearing the CCP1CON register will force the PWM output latches to their default inactive levels. This is not the PORTC I/O data latch.

TABLE 11-3: PIN ASSIGNMENTS FOR VARIOUS ENHANCED CCP MODES

ECCP Mode	CCP1CON Configuration	RC5	RC4	RC3	RC2
Compatible CCP	00xx11xx	CCP1	RC4/C2OUT	RC3/AN7	RC2/AN6
Dual PWM	10xx11xx	P1A	P1B	RC3/AN7	RC2/AN6
Quad PWM	x1xx11xx	P1A	P1B	P1C	P1D

Legend: x = Don't care. Shaded cells indicate pin assignments not used by ECCP in a given mode.

Note 1: TRIS register values must be configured appropriately.

2: With ECCP in Dual or Quad PWM mode, the C2OUT output control of PORTC must be disabled.

11.3.2 PWM PERIOD

A PWM output (Figure 11-4 and Figure 11-5) has a time base (period) and a time that the output is active (duty cycle). The PWM period is specified by writing to the PR2 register. The PWM period can be calculated using the following formula:

EQUATION 11-1:

$$PWM\ period = [(PR2) + 1] \cdot 4 \cdot TOSC \cdot (TMR2\ prescale\ value)$$

PWM frequency is defined as $1 / [PWM\ period]$.

When TMR2 is equal to PR2, the following three events occur on the next increment cycle:

- TMR2 is cleared
- The appropriate PWM pin toggles. In Dual PWM mode, this occurs after the dead band delay expires (exception: if PWM duty cycle = 0%, the pin will not be set)
- The PWM duty cycle is latched from CCPR1L into CCPR1H

Note: The Timer2 postscaler (see **Section 7.1 “Timer2 Operation”**) is not used in the determination of the PWM frequency. The postscaler could be used to have a servo update rate at a different frequency than the PWM output.

11.3.3 PWM DUTY CYCLE

The PWM duty cycle is specified by writing to the CCPR1L register and to the DC1B<1:0> (CCP1CON<5:4>) bits. Up to 10 bits of resolution is available. The CCPR1L contains the eight MSBs and the DC1B<1:0> contains the two LSbs. CCPR1L and DC1B<1:0> can be written to at any time. In PWM mode, CCPR1H is a read-only register. This 10-bit value is represented by CCPR1L (CCP1CON<5:4>).

The following equation is used to calculate the PWM duty cycle in time:

EQUATION 11-2:

$$PWM\ duty\ cycle = (CCPR1L:CCP1CON<5:4>) \cdot TOSC \cdot (TMR2\ prescale\ value)$$

When the CCPR1H and 2-bit latch match TMR2, concatenated with an internal 2-bit Q clock or 2 bits of the TMR2 prescaler, the appropriate PWM pin is toggled. In Dual PWM mode, the pin will be toggled after the dead band time has expired.

The polarity (active-high or active-low) and mode of the signal are configured by the P1M<1:0> (CCP1CON<7:6>) and CCP1M<3:0> (CCP1CON<3:0>) bits.

The maximum PWM resolution for a given PWM frequency is given by the formula:

EQUATION 11-3:

$$Resolution = \frac{\log\left(\frac{FOSC}{FPWM \cdot TMR2\ Prescaler}\right)}{\log(2)} \text{ bits}$$

All control registers are double buffered and are loaded at the beginning of a new PWM cycle (the period boundary when Timer2 resets) in order to prevent glitches on any of the outputs. The exception is the PWM delay register, which is loaded at either the duty cycle boundary or the period boundary (whichever comes first). Because of the buffering, the module waits until the timer resets, instead of starting immediately. This means that enhanced PWM waveforms do not exactly match the standard PWM waveforms, but are instead offset by one full instruction cycle (4 TOSC).

Note: If the PWM duty cycle value is longer than the PWM period, the assigned PWM pin(s) will remain unchanged.

TABLE 11-4: EXAMPLE PWM FREQUENCIES AND RESOLUTIONS (Fosc = 20 MHz)

PWM Frequency	1.22 kHz ⁽¹⁾	4.88 kHz ⁽¹⁾	19.53 kHz	78.12 kHz	156.3 kHz	208.3 kHz
Timer Prescale (1, 4, 16)	16	4	1	1	1	1
PR2 Value	0xFF	0xFF	0xFF	0x3F	0x1F	0x17
Maximum Resolution (bits)	10	10	10	8	7	6.6

Note 1: Changing duty cycle will cause a glitch.

PIC16F684

FIGURE 11-4: PWM OUTPUT RELATIONSHIPS (ACTIVE-HIGH STATE)

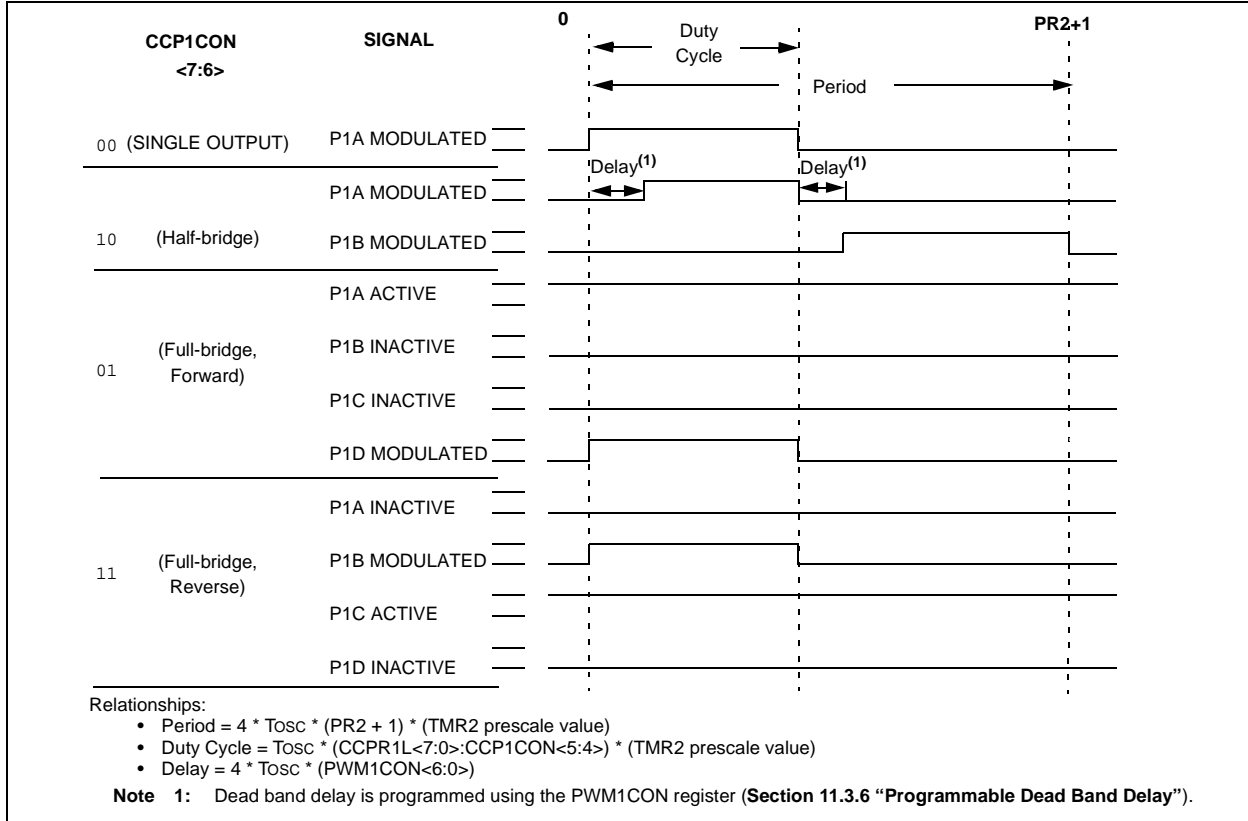
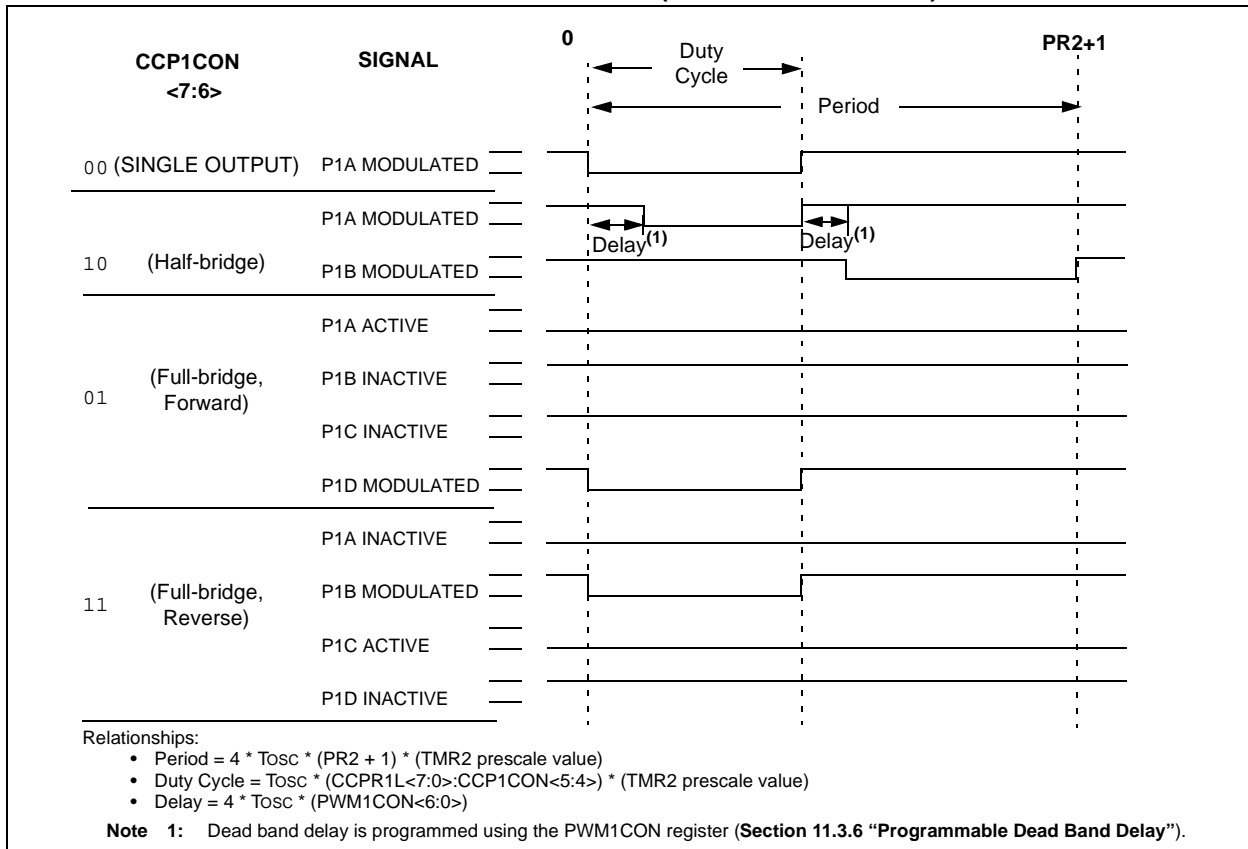

FIGURE 11-5: PWM OUTPUT RELATIONSHIPS (ACTIVE-LOW STATE)



11.3.4 HALF-BRIDGE MODE

In the Half-bridge Output mode, two pins are used as outputs to drive push-pull loads. The PWM output signal is output on the RC5/CCP1/P1A pin, while the complementary PWM output signal is output on the RC4/C2OUT/P1B pin (Figure 11-6). This mode can be used for half-bridge applications, as shown in Figure 11-7, or for full-bridge applications, where four power switches are being modulated with two PWM signals.

In Half-bridge Output mode, the programmable dead band delay can be used to prevent shoot-through current in half-bridge power devices. The value of bits PDC<6:0> (PWM1CON<6:0>) sets the number of instruction cycles before the output is driven active. If the value is greater than the duty cycle, the corresponding output remains inactive during the entire cycle. See **Section 11.3.6 “Programmable Dead Band Delay”** for more details of the dead band delay operations.

Since the P1A and P1B outputs are multiplexed with the PORTC<5:4> data latches, the TRISC<5:4> bits must be cleared to configure P1A and P1B as outputs.

FIGURE 11-6: HALF-BRIDGE PWM OUTPUT

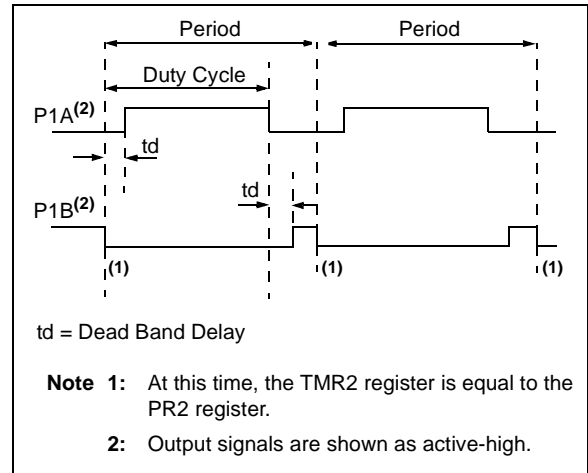
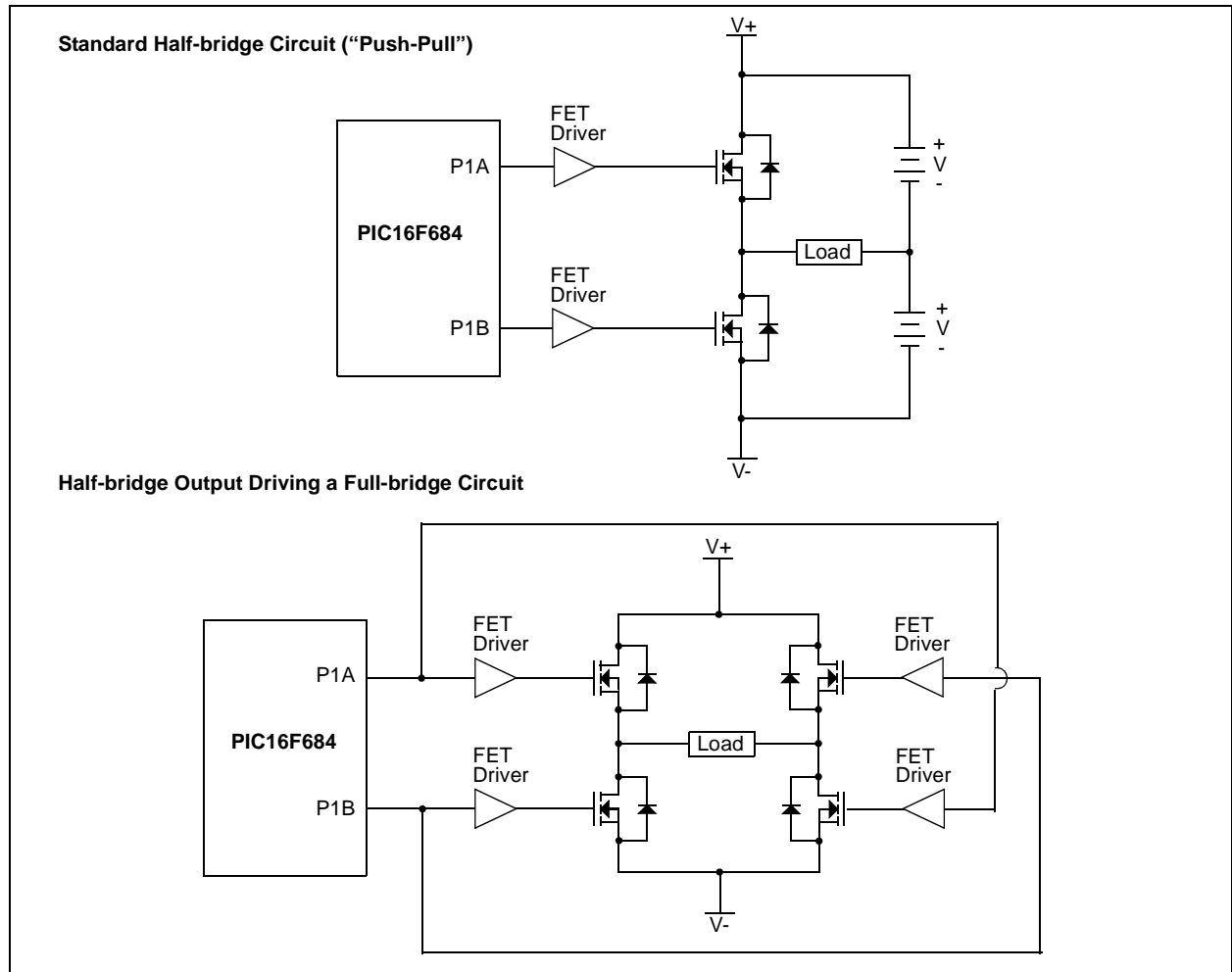

FIGURE 11-7: EXAMPLES OF HALF-BRIDGE APPLICATIONS



PIC16F684

11.3.5 FULL-BRIDGE MODE

In Full-bridge Output mode, four pins are used as outputs; however, only two outputs are active at a time. In the Forward mode, pin RC5/CCP1/P1A is continuously active and pin RC2/AN6/P1D is modulated.

In the Reverse mode, RC3/AN7/P1C pin is continuously active and RC4/C2OUT/P1B pin is modulated. These are illustrated in Figure 11-8.

P1A, P1B, P1C and P1D outputs are multiplexed with the PORTC<5:2> data latches. The TRISC<5:2> bits must be cleared to make the P1A, P1B, P1C and P1D pins output.

FIGURE 11-8: FULL-BRIDGE PWM OUTPUT

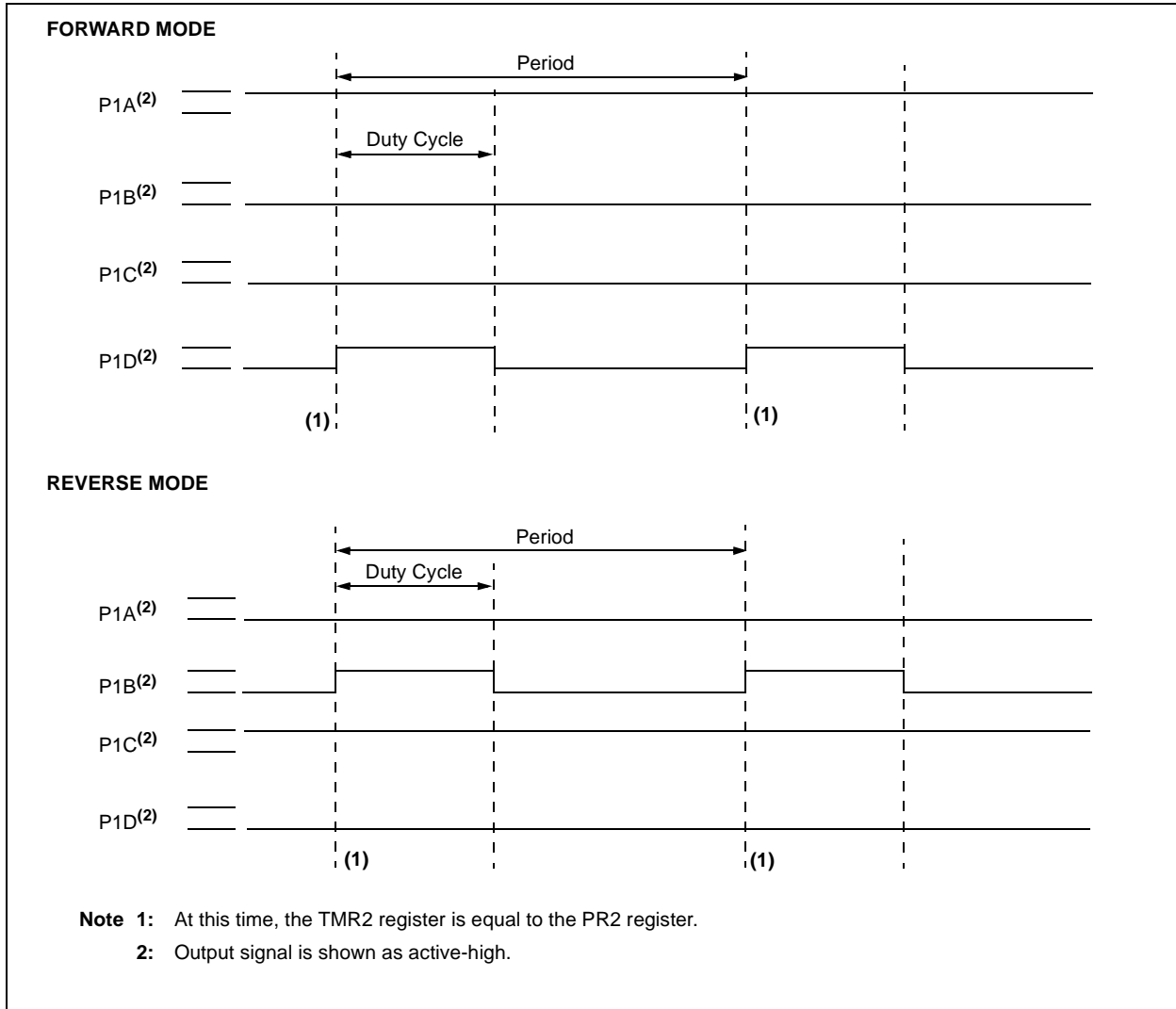
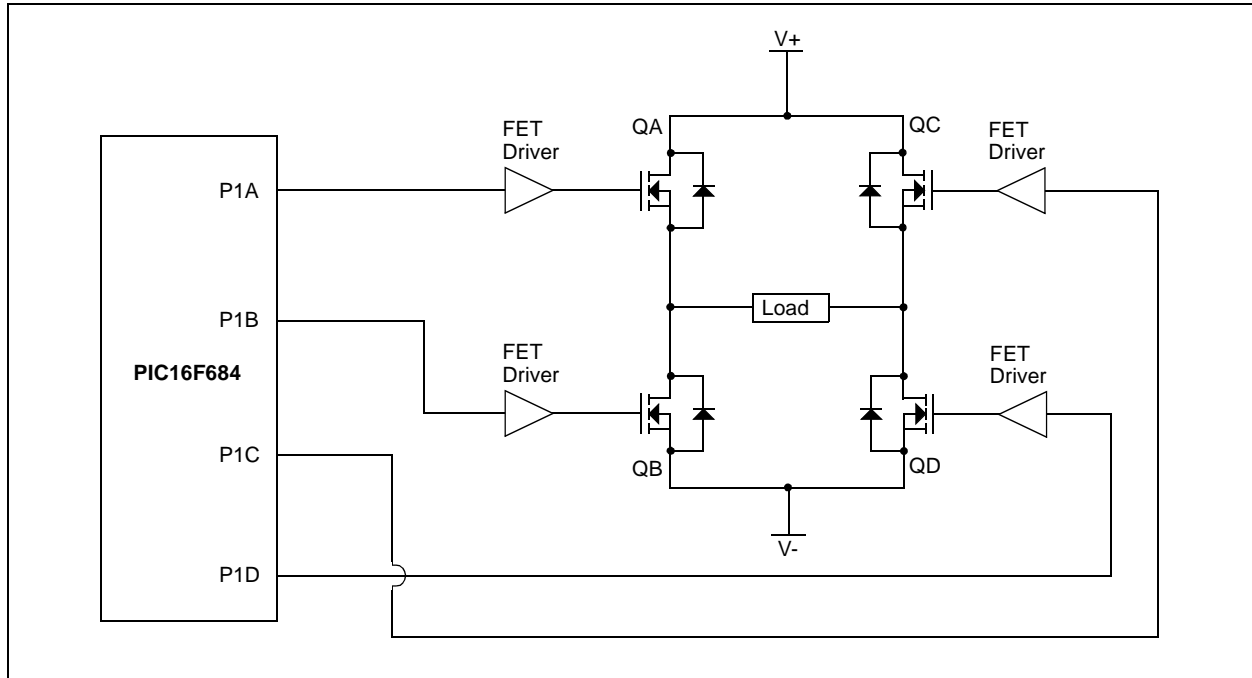

FIGURE 11-9: EXAMPLE OF FULL-BRIDGE APPLICATION



11.3.5.1 Direction Change in Full-Bridge Mode

In the Full-bridge Output mode, the P1M1 bit (CCP1CON<7>) allows user to control the Forward/Reverse direction. When the application firmware changes this direction control bit, the module will assume the new direction on the next PWM cycle.

Just before the end of the current PWM period, the modulated outputs (P1B and P1D) are placed in their inactive state, while the unmodulated outputs (P1A and P1C) are switched to drive in the opposite direction. This occurs in a time interval of $(4 T_{osc} * (\text{Timer2 Prescale value}))$ before the next PWM period begins. The Timer2 prescaler will be either 1, 4 or 16, depending on the value of the T2CKPS<1:0> bits (T2CON<1:0>). During the interval from the switch of the unmodulated outputs to the beginning of the next period, the modulated outputs (P1B and P1D) remain inactive. This relationship is shown in Figure 11-10.

Note that in the Full-bridge Output mode, the ECCP module does not provide any dead band delay. In general, since only one output is modulated at all times, dead band delay is not required. However, there is a situation where a dead band delay might be required. This situation occurs when both of the following conditions are true:

1. The direction of the PWM output changes when the duty cycle of the output is at or near 100%.
2. The turn off time of the power switch, including the power device and driver circuit, is greater than the turn on time.

Figure 11-11 shows an example where the PWM direction changes from forward to reverse, at a near 100% duty cycle. At time t_1 , the output P1A and P1D become inactive, while output P1C becomes active. In this example, since the turn off time of the power devices is longer than the turn on time, a shoot-through current may flow through power devices QC and QD (see Figure 11-9) for the duration of 't'. The same phenomenon will occur to power devices QA and QB for PWM direction change from reverse to forward.

If changing PWM direction at high duty cycle is required for an application, one of the following requirements must be met:

1. Reduce PWM duty cycle for one PWM period before changing directions.
2. Use switch drivers that can drive the switches off faster than they can drive them on.

Other options to prevent shoot-through current may exist.

PIC16F684

FIGURE 11-10: PWM DIRECTION CHANGE

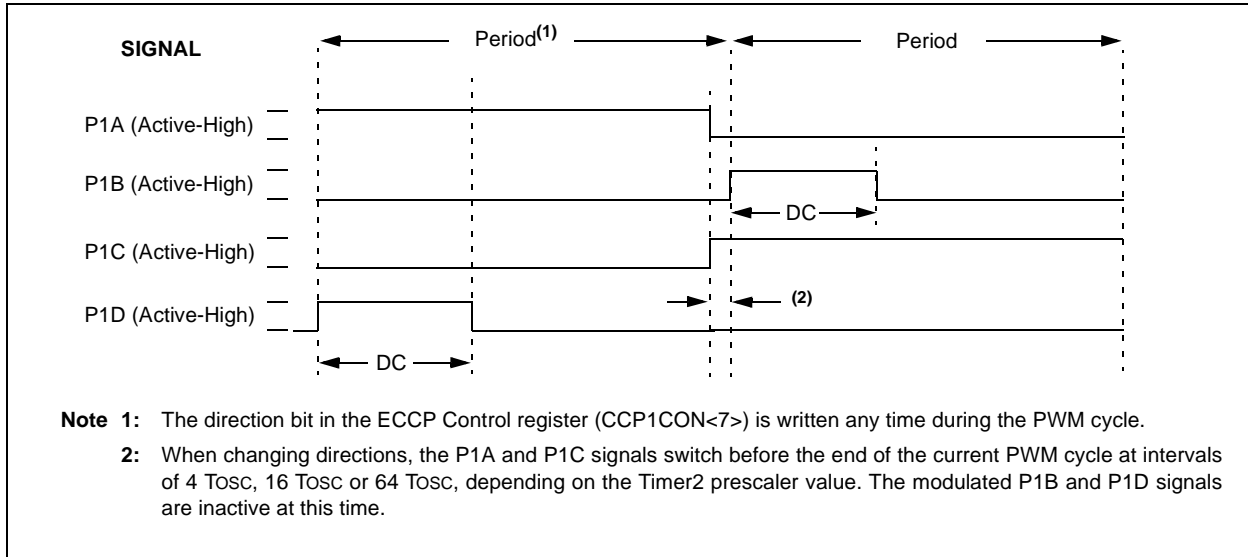
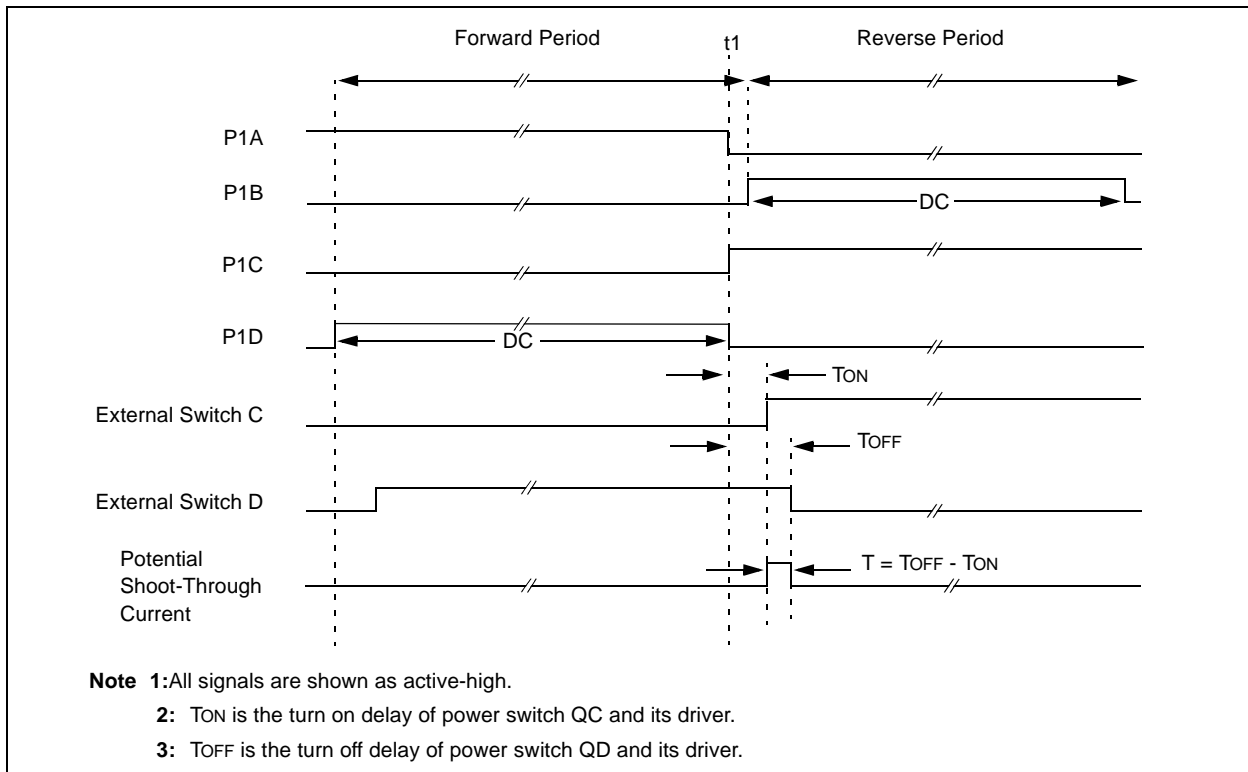

FIGURE 11-11: PWM DIRECTION CHANGE AT NEAR 100% DUTY CYCLE



11.3.6 PROGRAMMABLE DEAD BAND DELAY

In half-bridge applications where all power switches are modulated at the PWM frequency at all times, the power switches normally require more time to turn off than to turn on. If both the upper and lower power switches are switched at the same time (one turned on, and the other turned off), both switches may be on for a short period of time until one switch completely turns off. During this brief interval, a very high current (*shoot-through current*) may flow through both power switches, shorting the bridge supply. To avoid this potentially destructive shoot-through current from flowing during switching, turning on either of the power switches is normally delayed to allow the other switch to completely turn off.

In the Half-bridge Output mode, a digitally programmable dead band delay is available to avoid shoot-through current from destroying the bridge power switches. The delay occurs at the signal transition from the non-active state to the active state. See Figure 11-6 for illustration. The lower seven bits of the PWM1CON register (Register 11-2) sets the delay period in terms of microcontroller instruction cycles (TCY or 4 TOSC).

11.3.7 ENHANCED PWM AUTO-SHUTDOWN

When the ECCP is programmed for any of the enhanced PWM modes, the active output pins may be configured for auto-shutdown. Auto-shutdown immediately places the enhanced PWM output pins into a defined shutdown state when a shutdown event occurs.

A shutdown event can be caused by either of the two comparators or the INT pin (or any combination of these three sources). The comparators may be used to monitor a voltage input proportional to a current being monitored in the bridge circuit. If the voltage exceeds a threshold, the comparator switches state and triggers a shutdown. Alternatively, a digital signal on the INT pin can also trigger a shutdown. The auto-shutdown feature can be disabled by not selecting any auto-shutdown sources. The auto-shutdown sources to be used are selected using the ECCPAS<2:0> bits (ECCPAS<6:4>).

When a shutdown occurs, the output pins are asynchronously placed in their shutdown states, specified by the PSSAC<1:0> and PSSBD<1:0> bits (ECCPAS<3:0>). Each pin pair (P1A/P1C and P1B/P1D) may be set to drive high, drive low, or be tri-stated (not driving). The ECCPASE bit (ECCPAS<7>) is also set to hold the enhanced PWM outputs in their shutdown states.

The ECCPASE bit is set by hardware when a shutdown event occurs. If Auto-restarts are not enabled, the ECCPASE bit is cleared by firmware when the cause of the shutdown clears. If Auto-restarts are enabled, the ECCPASE bit is automatically cleared when the cause of the auto-shutdown has cleared. See **Section 11.3.7.1 “Auto-shutdown and Auto-restart”** for more information.

REGISTER 11-2: PWM1CON – PWM CONFIGURATION REGISTER (ADDRESS: 16h)

R/W-0	R/W-0	R/W-0	R/W-0	R/W-0	R/W-0	R/W-0	R/W-0
PRSEN	PDC6	PDC5	PDC4	PDC3	PDC2	PDC1	PDC0
bit 7							bit 0

bit 7 **PRSEN:** PWM Restart Enable bit

1 = Upon auto-shutdown, the ECCPASE bit clears automatically once the shutdown event goes away; the PWM restarts automatically.

0 = Upon auto-shutdown, ECCPASE must be cleared in software to restart the PWM.

bit 6-0 **PDC<6:0>:** PWM Delay Count bits

Number of FOSC/4 (4*TOSC) cycles between the scheduled time when a PWM signal **should** transition active, and the **actual** time it transitions active.

Legend:

R = Readable bit	W = Writable bit	U = Unimplemented bit, read as '0'
-n = Value at POR	'1' = Bit is set	'0' = Bit is cleared x = Bit is unknown

PIC16F684

REGISTER 11-3: ECCPAS – ENHANCED CAPTURE/COMPARE/PWM AUTO-SHUTDOWN CONTROL REGISTER (ADDRESS: 17h)

R/W-0	R/W-0	R/W-0	R/W-0	R/W-0	R/W-0	R/W-0	R/W-0
ECCPASE	ECCPAS2	ECCPAS1	ECCPAS0	PSSAC1	PSSAC0	PSSBD1	PSSBD0

bit 7

bit 0

- bit 7 **ECCPASE:** ECCP Auto-shutdown Event Status bit
 1 = A shutdown event has occurred; ECCP outputs are in shutdown state
 0 = ECCP outputs are operating
- bit 6-4 **ECCPAS<2:0>:** ECCP Auto-shutdown Source Select bits
 000 = Auto-shutdown is disabled
 001 = Comparator 1 output change
 010 = Comparator 2 output change
 011 = Either Comparator 1 or 2 change
 100 = VIL on INT pin
 101 = VIL on INT pin or Comparator 1 change
 110 = VIL on INT pin or Comparator 2 change
 111 = VIL on INT pin or Comparator 1 or Comparator 2 change
- bit 3-2 **PSSACn:** Pin A and C Shutdown State Control bits
 00 = Drive Pins A and C to '0'
 01 = Drive Pins A and C to '1'
 1x = Pins A and C tri-state
- bit 1-0 **PSSBDn:** Pin B and D Shutdown State Control bits
 00 = Drive Pins B and D to '0'
 01 = Drive Pins B and D to '1'
 1x = Pins B and D tri-state

Legend:			
R = Readable bit	W = Writable bit	U = Unimplemented bit, read as '0'	
-n = Value at POR	'1' = Bit is set	'0' = Bit is cleared	x = Bit is unknown

11.3.7.1 Auto-shutdown and Auto-restart

The auto-shutdown feature can be configured to allow auto-restarts of the module following a shutdown event. This is enabled by setting the PRSEN bit of the PWM1CON register (PWM1CON<7>).

In Shutdown mode with PRSEN = 1 (Figure 11-12), the ECCPASE bit will remain set for as long as the cause of the shutdown continues. When the shutdown condition clears, the ECCPASE bit is cleared. If PRSEN = 0 (Figure 11-13), once a shutdown condition occurs, the ECCPASE bit will remain set until it is cleared by firmware. Once ECCPASE is cleared, the enhanced PWM will resume at the beginning of the next PWM period.

Note: Writing to the ECCPASE bit is disabled while a shutdown condition is active.

Independent of the PRSEN bit setting, whether the auto-shutdown source is one of the comparators or INT, the shutdown condition is a level. The ECCPASE bit cannot be cleared as long as the cause of the shutdown persists.

The Auto-shutdown mode can be forced by writing a '1' to the ECCPASE bit.

11.3.8 START-UP CONSIDERATIONS

When the ECCP module is used in the PWM mode, the application hardware must use the proper external pull-up and/or pull-down resistors on the PWM output pins. When the microcontroller is released from Reset, all of the I/O pins are in the high-impedance state. The external circuits must keep the power switch devices in the off state, until the microcontroller drives the I/O pins with the proper signal levels, or activates the PWM output(s).

The CCP1M<1:0> bits (CCP1CON<1:0>) allow the user to choose whether the PWM output signals are active-high or active-low for each pair of PWM output pins (P1A/P1C and P1B/P1D). The PWM output polarities must be selected before the PWM pins are configured as outputs. Changing the polarity configuration while the PWM pins are configured as outputs is not recommended since it may result in damage to the application circuits.

The P1A, P1B, P1C and P1D output latches may not be in the proper states when the PWM module is initialized. Enabling the PWM pins for output at the same time as the ECCP module may cause damage to the application circuit. The ECCP module must be enabled in the proper Output mode and complete a full PWM cycle before configuring the PWM pins as outputs. The completion of a full PWM cycle is indicated by the TMR2IF bit being set as the second PWM period begins.

FIGURE 11-12: PWM AUTO-SHUTDOWN (PRSEN = 1, AUTO-RESTART ENABLED)

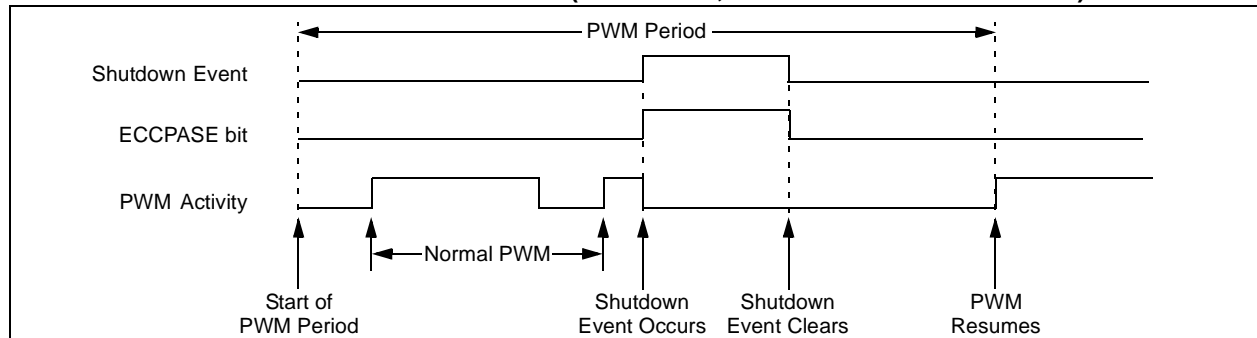
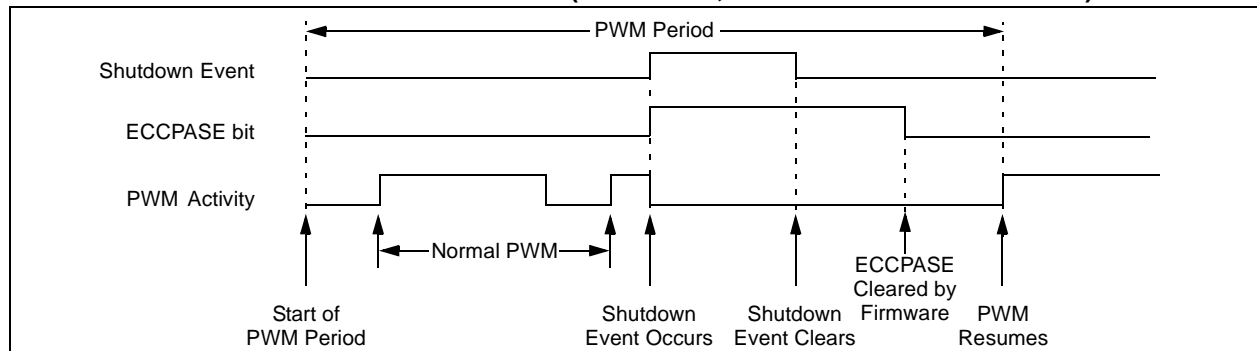

FIGURE 11-13: PWM AUTO-SHUTDOWN (PRSEN = 0, AUTO-RESTART DISABLED)



11.3.9 OPERATION IN SLEEP MODE

In Sleep mode, all clock sources are disabled. Timer2 will not increment, and the state of the module will not change. If the ECCP pin is driving a value, it will continue to drive that value. When the device wakes up, it will continue from this state.

11.3.9.1 OPERATION WITH FAIL-SAFE CLOCK MONITOR

If the Fail-Safe Clock Monitor is enabled, a clock failure will force the ECCP to be clocked from the internal oscillator clock source, which may have a different clock frequency than the primary clock.

See **Section 3.0 “Clock Sources”** for additional details.

11.3.10 EFFECTS OF A RESET

Any Reset will force all ports to Input mode and the ECCP registers to their Reset states.

This forces the Enhanced CCP module to reset to a state compatible with the standard CCP module.

11.3.11 SETUP FOR PWM OPERATION

The following steps should be taken when configuring the ECCP module for PWM operation:

1. Configure the PWM pins P1A and P1B (and P1C and P1D, if used) as inputs by setting the corresponding TRISC bits.
2. Set the PWM period by loading the PR2 register.
3. Configure the ECCP module for the desired PWM mode and configuration by loading the CCP1CON register with the appropriate values:
 - Select one of the available output configurations and direction with the P1M<1:0> bits.
 - Select the polarities of the PWM output signals with the CCP1M<3:0> bits.
4. Set the PWM duty cycle by loading the CCPR1L register and CCP1CON<5:4> bits.
5. For Half-bridge Output mode, set the dead band delay by loading PWM1CON<6:0> with the appropriate value.
6. If auto-shutdown operation is required, load the ECCPAS register:
 - Select the auto-shutdown sources using the ECCPAS<2:0> bits.
 - Select the shutdown states of the PWM output pins using PSSAC<1:0> and PSSBD<1:0> bits.
 - Set the ECCPASE bit (ECCPAS<7>).
 - Configure the comparators using the CMCON0 register (Register 8-1).
 - Configure the comparator inputs as analog inputs.
7. If auto-restart operation is required, set the PRSEN bit (PWM1CON<7>).
8. Configure and start TMR2:
 - Clear the TMR2 interrupt flag bit by clearing the TMR2IF bit (PIR1<1>).
 - Set the TMR2 prescale value by loading the T2CKPS bits (T2CON<1:0>).
 - Enable Timer2 by setting the TMR2ON bit (T2CON<2>).
9. Enable PWM outputs after a new PWM cycle has started:
 - Wait until TMR2 overflows (TMR2IF bit is set).
 - Enable the CCP1/P1A, P1B, P1C and/or P1D pin outputs by clearing the respective TRISC bits.
 - Clear the ECCPASE bit (ECCPAS<7>).

TABLE 11-5: REGISTERS ASSOCIATED WITH PWM AND TIMER2

Addr	Name	Bit 7	Bit 6	Bit 5	Bit 4	Bit 3	Bit 2	Bit 1	Bit 0	Value on POR, BOD	Value on all other Resets
0Bh/ 8Bh	INTCON	GIE	PEIE	T0IE	INTE	RAIE	TOIF	INTF	RAIF	0000 0000	0000 0000
0Ch	PIR1	EEIF	ADIF	CCP1IF	C2IF	C1IF	OSFIF	TMR2IF	TMR1IF	0000 0000	0000 0000
11h	TMR2	Timer2 Module register								0000 0000	0000 0000
12h	T2CON	—	TOUTPS3	TOUTPS2	TOUTPS1	TOUTPS0	TMR2ON	T2CKPS1	T2CKPS0	-000 0000	-000 0000
13h	CCPR1L	Capture/Compare/PWM Register1 Low Byte								xxxx xxxx	uuuu uuuu
14h	CCPR1H	Capture/Compare/PWM Register1 High Byte								xxxx xxxx	uuuu uuuu
15h	CCP1CON	P1M1	P1M0	DC1B1	DC1B0	CCP1M3	CCP1M2	CCP1M1	CCP1M0	0000 0000	0000 0000
16h	PWM1CON	PRSEN	PDC6	PDC5	PDC4	PDC3	PDC2	PDC1	PDC0	0000 0000	0000 0000
17h	ECCPAS	ECCPASE	ECCPAS2	ECCPAS1	ECCPAS0	PSSAC1	PSSAC0	PSSBD1	PSSBD0	0000 0000	0000 0000
87h	TRISC	—	—	TRISC5	TRISC4	TRISC3	TRISC2	TRISC1	TRISC0	--11 1111	--11 1111
8Ch	PIE1	EEIE	ADIE	CCP1IE	C2IE	C1IE	OSFIE	TMR2IE	TMR1IE	0000 0000	0000 0000
92h	PR2	Timer2 Module Period register								1111 1111	1111 1111

Legend: — = Unimplemented locations, read as '0', u = unchanged, x = Unknown. Shaded cells are not used by the Capture, Compare or Timer1 module.

PIC16F684

NOTES:

12.0 SPECIAL FEATURES OF THE CPU

The PIC16F684 has a host of features intended to maximize system reliability, minimize cost through elimination of external components, provide power saving features and offer code protection.

These features are:

- Reset
 - Power-on Reset (POR)
 - Power-up Timer (PWRT)
 - Oscillator Start-up Timer (OST)
 - Brown-out Detect (BOD)
- Interrupts
- Watchdog Timer (WDT)
- Oscillator selection
- Sleep
- Code protection
- ID Locations
- In-Circuit Serial Programming

The PIC16F684 has two timers that offer necessary delays on power-up. One is the Oscillator Start-up Timer (OST), intended to keep the chip in Reset until the crystal oscillator is stable. The other is the Power-up Timer (PWRT), which provides a fixed delay of 64 ms (nominal) on power-up only, designed to keep the part in Reset while the power supply stabilizes. There is also circuitry to reset the device if a brown-out occurs, which can use the Power-up Timer to provide at least a 64 ms Reset. With these three functions-on-chip, most applications need no external Reset circuitry.

The Sleep mode is designed to offer a very low -current Power-down mode. The user can wake-up from Sleep through:

- External Reset
- Watchdog Timer Wake-up
- An interrupt

Several oscillator options are also made available to allow the part to fit the application. The INTOSC option saves system cost while the LP crystal option saves power. A set of configuration bits are used to select various options (see Register 12-1).

PIC16F684

12.1 Configuration Bits

The configuration bits can be programmed (read as '0'), or left unprogrammed (read as '1') to select various device configurations as shown in Register 12-1. These bits are mapped in program memory location 2007h.

Note: Address 2007h is beyond the user program memory space. It belongs to the special configuration memory space (2000h-3FFFh), which can be accessed only during programming. See "PIC12F6XX/16F6XX Memory Programming Specification" (DS41204) for more information.

REGISTER 12-1: CONFIG – CONFIGURATION WORD (ADDRESS: 2007h)

—	—	FCMEN	IESO	BODEN1	BODEN0	CPD	CP	MCLRE	PWRTE	WDTE	FOSC2	FOSC1	FOSC0
bit 13												bit 0	

bit 13-12 **Unimplemented:** Read as '1'

bit 11 **FCMEN:** Fail-Safe Clock Monitor Enabled bit
 1 = Fail-Safe Clock Monitor is enabled
 0 = Fail-Safe Clock Monitor is disabled

bit 10 **IESO:** Internal External Switchover bit
 1 = Internal External Switchover mode is enabled
 0 = Internal External Switchover mode is disabled

bit 9-8 **BODEN<1:0>:** Brown-out Detect Selection bits⁽¹⁾
 11 = BOD enabled
 10 = BOD enabled during operation and disabled in Sleep
 01 = BOD controlled by SBODEN bit (PCON<4>)
 00 = BOD disabled

bit 7 **CPD:** Data Code Protection bit⁽²⁾
 1 = Data memory code protection is disabled
 0 = Data memory code protection is enabled

bit 6 **CP:** Code Protection bit⁽³⁾
 1 = Program memory code protection is disabled
 0 = Program memory code protection is enabled

bit 5 **MCLRE:** RA3/MCLR pin function select bit⁽⁴⁾
 1 = RA3/MCLR pin function is MCLR
 0 = RA3/MCLR pin function is digital input, MCLR internally tied to VDD

bit 4 **PWRTE:** Power-up Timer Enable bit
 1 = PWRT disabled
 0 = PWRT enabled

bit 3 **WDTE:** Watchdog Timer Enable bit
 1 = WDT enabled
 0 = WDT disabled and can be enabled by SWDTEN bit (WDTCON<0>)

bit 2-0 **FOSC<2:0>:** Oscillator Selection bits
 111 = RC oscillator: CLKOUT function on RA4/OSC2/CLKOUT pin, RC on RA5/OSC1/CLKIN
 110 = RCIO oscillator: I/O function on RA4/OSC2/CLKOUT pin, RC on RA5/OSC1/CLKIN
 101 = INTOSC oscillator: CLKOUT function on RA4/OSC2/CLKOUT pin, I/O function on RA5/OSC1/CLKIN
 100 = INTOSCIO oscillator: I/O function on RA4/OSC2/CLKOUT pin, I/O function on RA5/OSC1/CLKIN
 011 = EC: I/O function on RA4/OSC2/CLKOUT pin, CLKIN on RA5/OSC1/CLKIN
 010 = HS oscillator: High-speed crystal/resonator on RA4/OSC2/CLKOUT and RA5/OSC1/CLKIN
 001 = XT oscillator: Crystal/resonator on RA4/OSC2/CLKOUT and RA5/OSC1/CLKIN
 000 = LP oscillator: Low-power crystal on RA4/OSC2/CLKOUT and RA5/OSC1/CLKIN

- Note 1:** Enabling Brown-out Detect does not automatically enable Power-up Timer.
Note 2: The entire data EEPROM will be erased when the code protection is turned off.
Note 3: The entire program memory will be erased when the code protection is turned off.
Note 4: When MCLR is asserted in INTOSC or RC mode, the internal clock oscillator is disabled.

Legend:

R = Readable	W = Writable bit	U = Unimplemented bit, read as '0'
-n = Value at POR	'1' = Bit is set	'0' = Bit is cleared
		x = Bit is unknown

12.2 Calibration Bits

The Brown-out Detect (BOD), Power-on Reset (POR) and 8 MHz internal oscillator (HFINTOSC) are factory calibrated. These calibration values are stored in the Calibration Word register, as shown in Register 12-2 and are mapped in program memory location 2008h.

The Calibration Word register is not erased when the device is erased when using the procedure described in the “PIC12F6XX/16F6XX Memory Programming Specification” (DS41204). Therefore, it is not necessary to store and reprogram these values when the device is erased.

Note: Address 2008h is beyond the user program memory space. It belongs to the special configuration memory space (2000h-3FFFh), which can be accessed only during programming. See “PIC12F6XX/16F6XX Memory Programming Specification” (DS41204) for more information.

REGISTER 12-2: CALIB – CALIBRATION WORD (ADDRESS: 2008h)

	—	FCAL6	FCAL5	FCAL4	FCAL3	FCAL2	FCAL1	FCAL0	—	POR1	POR0	BOD2	BOD1	BOD0	
	bit 13														bit 0

- bit 13 **Unimplemented: Read as ‘0’**
- bit 12-6 **FCAL<6:0>:** Internal Oscillator Calibration bits
 - 01111111 = Maximum frequency
 - .
 - .
 - 00000001
 - 00000000 = Center frequency
 - 11111111
 - .
 - .
 - 10000000 = Minimum frequency
- bit 5 **Unimplemented: Read as ‘0’**
- bit 4-3 **POR<1:0>:** POR Calibration bits
 - 00 = Lowest POR voltage
 - 11 = Highest POR voltage
- bit 2-0 **BOD<2:0>:** BOD Calibration bits
 - 000 = Reserved
 - 001 = Lowest BOD voltage
 - 111 = Highest BOD voltage

Legend:

R = Readable	W = Writable bit	U = Unimplemented bit, read as ‘0’
-n = Value at POR	‘1’ = Bit is set	‘0’ = Bit is cleared x = Bit is unknown

PIC16F684

12.3 Reset

The PIC16F684 differentiates between various kinds of Reset:

- Power-on Reset (POR)
- WDT Reset during normal operation
- WDT Reset during Sleep
- $\overline{\text{MCLR}}$ Reset during normal operation
- $\overline{\text{MCLR}}$ Reset during Sleep
- Brown-out Detect (BOD)

Some registers are not affected in any Reset condition; their status is unknown on POR and unchanged in any other Reset. Most other registers are reset to a "Reset state" on:

- Power-on Reset
- $\overline{\text{MCLR}}$ Reset
- $\overline{\text{MCLR}}$ Reset during Sleep
- WDT Reset
- Brown-out Detect (BOD)

They are not affected by a WDT wake-up since this is viewed as the resumption of normal operation. $\overline{\text{TO}}$ and PD bits are set or cleared differently in different Reset situations, as indicated in Table 12-2. These bits are used in software to determine the nature of the Reset. See Table 12-4 for a full description of Reset states of all registers.

A simplified block diagram of the On-Chip Reset Circuit is shown in Figure 12-1.

The $\overline{\text{MCLR}}$ Reset path has a noise filter to detect and ignore small pulses. See **Section 15.0 "Electrical Specifications"** for pulse-width specifications.

FIGURE 12-1: SIMPLIFIED BLOCK DIAGRAM OF ON-CHIP RESET CIRCUIT

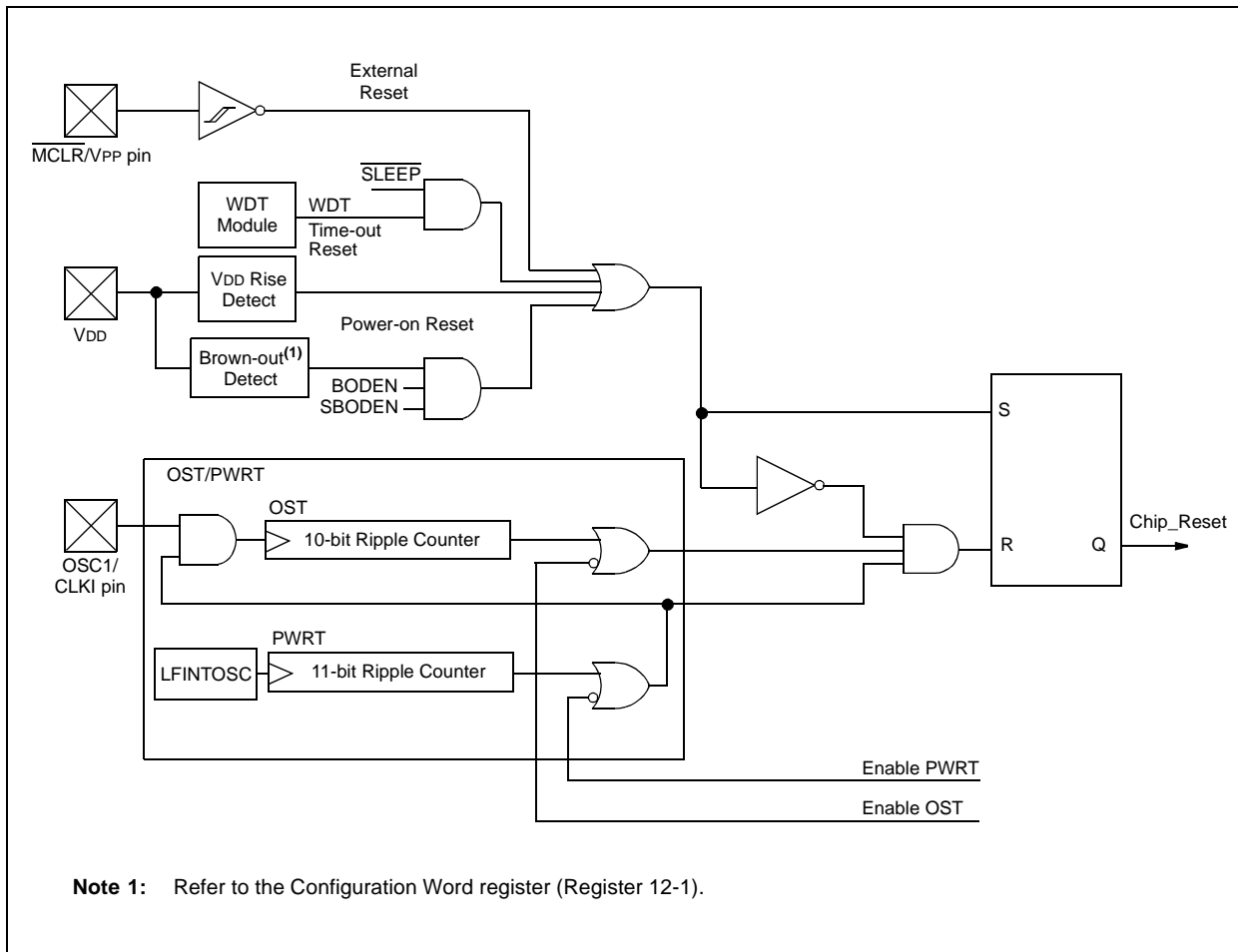

12.3.1 POWER-ON RESET

The on-chip POR circuit holds the chip in Reset until V_{DD} has reached a high enough level for proper operation. To take advantage of the POR, simply connect the $\overline{\text{MCLR}}$ pin through a resistor to V_{DD}. This will eliminate external RC components usually needed to create Power-on Reset. A maximum rise time for V_{DD} is required. See Section 15.0 “Electrical Specifications” for details. If the BOD is enabled, the maximum rise time specification does not apply. The BOD circuitry will keep the device in Reset until V_{DD} reaches V_{BOD} (see Section 12.3.5 “Brown-Out Detect (BOD)”).

Note: The POR circuit does not produce an internal Reset when V_{DD} declines. To re-enable the POR, V_{DD} must reach V_{SS} for a minimum of 100 μs .

When the device starts normal operation (exits the Reset condition), device operating parameters (i.e., voltage, frequency, temperature, etc.) must be met to ensure operation. If these conditions are not met, the device must be held in Reset until the operating conditions are met.

For additional information, refer to Application Note AN607, “Power-up Trouble Shooting” (DS00607).

12.3.2 $\overline{\text{MCLR}}$

PIC16F684 has a noise filter in the $\overline{\text{MCLR}}$ Reset path. The filter will detect and ignore small pulses.

It should be noted that a WDT Reset does not drive $\overline{\text{MCLR}}$ pin low.

The behavior of the ESD protection on the $\overline{\text{MCLR}}$ pin has been altered from early devices of this family. Voltages applied to the pin that exceed its specification can result in both $\overline{\text{MCLR}}$ Resets and excessive current beyond the device specification during the ESD event. For this reason, Microchip recommends that the $\overline{\text{MCLR}}$ pin no longer be tied directly to V_{DD}. The use of an RC network, as shown in Figure 12-2, is suggested.

An internal $\overline{\text{MCLR}}$ option is enabled by clearing the MCLRE bit in the Configuration Word register. When cleared, $\overline{\text{MCLR}}$ is internally tied to V_{DD} and an internal weak pull-up is enabled for the $\overline{\text{MCLR}}$ pin. In-Circuit Serial Programming is not affected by selecting the internal $\overline{\text{MCLR}}$ option.

FIGURE 12-2: RECOMMENDED $\overline{\text{MCLR}}$ CIRCUIT

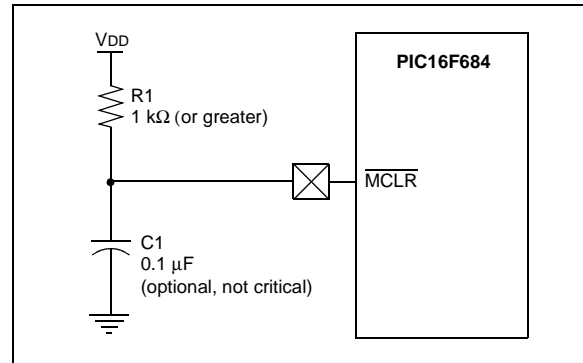

12.3.3 POWER-ON RESET (POR)

The on-chip POR circuit holds the chip in Reset until V_{DD} has reached a high enough level for proper operation. To take advantage of the POR, simply connect the $\overline{\text{MCLR}}$ pin through a resistor to V_{DD}. This will eliminate external RC components usually needed to create Power-on Reset. A maximum rise time for V_{DD} is required. See Section 15.0 “Electrical Specifications” for details. If the BOD is enabled, the maximum rise time specification does not apply. The BOD circuitry will keep the device in Reset until V_{DD} reaches V_{BOD} (see Section 12.3.5 “Brown-Out Detect (BOD)”).

Note: The POR circuit does not produce an internal Reset when V_{DD} declines. To re-enable the POR, V_{DD} must reach V_{SS} for a minimum of 100 μs .

When the device starts normal operation (exits the Reset condition), device operating parameters (i.e., voltage, frequency, temperature, etc.) must be met to ensure operation. If these conditions are not met, the device must be held in Reset until the operating conditions are met.

For additional information, refer to Application Note AN607, “Power-up Trouble Shooting” (DS00607).

PIC16F684

12.3.4 POWER-UP TIMER (PWRT)

The Power-up Timer provides a fixed 64 ms (nominal) time-out on power-up only, from POR or Brown-out Detect. The Power-up Timer operates from the 31 kHz LFINTOSC oscillator. For more information, see **Section 3.4 “Internal Clock Modes”**. The chip is kept in Reset as long as PWRT is active. The PWRT delay allows the VDD to rise to an acceptable level. A configuration bit, PWRTE, can disable (if set) or enable (if cleared or programmed) the Power-up Timer. The Power-up Timer should be enabled when Brown-out Detect is enabled, although it is not required.

The Power-up Timer delay will vary from chip-to-chip and vary due to:

- VDD variation
- Temperature variation
- Process variation

See DC parameters for details (**Section 15.0 “Electrical Specifications”**).

12.3.5 BROWN-OUT DETECT (BOD)

The BODEN0 and BODEN1 bits in the Configuration Word register select one of four BOD modes. Two modes have been added to allow software or hardware control of the BOD enable. When BODEN<1:0> = 01, the SBODEN bit (PCON<4>) enables/disables the BOD allowing it to be controlled in software. By selecting BODEN<1:0>, the BOD is automatically disabled in Sleep to conserve power and enabled on wake-up. In this mode, the SBODEN bit is disabled. See Register 12-1 for the configuration word definition.

If VDD falls below VBOD for greater than parameter (TBOD) (see **Section 15.0 “Electrical Specifications”**), the Brown-out situation will reset the device. This will occur regardless of VDD slew rate. A Reset is not insured to occur if VDD falls below VBOD for less than parameter (TBOD).

On any Reset (Power-on, Brown-out Detect, Watchdog timer, etc.), the chip will remain in Reset until VDD rises above VBOD (see Figure 12-3). The Power-up Timer will now be invoked, if enabled and will keep the chip in Reset an additional 64 ms.

Note: The Power-up Timer is enabled by the PWRTE bit in the Configuration Word register.

If VDD drops below VBOD while the Power-up Timer is running, the chip will go back into a Brown-out Detect and the Power-up Timer will be re-initialized. Once VDD rises above VBOD, the Power-up Timer will execute a 64 ms Reset.

12.3.6 BOD CALIBRATION

The PIC16F684 stores the BOD calibration values in fuses located in the Calibration Word register (2008h). The Calibration Word register is not erased when using the specified bulk erase sequence in the “PIC12F6XX/16F6XX Memory Programming Specification” (DS41204) and thus, does not require reprogramming.

Note: Address 2008h is beyond the user program memory space. It belongs to the special configuration memory space (2000h-3FFFh), which can be accessed only during programming. See “PIC12F6XX/16F6XX Memory Programming Specification” (DS41204) for more information.

FIGURE 12-3: BROWN-OUT SITUATIONS

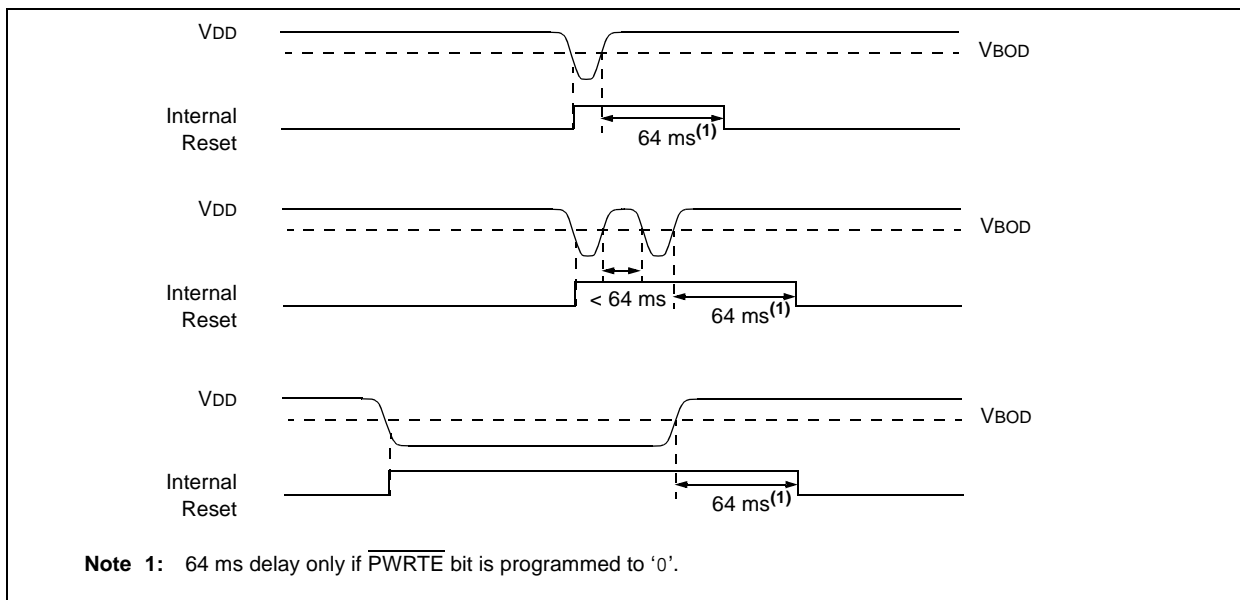

12.3.7 TIME-OUT SEQUENCE

On power-up, the time-out sequence is as follows: first, PWRT time-out is invoked after POR has expired, then OST is activated after the PWRT time-out has expired. The total time-out will vary based on oscillator configuration and $\overline{\text{PWRTE}}$ bit status. For example, in EC mode with $\overline{\text{PWRTE}}$ bit erased (PWRT disabled), there will be no time-out at all. Figure 12-4, Figure 12-5 and Figure 12-6 depict time-out sequences. The device can execute code from the INTOSC while OST is active by enabling Two-Speed Start-up or Fail-Safe Monitor (see Section 3.6.2 “Two-Speed Start-up Sequence” and Section 3.7 “Fail-Safe Clock Monitor”).

Since the time-outs occur from the POR pulse, if $\overline{\text{MCLR}}$ is kept low long enough, the time-outs will expire. Then, bringing $\overline{\text{MCLR}}$ high will begin execution immediately (see Figure 12-5). This is useful for testing purposes or to synchronize more than one PIC16F684 device operating in parallel.

Table 12-5 shows the Reset conditions for some special registers, while Table 12-4 shows the Reset conditions for all the registers.

12.3.8 POWER CONTROL (PCON) REGISTER

The Power Control register PCON (address 8Eh) has two status bits to indicate what type of Reset that last occurred.

Bit 0 is $\overline{\text{BOD}}$ (Brown-out). $\overline{\text{BOD}}$ is unknown on Power-on Reset. It must then be set by the user and checked on subsequent Resets to see if $\overline{\text{BOD}} = 0$, indicating that a Brown-out has occurred. The BOD Status bit is a “don’t care” and is not necessarily predictable if the brown-out circuit is disabled ($\text{BODEN} < 1:0 > = 00$ in the Configuration Word register).

Bit 1 is $\overline{\text{POR}}$ (Power-on Reset). It is a ‘0’ on Power-on Reset and unaffected otherwise. The user must write a ‘1’ to this bit following a Power-on Reset. On a subsequent Reset, if $\overline{\text{POR}}$ is ‘0’, it will indicate that a Power-on Reset has occurred (i.e., VDD may have gone too low).

For more information, see Section 4.2.3 “Ultra Low-Power Wake-up” and Section 12.3.5 “Brown-Out Detect (BOD)”.

TABLE 12-1: TIME-OUT IN VARIOUS SITUATIONS

Oscillator Configuration	Power-up		Brown-out Detect		Wake-up from Sleep
	$\overline{\text{PWRTE}} = 0$	$\overline{\text{PWRTE}} = 1$	$\overline{\text{PWRTE}} = 0$	$\overline{\text{PWRTE}} = 1$	
XT, HS, LP	$\text{TPWRT} + 1024 \cdot \text{TOSC}$	$1024 \cdot \text{TOSC}$	$\text{TPWRT} + 1024 \cdot \text{TOSC}$	$1024 \cdot \text{TOSC}$	$1024 \cdot \text{TOSC}$
RC, EC, INTOSC	TPWRT	—	TPWRT	—	—

TABLE 12-2: STATUS/PCON BITS AND THEIR SIGNIFICANCE

$\overline{\text{POR}}$	$\overline{\text{BOD}}$	$\overline{\text{TO}}$	PD	Condition
0	u	1	1	Power-on Reset
1	0	1	1	Brown-out Detect
u	u	0	u	WDT Reset
u	u	0	0	WDT Wake-up
u	u	u	u	$\overline{\text{MCLR}}$ Reset during normal operation
u	u	1	0	$\overline{\text{MCLR}}$ Reset during Sleep

Legend: u = unchanged, x = unknown

TABLE 12-3: SUMMARY OF REGISTERS ASSOCIATED WITH BROWN-OUT

Address	Name	Bit 7	Bit 6	Bit 5	Bit 4	Bit 3	Bit 2	Bit 1	Bit 0	Value on POR, BOD	Value on all other Resets ⁽¹⁾
03h	STATUS	IRP	RP1	RPO	$\overline{\text{TO}}$	PD	Z	DC	C	0001 1xxx	000q quuu
8Eh	PCON	—	—	ULPWUE	SBODEN	—	—	$\overline{\text{POR}}$	$\overline{\text{BOD}}$	--01 --qg	--0u --uu

Legend: u = unchanged, x = unknown, — = unimplemented bit, reads as ‘0’, q = value depends on condition. Shaded cells are not used by BOD.

Note 1: Other (non Power-up) Resets include $\overline{\text{MCLR}}$ Reset and Watchdog Timer Reset during normal operation.

PIC16F684

FIGURE 12-4: TIME-OUT SEQUENCE ON POWER-UP (DELAYED $\overline{\text{MCLR}}$): CASE 1

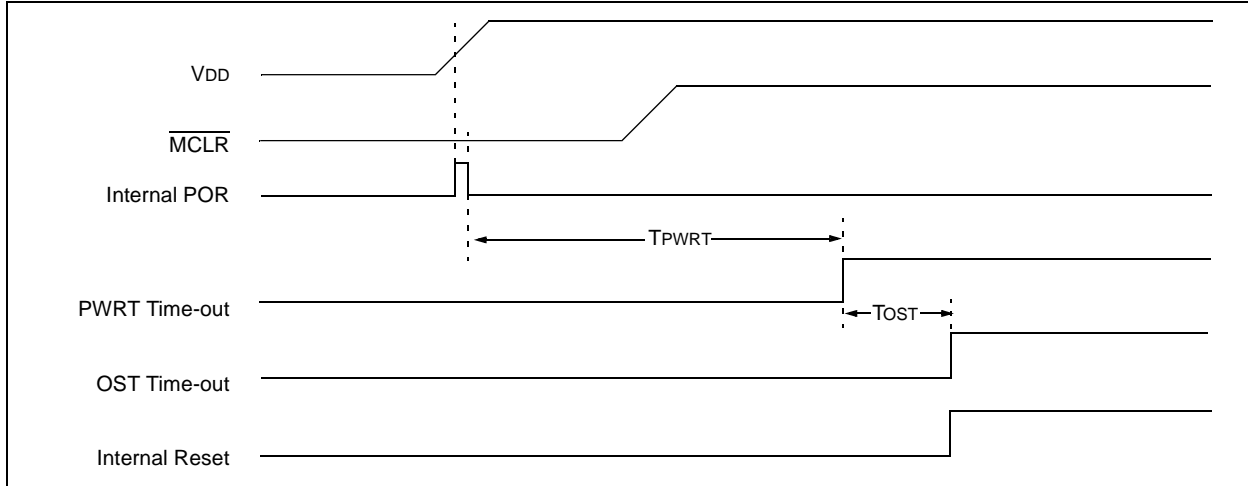

FIGURE 12-5: TIME-OUT SEQUENCE ON POWER-UP (DELAYED $\overline{\text{MCLR}}$): CASE 2

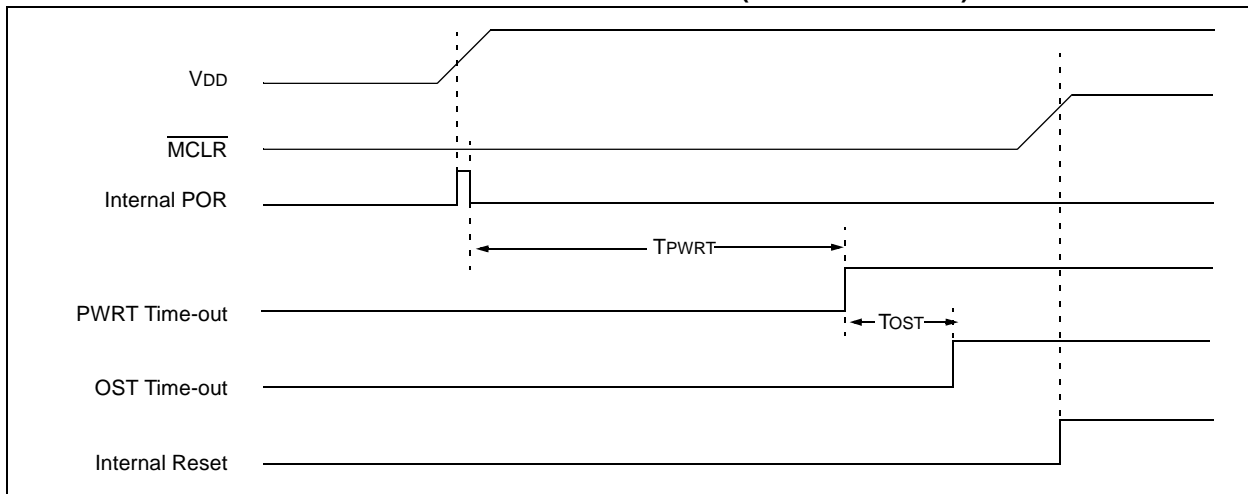

FIGURE 12-6: TIME-OUT SEQUENCE ON POWER-UP ($\overline{\text{MCLR}}$ WITH VDD)

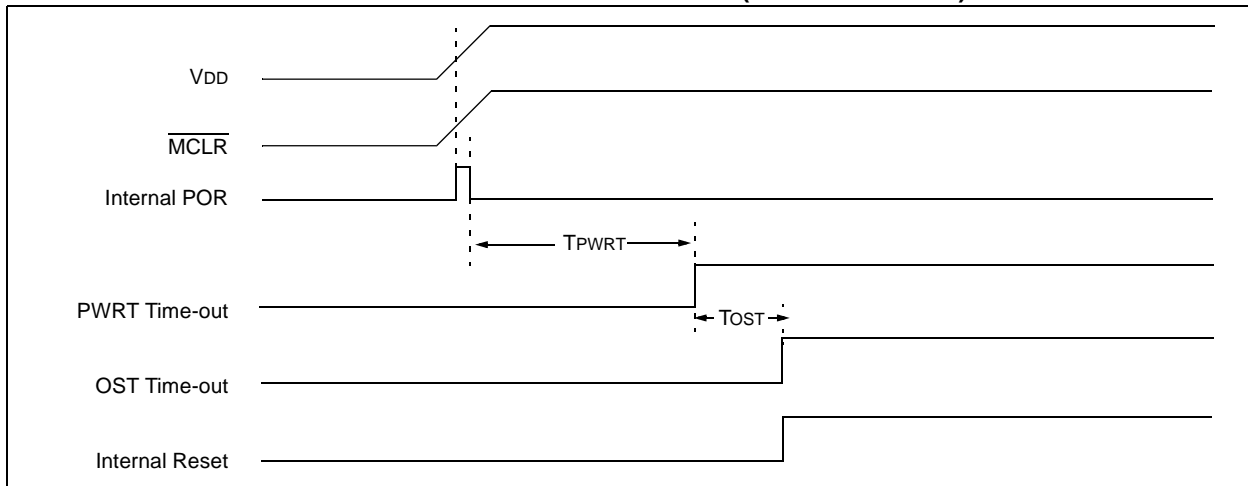

TABLE 12-4: INITIALIZATION CONDITION FOR REGISTER

Register	Address	Power-on Reset	MCLR Reset WDT Reset Brown-out Detect ⁽¹⁾	Wake-up from Sleep through Interrupt Wake-up from Sleep through WDT Time-out
W	—	xxxx xxxx	uuuu uuuu	uuuu uuuu
INDF	00h/80h	xxxx xxxx	xxxx xxxx	uuuu uuuu
TMR0	01h	xxxx xxxx	uuuu uuuu	uuuu uuuu
PCL	02h/82h	0000 0000	0000 0000	PC + 1 ⁽³⁾
STATUS	03h/83h	0001 1xxx	000q quuu ⁽⁴⁾	uuuq quuu ⁽⁴⁾
FSR	04h/84h	xxxx xxxx	uuuu uuuu	uuuu uuuu
PORTA	05h	--xx xx00	--00 0000	--uu uuuu
PORTC	07h	--xx xx00	--00 0000	--uu uuuu
PCLATH	0Ah/8Ah	---0 0000	---0 0000	---u uuuu
INTCON	0Bh/8Bh	0000 0000	0000 0000	uuuu uuuu ⁽²⁾
PIR1	0Ch	0000 0000	0000 0000	uuuu uuuu ⁽²⁾
TMR1L	0Eh	xxxx xxxx	uuuu uuuu	uuuu uuuu
TMR1H	0Fh	xxxx xxxx	uuuu uuuu	uuuu uuuu
T1CON	10h	0000 0000	uuuu uuuu	-uuu uuuu
TMR2	11h	0000 0000	0000 0000	uuuu uuuu
T2CON	12h	-000 0000	-000 0000	-uuu uuuu
CCPR1L	13h	xxxx xxxx	uuuu uuuu	uuuu uuuu
CCPR1H	14h	xxxx xxxx	uuuu uuuu	uuuu uuuu
CCP1CON	15h	0000 0000	0000 0000	uuuu uuuu
PWM1CON	16h	0000 0000	0000 0000	uuuu uuuu
ECCPAS	17h	0000 0000	0000 0000	uuuu uuuu
WDTCON	18h	---0 1000	---0 1000	---u uuuu
CMCON0	19h	0000 0000	0000 0000	uuuu uuuu
CMCON1	1Ah	---- --10	---- --10	---- --uu
ADRESH	1Eh	xxxx xxxx	uuuu uuuu	uuuu uuuu
ADCON0	1Fh	00-0 0000	00-0 0000	uu-u uuuu
OPTION_REG	81h	1111 1111	1111 1111	uuuu uuuu
TRISA	85h	--11 1111	--11 1111	--uu uuuu
TRISC	87h	--11 1111	--11 1111	--uu uuuu
PIE1	8Ch	0000 0000	0000 0000	uuuu uuuu
PCON	8Eh	--01 --0x	--0u --uu ^(1, 5)	--uu --uu
OSCCON	8Fh	-110 x000	-110 x000	-uuu uuuu
OSCTUNE	90h	---0 0000	---u uuuu	---u uuuu
ANSEL	91h	1111 1111	1111 1111	uuuu uuuu
PR2	92h	1111 1111	1111 1111	1111 1111

Legend: u = unchanged, x = unknown, — = unimplemented bit, reads as '0', q = value depends on condition.

- Note 1:** If VDD goes too low, Power-on Reset will be activated and registers will be affected differently.
- 2:** One or more bits in INTCON and/or PIR1 will be affected (to cause wake-up).
- 3:** When the wake-up is due to an interrupt and the GIE bit is set, the PC is loaded with the interrupt vector (0004h).
- 4:** See Table 12-5 for Reset value for specific condition.
- 5:** If Reset was due to brown-out, then bit 0 = 0. All other Resets will cause bit 0 = u.

PIC16F684

TABLE 12-4: INITIALIZATION CONDITION FOR REGISTER (CONTINUED)

Register	Address	Power-on Reset	MCLR Reset WDT Reset (Continued) Brown-out Detect ⁽¹⁾	Wake-up from Sleep through Interrupt Wake-up from Sleep through WDT Time-out (Continued)
WPUA	95h	--11 -111	--11 -111	uuuu uuuu
IOCA	96h	--00 0000	--00 0000	--uu uuuu
VRCON	99h	0-0- 0000	0-0- 0000	u-u- uuuu
EEDAT	9Ah	0000 0000	0000 0000	uuuu uuuu
EEADR	9Bh	0000 0000	0000 0000	uuuu uuuu
EECON1	9Ch	---- x000	---- q000	---- uuuu
EECON2	9Dh	---- ----	---- ----	---- ----
ADRESL	9Eh	xxxx xxxx	uuuu uuuu	uuuu uuuu
ADCON1	9Fh	-000 ----	-000 ----	-uuu ----

Legend: u = unchanged, x = unknown, — = unimplemented bit, reads as '0', q = value depends on condition.

- Note 1:** If VDD goes too low, Power-on Reset will be activated and registers will be affected differently.
- 2:** One or more bits in INTCON and/or PIR1 will be affected (to cause wake-up).
- 3:** When the wake-up is due to an interrupt and the GIE bit is set, the PC is loaded with the interrupt vector (0004h).
- 4:** See Table 12-5 for Reset value for specific condition.
- 5:** If Reset was due to brown-out, then bit 0 = 0. All other Resets will cause bit 0 = u.

TABLE 12-5: INITIALIZATION CONDITION FOR SPECIAL REGISTERS

Condition	Program Counter	Status Register	PCON Register
Power-on Reset	000h	0001 1xxx	--01 --0x
MCLR Reset during normal operation	000h	000u uuuu	--0u --uu
MCLR Reset during Sleep	000h	0001 0uuu	--0u --uu
WDT Reset	000h	0000 uuuu	--0u --uu
WDT Wake-up	PC + 1	uuu0 0uuu	--uu --uu
Brown-out Detect	000h	0001 1uuu	--01 --10
Interrupt Wake-up from Sleep	PC + 1 ⁽¹⁾	uuu1 0uuu	--uu --uu

Legend: u = unchanged, x = unknown, — = unimplemented bit, reads as '0'.

- Note 1:** When the wake-up is due to an interrupt and Global Interrupt Enable bit, GIE, is set, the PC is loaded with the interrupt vector (0004h) after execution of PC + 1.

12.4 Interrupts

The PIC16F684 has 11 sources of interrupt:

- External Interrupt RA2/INT
- TMR0 Overflow Interrupt
- PORTA Change Interrupts
- 2 Comparator Interrupts
- A/D Interrupt
- Timer1 Overflow Interrupt
- Timer2 Match Interrupt
- EEPROM Data Write Interrupt
- Fail-Safe Clock Monitor Interrupt
- Enhanced CCP Interrupt

The Interrupt Control register (INTCON) and Peripheral Interrupt Request Register 1 (PIR1) record individual interrupt requests in flag bits. The INTCON register also has individual and global interrupt enable bits.

A Global Interrupt Enable bit, GIE (INTCON<7>), enables (if set) all unmasked interrupts, or disables (if cleared) all interrupts. Individual interrupts can be disabled through their corresponding enable bits in the INTCON register and PIE1 register. GIE is cleared on Reset.

The Return from Interrupt instruction, `RETFIE`, exits the interrupt routine, as well as sets the GIE bit, which re-enables unmasked interrupts.

The following interrupt flags are contained in the INTCON register:

- INT Pin Interrupt
- PORTA Change Interrupt
- TMR0 Overflow Interrupt

The peripheral interrupt flags are contained in the special register, PIR1. The corresponding interrupt enable bit is contained in special register, PIE1.

The following interrupt flags are contained in the PIR1 register:

- EEPROM Data Write Interrupt
- A/D Interrupt
- 2 Comparator Interrupts
- Timer1 Overflow Interrupt
- Timer2 Match Interrupt
- Fail-Safe Clock Monitor Interrupt
- Enhanced CCP Interrupt

When an interrupt is serviced:

- The GIE is cleared to disable any further interrupt.
- The return address is pushed onto the stack.
- The PC is loaded with 0004h.

For external interrupt events, such as the INT pin or PORTA change interrupt, the interrupt latency will be three or four instruction cycles. The exact latency depends upon when the interrupt event occurs (see Figure 12-8). The latency is the same for one or two-cycle instructions. Once in the Interrupt Service Routine, the source(s) of the interrupt can be determined by polling the interrupt flag bits. The interrupt flag bit(s) must be cleared in software before re-enabling interrupts to avoid multiple interrupt requests.

Note 1: Individual interrupt flag bits are set, regardless of the status of their corresponding mask bit or the GIE bit.

2: When an instruction that clears the GIE bit is executed, any interrupts that were pending for execution in the next cycle are ignored. The interrupts, which were ignored, are still pending to be serviced when the GIE bit is set again.

For additional information on Timer1, Timer2, comparators, A/D, data EEPROM or Enhanced CCP modules, refer to the respective peripheral section.

12.4.1 RA2/INT INTERRUPT

External interrupt on RA2/INT pin is edge-triggered; either rising if the INTEDG bit (Option<6>) is set, or falling, if the INTEDG bit is clear. When a valid edge appears on the RA2/INT pin, the INTF bit (INTCON<1>) is set. This interrupt can be disabled by clearing the INTE control bit (INTCON<4>). The INTF bit must be cleared in software in the Interrupt Service Routine before re-enabling this interrupt. The RA2/INT interrupt can wake-up the processor from Sleep, if the INTE bit was set prior to going into Sleep. The status of the GIE bit decides whether or not the processor branches to the interrupt vector following wake-up (0004h). See **Section 12.7 “Power-Down Mode (Sleep)”** for details on Sleep and Figure 12-10 for timing of wake-up from Sleep through RA2/INT interrupt.

Note: The ANSEL (91h) and CMCON0 (19h) registers must be initialized to configure an analog channel as a digital input. Pins configured as analog inputs will read '0'.

PIC16F684

12.4.2 TMR0 INTERRUPT

An overflow (FFh → 00h) in the TMR0 register will set the T0IF (INTCON<2>) bit. The interrupt can be enabled/disabled by setting/clearing T0IE (INTCON<5>) bit. See **Section 5.0 “Timer0 Module”** for operation of the Timer0 module.

12.4.3 PORTA INTERRUPT

An input change on PORTA change sets the RAIF (INTCON<0>) bit. The interrupt can be enabled/disabled by setting/clearing the RAIE (INTCON<3>) bit. Plus, individual pins can be configured through the IOCA register.

Note: If a change on the I/O pin should occur when the read operation is being executed (start of the Q2 cycle), then the RAIF interrupt flag may not get set.

FIGURE 12-7: INTERRUPT LOGIC

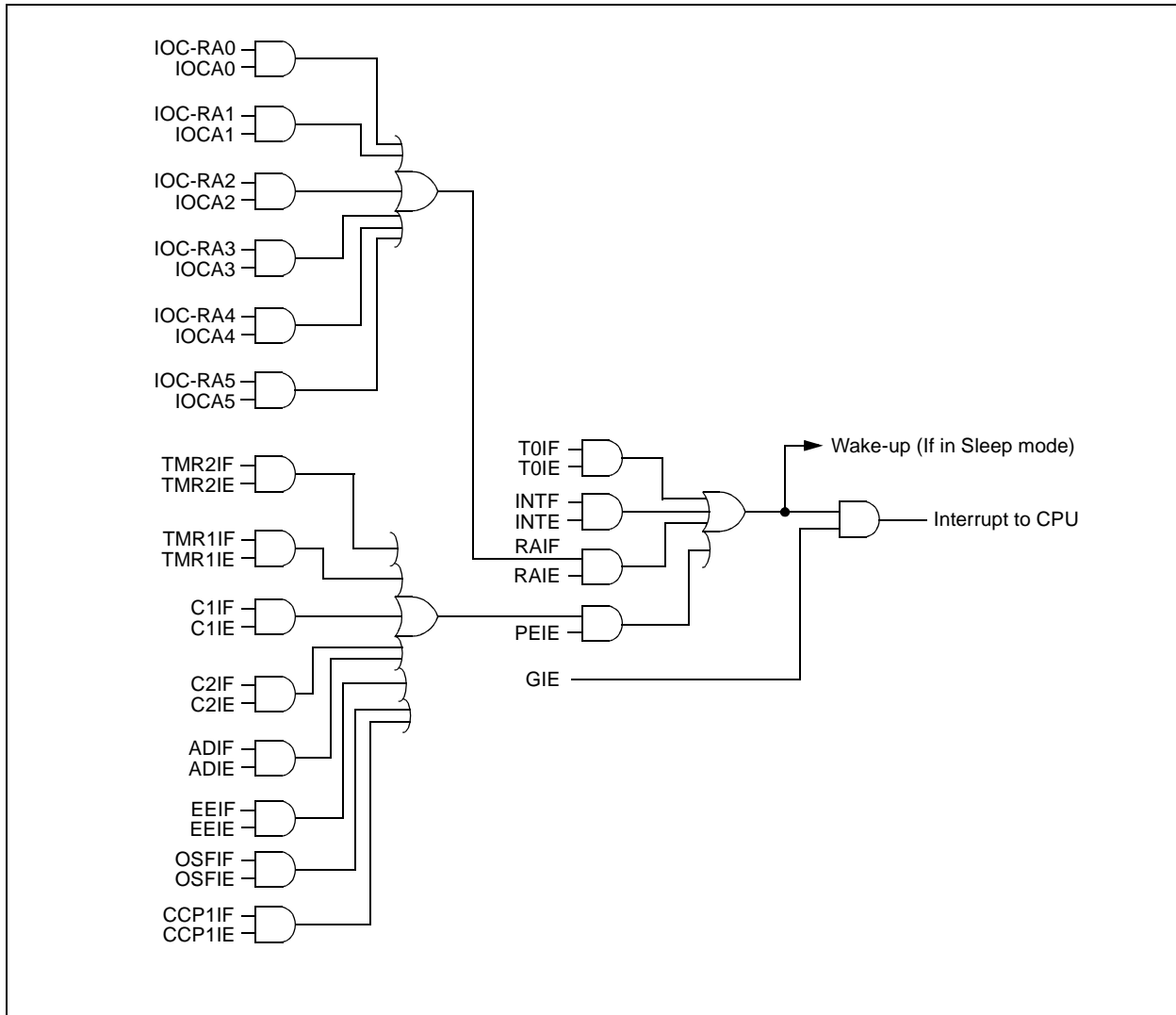

FIGURE 12-8: INT PIN INTERRUPT TIMING

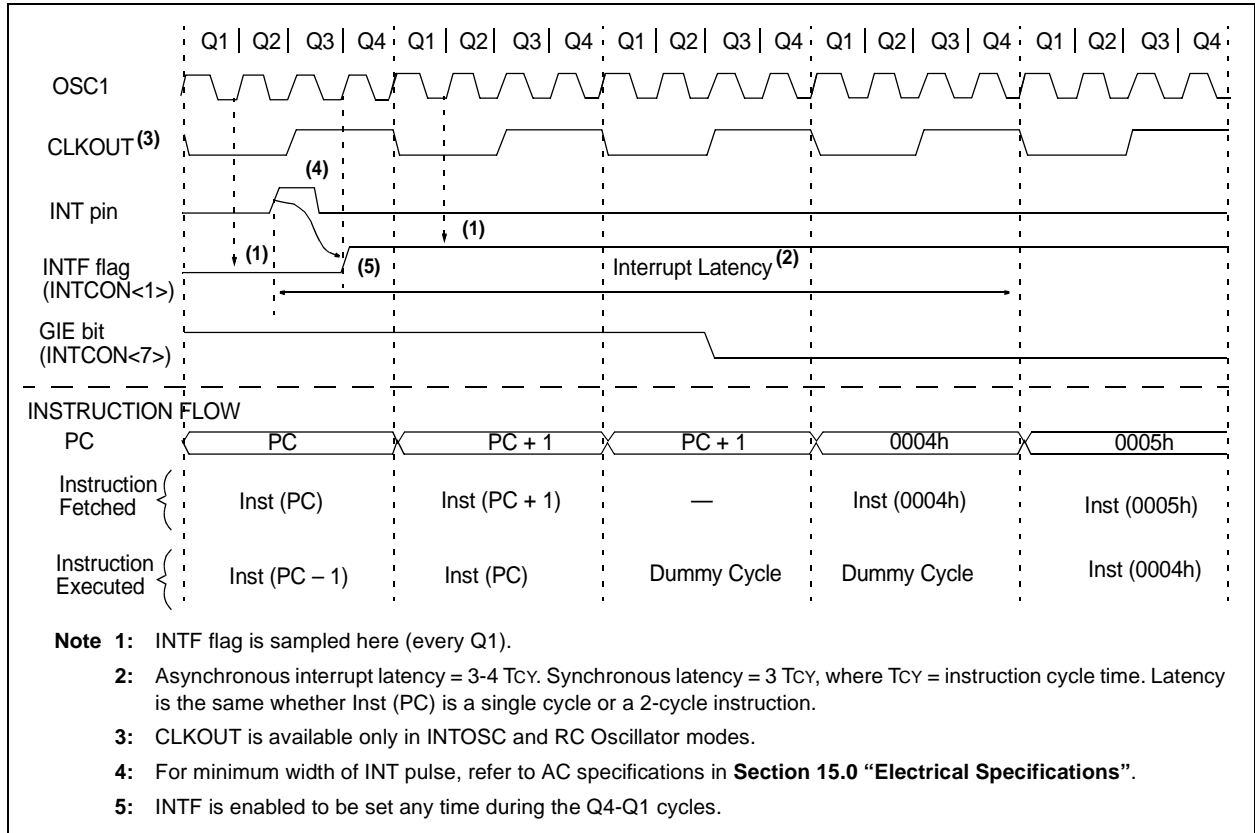

TABLE 12-6: SUMMARY OF INTERRUPT REGISTERS

Address	Name	Bit 7	Bit 6	Bit 5	Bit 4	Bit 3	Bit 2	Bit 1	Bit 0	Value on POR, BOD	Value on all other Resets
0Bh, 8Bh	INTCON	GIE	PEIE	T0IE	INTE	RAIE	T0IF	INTF	RAIF	0000 0000	0000 0000
0Ch	PIR1	EEIF	ADIF	CCP1IF	C2IF	C1IF	OSFIF	TMR2IF	TMR1IF	0000 0000	0000 0000
8Ch	PIE1	EEIE	ADIE	CCP1IE	C2IE	C1IE	OSFIE	TMR2IE	TMR1IE	0000 0000	0000 0000

Legend: x = unknown, u = unchanged, — = unimplemented read as '0', α = value depends upon condition.
 Shaded cells are not used by the interrupt module.

PIC16F684

12.5 Context Saving During Interrupts

During an interrupt, only the return PC value is saved on the stack. Typically, users may wish to save key registers during an interrupt (e.g., W and Status registers). This must be implemented in software.

Since the lower 16 bytes of all banks are common in the PIC16F684 (see Figure 2-2), temporary holding registers, W_TEMP and STATUS_TEMP, should be placed in here. These 16 locations do not require banking and therefore, make it easier to context save and restore. The same code shown in Example 12-1 can be used to:

- Store the W register
- Store the Status register
- Execute the ISR code
- Restore the Status (and Bank Select Bit register)
- Restore the W register

Note: The PIC16F684 normally does not require saving the PCLATH. However, if computed GOTOS are used in the ISR and the main code, the PCLATH must be saved and restored in the ISR.

EXAMPLE 12-1: SAVING STATUS AND W REGISTERS IN RAM

```
MOVWF  W_TEMP           ;Copy W to TEMP register
SWAPF  STATUS,W         ;Swap status to be saved into W
CLRF   STATUS           ;bank 0, regardless of current bank, Clears IRP,RP1,RP0
MOVWF  STATUS_TEMP     ;Save status to bank zero STATUS_TEMP register
:
:(ISR)                  ;Insert user code here
:
SWAPF  STATUS_TEMP,W   ;Swap STATUS_TEMP register into W
                        ;(sets bank to original state)
MOVWF  STATUS          ;Move W into Status register
SWAPF  W_TEMP,F        ;Swap W_TEMP
SWAPF  W_TEMP,W        ;Swap W_TEMP into W
```

12.6 Watchdog Timer (WDT)

For PIC16F684, the WDT has been modified from previous PIC16 devices. The new WDT is code and functionally compatible with previous PIC16 WDT modules and adds a 16-bit prescaler to the WDT. This allows the user to have a scaler value for the WDT and TMR0 at the same time. In addition, the WDT time-out value can be extended to 268 seconds. WDT is cleared under certain conditions described in Table 12-7.

12.6.1 WDT OSCILLATOR

The WDT derives its time base from the 31 kHz LFINTOSC. The LTS bit does not reflect that the LFINTOSC is enabled.

The value of WDTCON is '---0 1000' on all Resets. This gives a nominal time base of 16 ms, which is compatible with the time base generated with previous PIC16 microcontroller versions.

Note: When the Oscillator Start-up Timer (OST) is invoked, the WDT is held in Reset, because the WDT Ripple Counter is used by the OST to perform the oscillator delay count. When the OST count has expired, the WDT will begin counting (if enabled).

A new prescaler has been added to the path between the INTRC and the multiplexers used to select the path for the WDT. This prescaler is 16 bits and can be programmed to divide the INTRC by 32 to 65536, giving the WDT a nominal range of 1 ms to 268s.

12.6.2 WDT CONTROL

The WDTE bit is located in the Configuration Word register. When set, the WDT runs continuously.

When the WDTE bit in the Configuration Word register is set, the SWDTEN bit (WDTCON<0>) has no effect. If WDTE is clear, then the SWDTEN bit can be used to enable and disable the WDT. Setting the bit will enable it and clearing the bit will disable it.

The PSA and PS<2:0> bits (OPTION_REG) have the same function as in previous versions of the PIC16 Family of microcontrollers. See **Section 5.0 "Timer0 Module"** for more information.

FIGURE 12-9: WATCHDOG TIMER BLOCK DIAGRAM

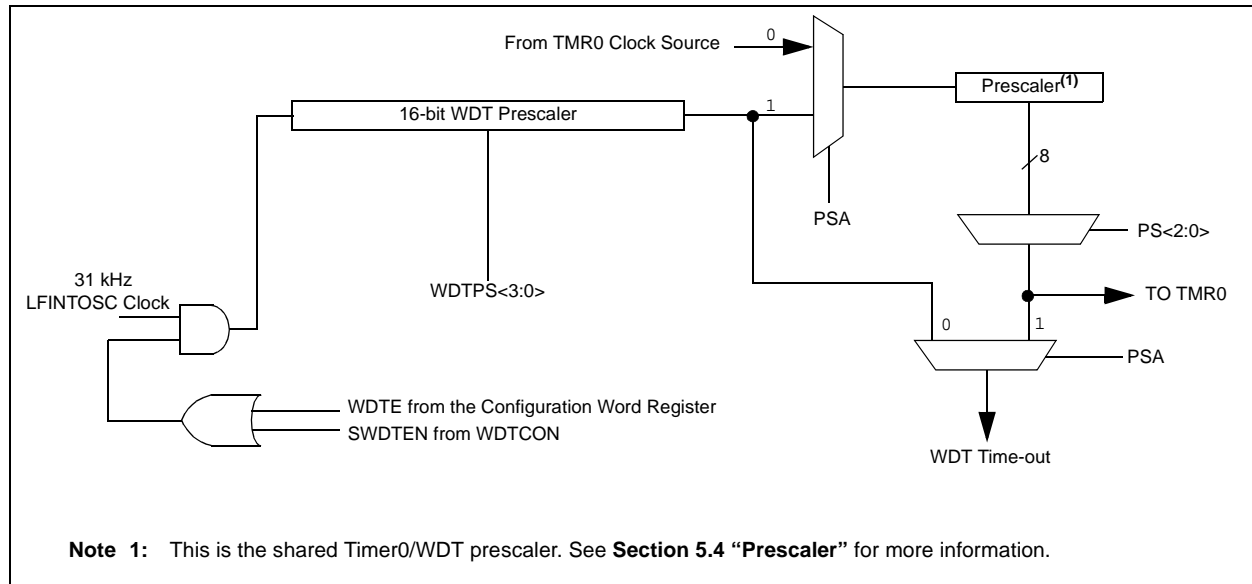

TABLE 12-7: WDT STATUS

Conditions	WDT
WDTE = 0	Cleared
CLRWDT Command	
Oscillator Fail Detected	
Exit Sleep + System Clock = T1OSC, EXTRC, INTRC, EXTCLK	
Exit Sleep + System Clock = XT, HS, LP	Cleared until the end of OST

PIC16F684

REGISTER 12-3: WDTCON – WATCHDOG TIMER CONTROL REGISTER (ADDRESS: 18h)

U-0	U-0	U-0	R/W-0	R/W-1	R/W-0	R/W-0	R/W-0	
—	—	—	WDTPS3	WDTPS2	WDTPS1	WDTPS0	SWDTEN	
bit 7								bit 0

bit 7-5 **Unimplemented:** Read as '0'

bit 4-1 **WDTPS<3:0>:** Watchdog Timer Period Select bits

Bit Value = Prescale Rate

0000	= 1:32
0001	= 1:64
0010	= 1:128
0011	= 1:256
0100	= 1:512 (Reset value)
0101	= 1:1024
0110	= 1:2048
0111	= 1:4096
1000	= 1:8192
1001	= 1:16384
1010	= 1:32768
1011	= 1:65536
1100	= reserved
1101	= reserved
1110	= reserved
1111	= reserved

bit 0 **SWDTEN:** Software Enable or Disable the Watchdog Timer⁽¹⁾

1 = WDT is turned on
0 = WDT is turned off (Reset value)

Note 1: If WDTE configuration bit = 1, then WDT is always enabled, irrespective of this control bit. If WDTE configuration bit = 0, then it is possible to turn WDT on/off with this control bit.

Legend:			
R = Readable bit	W = Writable bit	U = Unimplemented bit, read as '0'	
-n = Value at POR	'1' = Bit is set	'0' = Bit is cleared	x = Bit is unknown

TABLE 12-8: SUMMARY OF WATCHDOG TIMER REGISTERS

Address	Name	Bit 7	Bit 6	Bit 5	Bit 4	Bit 3	Bit 2	Bit 1	Bit 0
18h	WDTCON	—	—	—	WDTPS3	WDTPS2	WSTPS1	WDTPS0	SWDTEN
81h	OPTION_REG	RAPU	INTEDG	T0CS	T0SE	PSA	PS2	PS1	PS0
2007h ⁽¹⁾	CONFIG	CPD	CP	MCLRE	PWRTE	WDTE	FOSC2	FOSC1	FOSC0

Legend: Shaded cells are not used by the Watchdog Timer.

Note 1: See Register 12-1 for operation of all Configuration Word register bits.

12.7 Power-Down Mode (Sleep)

The Power-down mode is entered by executing a `SLEEP` instruction.

If the Watchdog Timer is enabled:

- WDT will be cleared but keeps running.
- PD bit in the Status register is cleared.
- \overline{TO} bit is set.
- Oscillator driver is turned off.
- I/O ports maintain the status they had before `SLEEP` was executed (driving high, low or high-impedance).

For lowest current consumption in this mode, all I/O pins should be either at V_{DD} or V_{SS} , with no external circuitry drawing current from the I/O pin and the comparators and CV_{REF} should be disabled. I/O pins that are high-impedance inputs should be pulled high or low externally to avoid switching currents caused by floating inputs. The T_{OCLK} input should also be at V_{DD} or V_{SS} for lowest current consumption. The contribution from on-chip pull-ups on $PORTA$ should be considered.

The \overline{MCLR} pin must be at a logic high level.

Note: It should be noted that a Reset generated by a WDT time-out does not drive \overline{MCLR} pin low.

12.7.1 WAKE-UP FROM SLEEP

The device can wake-up from Sleep through one of the following events:

1. External Reset input on \overline{MCLR} pin.
2. Watchdog Timer wake-up (if WDT was enabled).
3. Interrupt from $RA2/INT$ pin, $PORTA$ change or a peripheral interrupt.

The first event will cause a device Reset. The two latter events are considered a continuation of program execution. The \overline{TO} and PD bits in the Status register can be used to determine the cause of device Reset. The PD bit, which is set on power-up, is cleared when Sleep is invoked. \overline{TO} bit is cleared if WDT wake-up occurred.

The following peripheral interrupts can wake the device from Sleep:

1. TMR1 interrupt. Timer1 must be operating as an asynchronous counter.
2. ECCP Capture mode interrupt.
3. Special event trigger (Timer1 in Asynchronous mode using an external clock).
4. A/D conversion (when A/D clock source is RC).
5. EEPROM write operation completion.
6. Comparator output changes state.
7. Interrupt-on-change.
8. External Interrupt from INT pin.

Other peripherals cannot generate interrupts since during Sleep, no on-chip clocks are present.

When the `SLEEP` instruction is being executed, the next instruction ($PC + 1$) is prefetched. For the device to wake-up through an interrupt event, the corresponding interrupt enable bit must be set (enabled). Wake-up is regardless of the state of the GIE bit. If the GIE bit is clear (disabled), the device continues execution at the instruction after the `SLEEP` instruction. If the GIE bit is set (enabled), the device executes the instruction after the `SLEEP` instruction, then branches to the interrupt address (0004h). In cases where the execution of the instruction following `SLEEP` is not desirable, the user should have a `NOP` after the `SLEEP` instruction.

Note: If the global interrupts are disabled (GIE is cleared), but any interrupt source has both its interrupt enable bit and the corresponding interrupt flag bits set, the device will immediately wake-up from Sleep. The `SLEEP` instruction is completely executed.

The WDT is cleared when the device wakes up from Sleep, regardless of the source of wake-up.

12.7.2 WAKE-UP USING INTERRUPTS

When global interrupts are disabled (GIE cleared) and any interrupt source has both its interrupt enable bit and interrupt flag bit set, one of the following will occur:

- If the interrupt occurs **before** the execution of a `SLEEP` instruction, the `SLEEP` instruction will complete as a `NOP`. Therefore, the WDT and WDT prescaler and postscaler (if enabled) will not be cleared, the \overline{TO} bit will not be set and the PD bit will not be cleared.
- If the interrupt occurs **during or after** the execution of a `SLEEP` instruction, the device will immediately wake-up from Sleep. The `SLEEP` instruction will be completely executed before the wake-up. Therefore, the WDT and WDT prescaler and postscaler (if enabled) will be cleared, the \overline{TO} bit will be set and the PD bit will be cleared.

Even if the flag bits were checked before executing a `SLEEP` instruction, it may be possible for flag bits to become set before the `SLEEP` instruction completes. To determine whether a `SLEEP` instruction executed, test the PD bit. If the PD bit is set, the `SLEEP` instruction was executed as a `NOP`.

To ensure that the WDT is cleared, a `CLRWDT` instruction should be executed before a `SLEEP` instruction.

PIC16F684

FIGURE 12-10: WAKE-UP FROM SLEEP THROUGH INTERRUPT

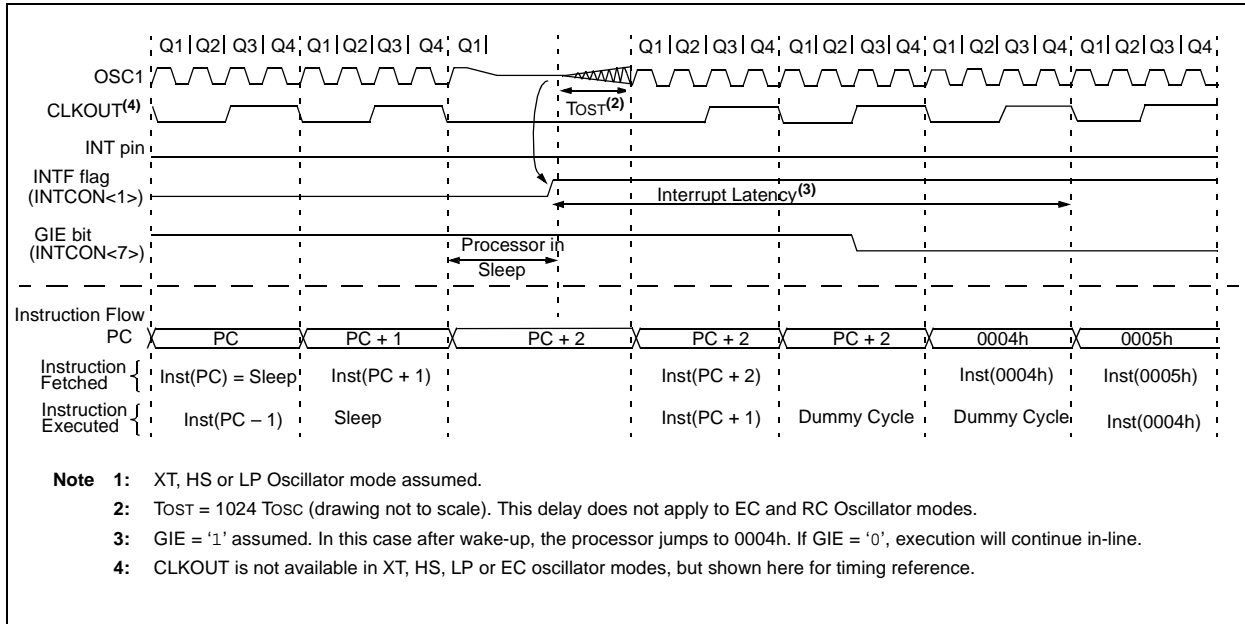

12.8 Code Protection

If the code protection bit(s) have not been programmed, the on-chip program memory can be read out using ICSP™ for verification purposes.

Note: The entire data EEPROM and Flash program memory will be erased when the code protection is turned off. See the “PIC12F6XX/16F6XX Memory Programming Specification” (DS41204) for more information.

12.9 ID Locations

Four memory locations (2000h-2003h) are designated as ID locations where the user can store checksum or other code identification numbers. These locations are not accessible during normal execution but are readable and writable during Program/Verify mode. Only the Least Significant 7 bits of the ID locations are used.

12.10 In-Circuit Serial Programming

The PIC16F684 microcontrollers can be serially programmed while in the end application circuit. This is simply done with two lines for clock and data and three other lines for:

- power
- ground
- programming voltage

This allows customers to manufacture boards with unprogrammed devices and then program the microcontroller just before shipping the product. This also allows the most recent firmware or a custom firmware to be programmed.

The device is placed into a Program/Verify mode by holding the RA0 and RA1 pins low, while raising the MCLR (VPP) pin from V_{IL} to V_{IH} . See the “PIC12F6XX/16F6XX Memory Programming Specification” (DS41204) for more information. RA0 becomes the programming data and RA1 becomes the programming clock. Both RA0 and RA1 are Schmitt Trigger inputs in this mode.

After Reset, to place the device into Program/Verify mode, the Program Counter (PC) is at location 00h. A 6-bit command is then supplied to the device. Depending on the command, 14 bits of program data are then supplied to or from the device, depending on whether the command was a load or a read. For complete details of serial programming, please refer to the “PIC12F6XX/16F6XX Memory Programming Specification” (DS41204).

A typical In-Circuit Serial Programming connection is shown in Figure 12-11.

FIGURE 12-11: TYPICAL IN-CIRCUIT SERIAL PROGRAMMING CONNECTION

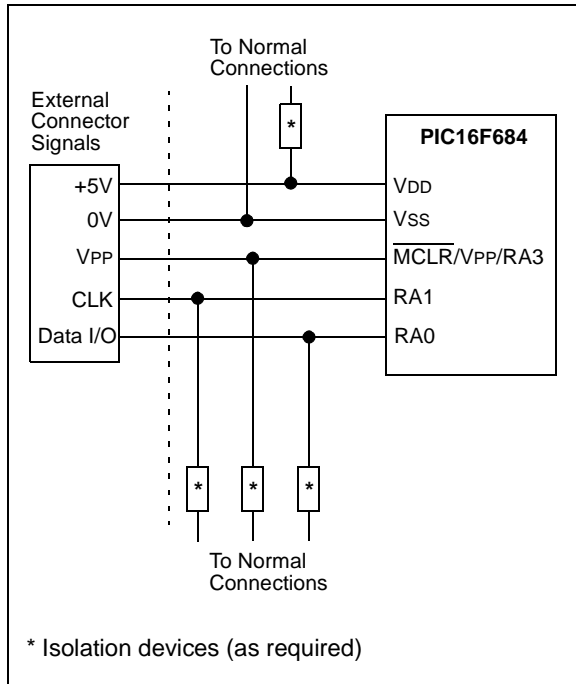

12.11 In-Circuit Debugger

Since in-circuit debugging requires access to the data and $\overline{\text{MCLR}}$ pins, MPLAB[®] ICD 2 development with an 14-pin device is not practical. A special 20-pin PIC16F684 ICD device is used with MPLAB ICD 2 to provide separate clock, data and $\overline{\text{MCLR}}$ pins and frees all normally available pins to the user.

A special debugging adapter allows the ICD device to be used in place of a PIC16F684 device. The debugging adapter is the only source of the ICD device.

When the $\overline{\text{ICD}}$ pin on the PIC16F684 ICD device is held low, the In-Circuit Debugger functionality is enabled. This function allows simple debugging functions when used with MPLAB ICD 2. When the microcontroller has this feature enabled, some of the resources are not available for general use. Table 12-9 shows which features are consumed by the background debugger.

TABLE 12-9: DEBUGGER RESOURCES

Resource	Description
I/O pins	ICDCLK, ICDDATA
Stack	1 level
Program Memory	Address 0h must be NOP 700h-7FFh

For more information, see "MPLAB[®] ICD 2 In-Circuit Debugger User's Guide" (DS51331), available on Microchip's web site (www.microchip.com).

FIGURE 12-12: 20-PIN ICD PINOUT

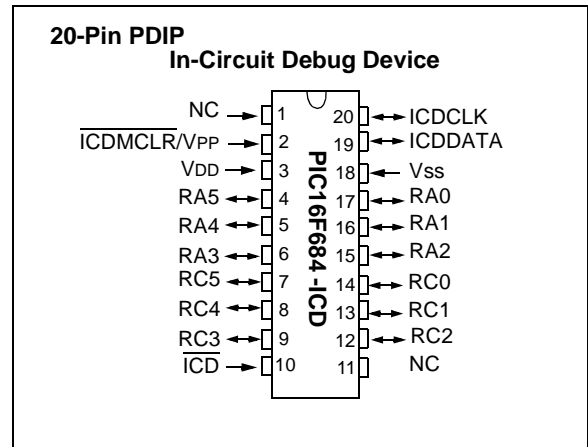

PIC16F684

NOTES:

13.0 INSTRUCTION SET SUMMARY

The PIC16F684 instruction set is highly orthogonal and is comprised of three basic categories:

- **Byte-oriented** operations
- **Bit-oriented** operations
- **Literal and control** operations

Each PIC16 instruction is a 14-bit word divided into an **opcode**, which specifies the instruction type and one or more **operands**, which further specify the operation of the instruction. The formats for each of the categories is presented in Figure 13-1, while the various opcode fields are summarized in Table 13-1.

Table 13-2 lists the instructions recognized by the MPASM™ assembler. A complete description of each instruction is also available in the “PICmicro® Mid-Range MCU Family Reference Manual” (DS33023).

For **byte-oriented** instructions, ‘f’ represents a file register designator and ‘d’ represents a destination designator. The file register designator specifies which file register is to be used by the instruction.

The destination designator specifies where the result of the operation is to be placed. If ‘d’ is zero, the result is placed in the W register. If ‘d’ is one, the result is placed in the file register specified in the instruction.

For **bit-oriented** instructions, ‘b’ represents a bit field designator, which selects the bit affected by the operation, while ‘f’ represents the address of the file in which the bit is located.

For **literal and control** operations, ‘k’ represents an 8-bit or 11-bit constant, or literal value.

One instruction cycle consists of four oscillator periods; for an oscillator frequency of 4 MHz, this gives a normal instruction execution time of 1 μs. All instructions are executed within a single instruction cycle, unless a conditional test is true, or the program counter is changed as a result of an instruction. When this occurs, the execution takes two instruction cycles, with the second cycle executed as a NOP.

Note: To maintain upward compatibility with future products, do not use the `OPTION` and `TRIS` instructions.

All instruction examples use the format ‘0xhh’ to represent a hexadecimal number, where ‘h’ signifies a hexadecimal digit.

13.1 READ-MODIFY-WRITE OPERATIONS

Any instruction that specifies a file register as part of the instruction performs a Read-Modify-Write (R-M-W) operation. The register is read, the data is modified, and the result is stored according to either the instruction, or the destination designator ‘d’. A read operation is performed on a register even if the instruction writes to that register.

For example, a `CLRF GPIO` instruction will read GPIO, clear all the data bits, then write the result back to GPIO. This example would have the unintended result of clearing the condition that set the GPIF flag.

TABLE 13-1: OPCODE FIELD DESCRIPTIONS

Field	Description
f	Register file address (0x00 to 0x7F)
W	Working register (accumulator)
b	Bit address within an 8-bit file register
k	Literal field, constant data or label
x	Don't care location (= 0 or 1). The assembler will generate code with x = 0. It is the recommended form of use for compatibility with all Microchip software tools.
d	Destination select; d = 0: store result in W, d = 1: store result in file register f. Default is d = 1.
PC	Program Counter
TO	Time-out bit
PD	Power-down bit

FIGURE 13-1: GENERAL FORMAT FOR INSTRUCTIONS

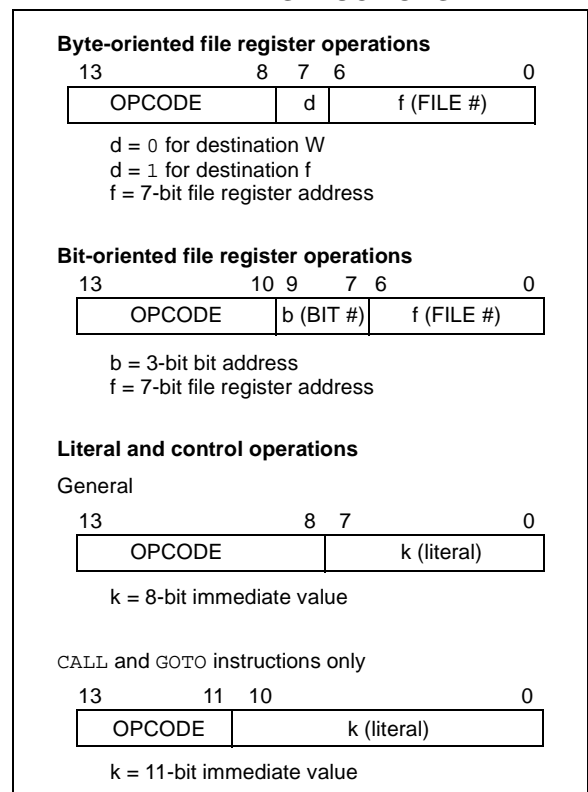

PIC16F684

TABLE 13-2: PIC16F684 INSTRUCTION SET

Mnemonic, Operands	Description	Cycles	14-Bit Opcode				Status Affected	Notes	
			MSb	LSb					
BYTE-ORIENTED FILE REGISTER OPERATIONS									
ADDWF	f, d	Add W and f	1	00	0111	dfff	ffff	C, DC, Z	1, 2
ANDWF	f, d	AND W with f	1	00	0101	dfff	ffff	Z	1, 2
CLRF	f	Clear f	1	00	0001	1fff	ffff	Z	2
CLRWF	–	Clear W	1	00	0001	0xxx	xxxx	Z	
COMF	f, d	Complement f	1	00	1001	dfff	ffff	Z	1, 2
DECf	f, d	Decrement f	1	00	0011	dfff	ffff	Z	1, 2
DECFSZ	f, d	Decrement f, Skip if 0	1(2)	00	1011	dfff	ffff		1, 2, 3
INCF	f, d	Increment f	1	00	1010	dfff	ffff	Z	1, 2
INCFSZ	f, d	Increment f, Skip if 0	1(2)	00	1111	dfff	ffff		1, 2, 3
IORWF	f, d	Inclusive OR W with f	1	00	0100	dfff	ffff	Z	1, 2
MOVF	f, d	Move f	1	00	1000	dfff	ffff	Z	1, 2
MOVWF	f	Move W to f	1	00	0000	1fff	ffff		
NOP	–	No Operation	1	00	0000	0xx0	0000		
RLF	f, d	Rotate Left f through Carry	1	00	1101	dfff	ffff	C	1, 2
RRF	f, d	Rotate Right f through Carry	1	00	1100	dfff	ffff	C	1, 2
SUBWF	f, d	Subtract W from f	1	00	0010	dfff	ffff	C, DC, Z	1, 2
SWAPF	f, d	Swap nibbles in f	1	00	1110	dfff	ffff		1, 2
XORWF	f, d	Exclusive OR W with f	1	00	0110	dfff	ffff	Z	1, 2
BIT-ORIENTED FILE REGISTER OPERATIONS									
BCF	f, b	Bit Clear f	1	01	00bb	bfff	ffff		1, 2
BSF	f, b	Bit Set f	1	01	01bb	bfff	ffff		1, 2
BTFSC	f, b	Bit Test f, Skip if Clear	1(2)	01	10bb	bfff	ffff		3
BTFSS	f, b	Bit Test f, Skip if Set	1(2)	01	11bb	bfff	ffff		3
LITERAL AND CONTROL OPERATIONS									
ADDLW	k	Add literal and W	1	11	111x	kkkk	kkkk	C, DC, Z	
ANDLW	k	AND literal with W	1	11	1001	kkkk	kkkk	Z	
CALL	k	Call Subroutine	2	10	0kkk	kkkk	kkkk		
CLRWD _T	–	Clear Watchdog Timer	1	00	0000	0110	0100	\overline{TO} , PD	
GOTO	k	Go to address	2	10	1kkk	kkkk	kkkk		
IORLW	k	Inclusive OR literal with W	1	11	1000	kkkk	kkkk	Z	
MOVLW	k	Move literal to W	1	11	00xx	kkkk	kkkk		
RETFIE	–	Return from interrupt	2	00	0000	0000	1001		
RETLW	k	Return with literal in W	2	11	01xx	kkkk	kkkk		
RETURN	–	Return from Subroutine	2	00	0000	0000	1000		
SLEEP	–	Go into Standby mode	1	00	0000	0110	0011	\overline{TO} , PD	
SUBLW	k	Subtract W from literal	1	11	110x	kkkk	kkkk	C, DC, Z	
XORLW	k	Exclusive OR literal with W	1	11	1010	kkkk	kkkk	Z	

- Note 1:** When an I/O register is modified as a function of itself (e.g., `MOVf GPIO, 1`), the value used will be that value present on the pins themselves. For example, if the data latch is '1' for a pin configured as input and is driven low by an external device, the data will be written back with a '0'.
- 2:** If this instruction is executed on the TMR0 register (and where applicable, d = 1), the prescaler will be cleared if assigned to the Timer0 module.
- 3:** If the Program Counter (PC) is modified, or a conditional test is true, the instruction requires two cycles. The second cycle is executed as a NOP.

Note: Additional information on the mid-range instruction set is available in the "PICmicro® Mid-Range MCU Family Reference Manual" (DS33023).

13.2 Instruction Descriptions

ADDLW **Add literal and W**

Syntax: [*label*] ADDLW *k*

Operands: $0 \leq k \leq 255$

Operation: $(W) + k \rightarrow (W)$

Status Affected: C, DC, Z

Description: The contents of the W register are added to the eight-bit literal 'k' and the result is placed in the W register.

BCF **Bit Clear f**

Syntax: [*label*] BCF *f*,*b*

Operands: $0 \leq f \leq 127$
 $0 \leq b \leq 7$

Operation: $0 \rightarrow (f)$

Status Affected: None

Description: Bit 'b' in register 'f' is cleared.

ADDWF **Add W and f**

Syntax: [*label*] ADDWF *f*,*d*

Operands: $0 \leq f \leq 127$
 $d \in [0,1]$

Operation: $(W) + (f) \rightarrow (\text{destination})$

Status Affected: C, DC, Z

Description: Add the contents of the W register with register 'f'. If 'd' is '0', the result is stored in the W register. If 'd' is '1', the result is stored back in register 'f'.

BSF **Bit Set f**

Syntax: [*label*] BSF *f*,*b*

Operands: $0 \leq f \leq 127$
 $0 \leq b \leq 7$

Operation: $1 \rightarrow (f)$

Status Affected: None

Description: Bit 'b' in register 'f' is set.

ANDLW **AND literal with W**

Syntax: [*label*] ANDLW *k*

Operands: $0 \leq k \leq 255$

Operation: $(W) .\text{AND.} (k) \rightarrow (W)$

Status Affected: Z

Description: The contents of W register are AND'ed with the eight-bit literal 'k'. The result is placed in the W register.

BTFSC **Bit Test, Skip if Clear**

Syntax: [*label*] BTFSC *f*,*b*

Operands: $0 \leq f \leq 127$
 $0 \leq b \leq 7$

Operation: skip if $(f) = 0$

Status Affected: None

Description: If bit 'b' in register 'f' is '1', the next instruction is executed.
If bit 'b', in register 'f', is '0', the next instruction is discarded, and a NOP is executed instead, making this a 2-cycle instruction.

ANDWF **AND W with f**

Syntax: [*label*] ANDWF *f*,*d*

Operands: $0 \leq f \leq 127$
 $d \in [0,1]$

Operation: $(W) .\text{AND.} (f) \rightarrow (\text{destination})$

Status Affected: Z

Description: AND the W register with register 'f'. If 'd' is '0', the result is stored in the W register. If 'd' is '1', the result is stored back in register 'f'.

PIC16F684

BTFSF **Bit Test f, Skip if Set**

Syntax: [*label*] BTFSF f,b
Operands: $0 \leq f \leq 127$
 $0 \leq b < 7$
Operation: skip if (f) = 1
Status Affected: None
Description: If bit 'b' in register 'f' is '0', the next instruction is executed.
 If bit 'b' is '1', then the next instruction is discarded and a NOP is executed instead, making this a 2-cycle instruction.

CLRWDT **Clear Watchdog Timer**

Syntax: [*label*] CLRWDT
Operands: None
Operation: 00h → WDT
 0 → WDT prescaler,
 1 → \overline{TO}
 1 → PD
Status Affected: \overline{TO} , PD
Description: CLRWDT instruction resets the Watchdog Timer. It also resets the prescaler of the WDT. Status bits \overline{TO} and PD are set.

CALL **Call Subroutine**

Syntax: [*label*] CALL k
Operands: $0 \leq k \leq 2047$
Operation: (PC)+1 → TOS,
 k → PC<10:0>,
 (PCLATH<4:3>) → PC<12:11>
Status Affected: None
Description: Call Subroutine. First, return address (PC + 1) is pushed onto the stack. The eleven-bit immediate address is loaded into PC bits <10:0>. The upper bits of the PC are loaded from PCLATH. CALL is a two-cycle instruction.

COMF **Complement f**

Syntax: [*label*] COMF f,d
Operands: $0 \leq f \leq 127$
 $d \in [0,1]$
Operation: (\bar{f}) → (destination)
Status Affected: Z
Description: The contents of register 'f' are complemented. If 'd' is '0', the result is stored in W. If 'd' is '1', the result is stored back in register 'f'.

CLRF **Clear f**

Syntax: [*label*] CLRF f
Operands: $0 \leq f \leq 127$
Operation: 00h → (f)
 1 → Z
Status Affected: Z
Description: The contents of register 'f' are cleared and the Z bit is set.

DECF **Decrement f**

Syntax: [*label*] DECF f,d
Operands: $0 \leq f \leq 127$
 $d \in [0,1]$
Operation: (f) - 1 → (destination)
Status Affected: Z
Description: Decrement register 'f'. If 'd' is '0', the result is stored in the W register. If 'd' is '1', the result is stored back in register 'f'.

CLRW **Clear W**

Syntax: [*label*] CLRW
Operands: None
Operation: 00h → (W)
 1 → Z
Status Affected: Z
Description: W register is cleared. Zero bit (Z) is set.

DECFSZ Decrement f, Skip if 0

Syntax: [*label*] DECFSZ f,d

Operands: $0 \leq f \leq 127$
 $d \in [0,1]$

Operation: (f) - 1 → (destination);
 skip if result = 0

Status Affected: None

Description: The contents of register 'f' are decremented. If 'd' is '0', the result is placed in the W register. If 'd' is '1', the result is placed back in register 'f'.
 If the result is '1', the next instruction is executed. If the result is '0', then a NOP is executed instead, making it a 2-cycle instruction.

INCFSZ Increment f, Skip if 0

Syntax: [*label*] INCFSZ f,d

Operands: $0 \leq f \leq 127$
 $d \in [0,1]$

Operation: (f) + 1 → (destination),
 skip if result = 0

Status Affected: None

Description: The contents of register 'f' are incremented. If 'd' is '0', the result is placed in the W register. If 'd' is '1', the result is placed back in register 'f'.
 If the result is '1', the next instruction is executed. If the result is '0', a NOP is executed instead, making it a 2-cycle instruction.

GOTO Unconditional Branch

Syntax: [*label*] GOTO k

Operands: $0 \leq k \leq 2047$

Operation: $k \rightarrow PC<10:0>$
 $PCLATH<4:3> \rightarrow PC<12:11>$

Status Affected: None

Description: GOTO is an unconditional branch. The eleven-bit immediate value is loaded into PC bits <10:0>. The upper bits of PC are loaded from PCLATH<4:3>. GOTO is a two-cycle instruction.

IORLW Inclusive OR literal with W

Syntax: [*label*] IORLW k

Operands: $0 \leq k \leq 255$

Operation: (W) .OR. k → (W)

Status Affected: Z

Description: The contents of the W register are OR'ed with the eight-bit literal 'k'. The result is placed in the W register.

INCF Increment f

Syntax: [*label*] INCF f,d

Operands: $0 \leq f \leq 127$
 $d \in [0,1]$

Operation: (f) + 1 → (destination)

Status Affected: Z

Description: The contents of register 'f' are incremented. If 'd' is '0', the result is placed in the W register. If 'd' is '1', the result is placed back in register 'f'.

IORWF Inclusive OR W with f

Syntax: [*label*] IORWF f,d

Operands: $0 \leq f \leq 127$
 $d \in [0,1]$

Operation: (W) .OR. (f) → (destination)

Status Affected: Z

Description: Inclusive OR the W register with register 'f'. If 'd' is '0', the result is placed in the W register. If 'd' is '1', the result is placed back in register 'f'.

PIC16F684

MOVF	Move f
Syntax:	[<i>label</i>] MOVF f,d
Operands:	$0 \leq f \leq 127$ $d \in [0,1]$
Operation:	(f) → (dest)
Status Affected:	Z
Description:	The contents of register f is moved to a destination dependent upon the status of d. If d = 0, destination is W register. If d = 1, the destination is file register f itself. d = 1 is useful to test a file register since status flag Z is affected.
Words:	1
Cycles:	1
<u>Example</u>	MOVF FSR, 0 After Instruction W = value in FSR register Z = 1

MOVLW	Move literal to W
Syntax:	[<i>label</i>] MOVLW k
Operands:	$0 \leq k \leq 255$
Operation:	k → (W)
Status Affected:	None
Description:	The eight bit literal 'k' is loaded into W register. The don't cares will assemble as '0's.
Words:	1
Cycles:	1
<u>Example</u>	MOVLW 0x5A After Instruction W = 0x5A

MOVWF	Move W to f
Syntax:	[<i>label</i>] MOVWF f
Operands:	$0 \leq f \leq 127$
Operation:	(W) → (f)
Status Affected:	None
Description:	Move data from W register to register 'f'.
Words:	1
Cycles:	1
<u>Example</u>	MOVW OPTION F Before Instruction OPTION = 0xFF W = 0x4F After Instruction OPTION = 0x4F W = 0x4F

NOP	No Operation
Syntax:	[<i>label</i>] NOP
Operands:	None
Operation:	No operation
Status Affected:	None
Description:	No operation.
Words:	1
Cycles:	1
<u>Example</u>	NOP

RETFIE **Return from Interrupt**

Syntax: [*label*] RETFIE

Operands: None

Operation: TOS → PC,
 1 → GIE

Status Affected: None

Description: Return from Interrupt. Stack is POPed and Top-of-Stack (TOS) is loaded in the PC. Interrupts are enabled by setting Global Interrupt Enable bit, GIE (INTCON<7>). This is a two-cycle instruction.

Words: 1

Cycles: 2

Example RETFIE

 After Interrupt

 PC = TOS

 GIE = 1

RETURN **Return from Subroutine**

Syntax: [*label*] RETURN

Operands: None

Operation: TOS → PC

Status Affected: None

Description: Return from subroutine. The stack is POPed and the top of the stack (TOS) is loaded into the program counter. This is a two-cycle instruction.

RETLW **Return with literal in W**

Syntax: [*label*] RETLW k

Operands: 0 ≤ k ≤ 255

Operation: k → (W);
 TOS → PC

Status Affected: None

Description: The W register is loaded with the eight bit literal 'k'. The program counter is loaded from the top of the stack (the return address). This is a two-cycle instruction.

Words: 1

Cycles: 2

Example CALL TABLE;W contains table

 ;offset value

TABLE • ;W now has table value

 •

 •

 ADDWF PC ;W = offset

 RETLW k1 ;Begin table

 RETLW k2 ;

 •

 •

 •

 RETLW kn ; End of table

 Before Instruction

 W = 0x07

 After Instruction

 W = value of k8

RLF **Rotate Left f through Carry**

Syntax: [*label*] RLF f,d

Operands: 0 ≤ f ≤ 127
 d ∈ [0,1]

Operation: See description below

Status Affected: C

Description: The contents of register 'f' are rotated one bit to the left through the Carry flag. If 'd' is '0', the result is placed in the W register. If 'd' is '1', the result is stored back in register 'f'.

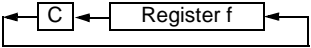

Words: 1

Cycles: 1

Example RLF REG1,0

Before Instruction

 REG1 = 1110 0110

 C = 0

After Instruction

 REG1 = 1110 0110

 W = 1100 1100

 C = 1

PIC16F684

RRF Rotate Right f through Carry

Syntax: [*label*] RRF f,d
Operands: $0 \leq f \leq 127$
 $d \in [0,1]$
Operation: See description below
Status Affected: C
Description: The contents of register 'f' are rotated one bit to the right through the Carry flag. If 'd' is '0', the result is placed in the W register. If 'd' is '1', the result is placed back in register 'f'.

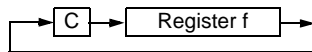

SUBWF Subtract W from f

Syntax: [*label*] SUBWF f,d
Operands: $0 \leq f \leq 127$
 $d \in [0,1]$
Operation: $(f) - (W) \rightarrow (\text{destination})$
Status Affected: C, DC, Z
Description: Subtract (2's complement method) W register from register 'f'. If 'd' is '0', the result is stored in the W register. If 'd' is '1', the result is stored back in register 'f'.

SLEEP Enter Sleep mode

Syntax: [*label*] SLEEP
Operands: None
Operation: $00h \rightarrow \text{WDT}$,
 $0 \rightarrow \text{WDT prescaler}$,
 $1 \rightarrow \overline{\text{TO}}$,
 $0 \rightarrow \text{PD}$
Status Affected: $\overline{\text{TO}}$, PD
Description: The power-down Status bit, PD is cleared. Time-out Status bit, $\overline{\text{TO}}$ is set. Watchdog Timer and its prescaler are cleared. The processor is put into Sleep mode with the oscillator stopped.

SWAPF Swap Nibbles in f

Syntax: [*label*] SWAPF f,d
Operands: $0 \leq f \leq 127$
 $d \in [0,1]$
Operation: $(f<3:0>) \rightarrow (\text{destination}<7:4>)$,
 $(f<7:4>) \rightarrow (\text{destination}<3:0>)$
Status Affected: None
Description: The upper and lower nibbles of register 'f' are exchanged. If 'd' is '0', the result is placed in the W register. If 'd' is '1', the result is placed in register 'f'.

SUBLW Subtract W from literal

Syntax: [*label*] SUBLW k
Operands: $0 \leq k \leq 255$
Operation: $k - (W) \rightarrow (W)$
Status Affected: C, DC, Z
Description: The W register is subtracted (2's complement method) from the eight-bit literal 'k'. The result is placed in the W register.

XORLW Exclusive OR literal with W

Syntax: [*label*] XORLW k
Operands: $0 \leq k \leq 255$
Operation: $(W) .\text{XOR} .k \rightarrow (W)$
Status Affected: Z
Description: The contents of the W register are XOR'ed with the eight-bit literal 'k'. The result is placed in the W register.

XORWF Exclusive OR W with f

Syntax: [*label*] XORWF f,d

Operands: $0 \leq f \leq 127$
 $d \in [0,1]$

Operation: (W) .XOR. (f) \rightarrow (destination)

Status Affected: Z

Description: Exclusive OR the contents of the W register with register 'f'. If 'd' is '0', the result is stored in the W register. If 'd' is '1', the result is stored back in register 'f'.

PIC16F684

NOTES:

14.0 DEVELOPMENT SUPPORT

The PICmicro® microcontrollers are supported with a full range of hardware and software development tools:

- Integrated Development Environment
 - MPLAB® IDE Software
- Assemblers/Compilers/Linkers
 - MPASM™ Assembler
 - MPLAB C17 and MPLAB C18 C Compilers
 - MPLINK™ Object Linker/
MPLIB™ Object Librarian
 - MPLAB C30 C Compiler
 - MPLAB ASM30 Assembler/Linker/Library
- Simulators
 - MPLAB SIM Software Simulator
 - MPLAB dsPIC30 Software Simulator
- Emulators
 - MPLAB ICE 2000 In-Circuit Emulator
 - MPLAB ICE 4000 In-Circuit Emulator
- In-Circuit Debugger
 - MPLAB ICD 2
- Device Programmers
 - PRO MATE® II Universal Device Programmer
 - PICSTART® Plus Development Programmer
 - MPLAB PM3 Device Programmer
- Low-Cost Demonstration Boards
 - PICDEM™ 1 Demonstration Board
 - PICDEM.net™ Demonstration Board
 - PICDEM 2 Plus Demonstration Board
 - PICDEM 3 Demonstration Board
 - PICDEM 4 Demonstration Board
 - PICDEM 17 Demonstration Board
 - PICDEM 18R Demonstration Board
 - PICDEM LIN Demonstration Board
 - PICDEM USB Demonstration Board
- Evaluation Kits
 - KEELQ®
 - PICDEM MSC
 - microID®
 - CAN
 - PowerSmart®
 - Analog

14.1 MPLAB Integrated Development Environment Software

The MPLAB IDE software brings an ease of software development previously unseen in the 8/16-bit microcontroller market. The MPLAB IDE is a Windows® based application that contains:

- An interface to debugging tools
 - simulator
 - programmer (sold separately)
 - emulator (sold separately)
 - in-circuit debugger (sold separately)
- A full-featured editor with color coded context
- A multiple project manager
- Customizable data windows with direct edit of contents
- High-level source code debugging
- Mouse over variable inspection
- Extensive on-line help

The MPLAB IDE allows you to:

- Edit your source files (either assembly or C)
- One touch assemble (or compile) and download to PICmicro emulator and simulator tools (automatically updates all project information)
- Debug using:
 - source files (assembly or C)
 - mixed assembly and C
 - machine code

MPLAB IDE supports multiple debugging tools in a single development paradigm, from the cost effective simulators, through low-cost in-circuit debuggers, to full-featured emulators. This eliminates the learning curve when upgrading to tools with increasing flexibility and power.

14.2 MPASM Assembler

The MPASM assembler is a full-featured, universal macro assembler for all PICmicro MCUs.

The MPASM assembler generates relocatable object files for the MPLINK object linker, Intel® standard HEX files, MAP files to detail memory usage and symbol reference, absolute LST files that contain source lines and generated machine code and COFF files for debugging.

The MPASM assembler features include:

- Integration into MPLAB IDE projects
- User defined macros to streamline assembly code
- Conditional assembly for multi-purpose source files
- Directives that allow complete control over the assembly process

PIC16F684

14.3 MPLAB C17 and MPLAB C18 C Compilers

The MPLAB C17 and MPLAB C18 Code Development Systems are complete ANSI C compilers for Microchip's PIC17CXXX and PIC18CXXX family of microcontrollers. These compilers provide powerful integration capabilities, superior code optimization and ease of use not found with other compilers.

For easy source level debugging, the compilers provide symbol information that is optimized to the MPLAB IDE debugger.

14.4 MPLINK Object Linker/ MPLIB Object Librarian

The MPLINK object linker combines relocatable objects created by the MPASM assembler and the MPLAB C17 and MPLAB C18 C compilers. It can link relocatable objects from precompiled libraries, using directives from a linker script.

The MPLIB object librarian manages the creation and modification of library files of precompiled code. When a routine from a library is called from a source file, only the modules that contain that routine will be linked in with the application. This allows large libraries to be used efficiently in many different applications.

The object linker/librarian features include:

- Efficient linking of single libraries instead of many smaller files
- Enhanced code maintainability by grouping related modules together
- Flexible creation of libraries with easy module listing, replacement, deletion and extraction

14.5 MPLAB C30 C Compiler

The MPLAB C30 C compiler is a full-featured, ANSI compliant, optimizing compiler that translates standard ANSI C programs into dsPIC30F assembly language source. The compiler also supports many command line options and language extensions to take full advantage of the dsPIC30F device hardware capabilities and afford fine control of the compiler code generator.

MPLAB C30 is distributed with a complete ANSI C standard library. All library functions have been validated and conform to the ANSI C library standard. The library includes functions for string manipulation, dynamic memory allocation, data conversion, time-keeping and math functions (trigonometric, exponential and hyperbolic). The compiler provides symbolic information for high-level source debugging with the MPLAB IDE.

14.6 MPLAB ASM30 Assembler, Linker and Librarian

MPLAB ASM30 assembler produces relocatable machine code from symbolic assembly language for dsPIC30F devices. MPLAB C30 compiler uses the assembler to produce its object file. The assembler generates relocatable object files that can then be archived or linked with other relocatable object files and archives to create an executable file. Notable features of the assembler include:

- Support for the entire dsPIC30F instruction set
- Support for fixed-point and floating-point data
- Command line interface
- Rich directive set
- Flexible macro language
- MPLAB IDE compatibility

14.7 MPLAB SIM Software Simulator

The MPLAB SIM software simulator allows code development in a PC hosted environment by simulating the PICmicro series microcontrollers on an instruction level. On any given instruction, the data areas can be examined or modified and stimuli can be applied from a file, or user defined key press, to any pin. The execution can be performed in Single-Step, Execute Until Break or Trace mode.

The MPLAB SIM simulator fully supports symbolic debugging using the MPLAB C17 and MPLAB C18 C Compilers, as well as the MPASM assembler. The software simulator offers the flexibility to develop and debug code outside of the laboratory environment, making it an excellent, economical software development tool.

14.8 MPLAB SIM30 Software Simulator

The MPLAB SIM30 software simulator allows code development in a PC hosted environment by simulating the dsPIC30F series microcontrollers on an instruction level. On any given instruction, the data areas can be examined or modified and stimuli can be applied from a file, or user defined key press, to any of the pins.

The MPLAB SIM30 simulator fully supports symbolic debugging using the MPLAB C30 C Compiler and MPLAB ASM30 assembler. The simulator runs in either a Command Line mode for automated tasks, or from MPLAB IDE. This high-speed simulator is designed to debug, analyze and optimize time intensive DSP routines.

14.9 MPLAB ICE 2000 High-Performance Universal In-Circuit Emulator

The MPLAB ICE 2000 universal in-circuit emulator is intended to provide the product development engineer with a complete microcontroller design tool set for PICmicro microcontrollers. Software control of the MPLAB ICE 2000 in-circuit emulator is advanced by the MPLAB Integrated Development Environment, which allows editing, building, downloading and source debugging from a single environment.

The MPLAB ICE 2000 is a full-featured emulator system with enhanced trace, trigger and data monitoring features. Interchangeable processor modules allow the system to be easily reconfigured for emulation of different processors. The universal architecture of the MPLAB ICE in-circuit emulator allows expansion to support new PICmicro microcontrollers.

The MPLAB ICE 2000 in-circuit emulator system has been designed as a real-time emulation system with advanced features that are typically found on more expensive development tools. The PC platform and Microsoft® Windows 32-bit operating system were chosen to best make these features available in a simple, unified application.

14.10 MPLAB ICE 4000 High-Performance Universal In-Circuit Emulator

The MPLAB ICE 4000 universal in-circuit emulator is intended to provide the product development engineer with a complete microcontroller design tool set for high-end PICmicro microcontrollers. Software control of the MPLAB ICE in-circuit emulator is provided by the MPLAB Integrated Development Environment, which allows editing, building, downloading and source debugging from a single environment.

The MPLAB ICE 4000 is a premium emulator system, providing the features of MPLAB ICE 2000, but with increased emulation memory and high-speed performance for dsPIC30F and PIC18XXXX devices. Its advanced emulator features include complex triggering and timing, up to 2 Mb of emulation memory and the ability to view variables in real-time.

The MPLAB ICE 4000 in-circuit emulator system has been designed as a real-time emulation system with advanced features that are typically found on more expensive development tools. The PC platform and Microsoft Windows 32-bit operating system were chosen to best make these features available in a simple, unified application.

14.11 MPLAB ICD 2 In-Circuit Debugger

Microchip's In-Circuit Debugger, MPLAB ICD 2, is a powerful, low-cost, run-time development tool, connecting to the host PC via an RS-232 or high-speed USB interface. This tool is based on the Flash PICmicro MCUs and can be used to develop for these and other PICmicro microcontrollers. The MPLAB ICD 2 utilizes the in-circuit debugging capability built into the Flash devices. This feature, along with Microchip's In-Circuit Serial Programming™ (ICSP™) protocol, offers cost effective in-circuit Flash debugging from the graphical user interface of the MPLAB Integrated Development Environment. This enables a designer to develop and debug source code by setting breakpoints, single-stepping and watching variables, CPU status and peripheral registers. Running at full speed enables testing hardware and applications in real-time. MPLAB ICD 2 also serves as a development programmer for selected PICmicro devices.

14.12 PRO MATE II Universal Device Programmer

The PRO MATE II is a universal, CE compliant device programmer with programmable voltage verification at VDDMIN and VDDMAX for maximum reliability. It features an LCD display for instructions and error messages and a modular detachable socket assembly to support various package types. In Stand-Alone mode, the PRO MATE II device programmer can read, verify and program PICmicro devices without a PC connection. It can also set code protection in this mode.

14.13 MPLAB PM3 Device Programmer

The MPLAB PM3 is a universal, CE compliant device programmer with programmable voltage verification at VDDMIN and VDDMAX for maximum reliability. It features a large LCD display (128 x 64) for menus and error messages and a modular detachable socket assembly to support various package types. The ICSP™ cable assembly is included as a standard item. In Stand-Alone mode, the MPLAB PM3 device programmer can read, verify and program PICmicro devices without a PC connection. It can also set code protection in this mode. MPLAB PM3 connects to the host PC via an RS-232 or USB cable. MPLAB PM3 has high-speed communications and optimized algorithms for quick programming of large memory devices and incorporates an SD/MMC card for file storage and secure data applications.

PIC16F684

14.14 PICSTART Plus Development Programmer

The PICSTART Plus development programmer is an easy-to-use, low-cost, prototype programmer. It connects to the PC via a COM (RS-232) port. MPLAB Integrated Development Environment software makes using the programmer simple and efficient. The PICSTART Plus development programmer supports most PICmicro devices up to 40 pins. Larger pin count devices, such as the PIC16C92X and PIC17C76X, may be supported with an adapter socket. The PICSTART Plus development programmer is CE compliant.

14.15 PICDEM 1 PICmicro Demonstration Board

The PICDEM 1 demonstration board demonstrates the capabilities of the PIC16C5X (PIC16C54 to PIC16C58A), PIC16C61, PIC16C62X, PIC16C71, PIC16C8X, PIC17C42, PIC17C43 and PIC17C44. All necessary hardware and software is included to run basic demo programs. The sample microcontrollers provided with the PICDEM 1 demonstration board can be programmed with a PRO MATE II device programmer or a PICSTART Plus development programmer. The PICDEM 1 demonstration board can be connected to the MPLAB ICE in-circuit emulator for testing. A prototype area extends the circuitry for additional application components. Features include an RS-232 interface, a potentiometer for simulated analog input, push button switches and eight LEDs.

14.16 PICDEM.net Internet/Ethernet Demonstration Board

The PICDEM.net demonstration board is an Internet/Ethernet demonstration board using the PIC18F452 microcontroller and TCP/IP firmware. The board supports any 40-pin DIP device that conforms to the standard pinout used by the PIC16F877 or PIC18C452. This kit features a user friendly TCP/IP stack, web server with HTML, a 24L256 Serial EEPROM for Xmodem download to web pages into Serial EEPROM, ICSP/MPLAB ICD 2 interface connector, an Ethernet interface, RS-232 interface and a 16 x 2 LCD display. Also included is the book and CD-ROM "TCP/IP Lean, Web Servers for Embedded Systems," by Jeremy Bentham

14.17 PICDEM 2 Plus Demonstration Board

The PICDEM 2 Plus demonstration board supports many 18, 28 and 40-pin microcontrollers, including PIC16F87X and PIC18FXX2 devices. All the necessary hardware and software is included to run the demonstration programs. The sample microcontrollers provided with the PICDEM 2 demonstration board can be programmed with a PRO MATE II device programmer, PICSTART Plus development programmer, or MPLAB ICD 2 with a Universal Programmer Adapter. The MPLAB ICD 2 and MPLAB ICE in-circuit emulators may also be used with the PICDEM 2 demonstration board to test firmware. A prototype area extends the circuitry for additional application components. Some of the features include an RS-232 interface, a 2 x 16 LCD display, a piezo speaker, an on-board temperature sensor, four LEDs and sample PIC18F452 and PIC16F877 Flash microcontrollers.

14.18 PICDEM 3 PIC16C92X Demonstration Board

The PICDEM 3 demonstration board supports the PIC16C923 and PIC16C924 in the PLCC package. All the necessary hardware and software is included to run the demonstration programs.

14.19 PICDEM 4 8/14/18-Pin Demonstration Board

The PICDEM 4 can be used to demonstrate the capabilities of the 8, 14 and 18-pin PIC16XXXX and PIC18XXXX MCUs, including the PIC16F818/819, PIC16F87/88, PIC16F62XA and the PIC18F1320 family of microcontrollers. PICDEM 4 is intended to showcase the many features of these low pin count parts, including LIN and Motor Control using ECCP. Special provisions are made for low-power operation with the supercapacitor circuit and jumpers allow on-board hardware to be disabled to eliminate current draw in this mode. Included on the demo board are provisions for Crystal, RC or Canned Oscillator modes, a five volt regulator for use with a nine volt wall adapter or battery, DB-9 RS-232 interface, ICD connector for programming via ICSP and development with MPLAB ICD 2, 2 x 16 liquid crystal display, PCB footprints for H-bridge motor driver, LIN transceiver and EEPROM. Also included are: header for expansion, eight LEDs, four potentiometers, three push buttons and a prototyping area. Included with the kit is a PIC16F627A and a PIC18F1320. Tutorial firmware is included along with the User's Guide.

14.20 PICDEM 17 Demonstration Board

The PICDEM 17 demonstration board is an evaluation board that demonstrates the capabilities of several Microchip microcontrollers, including PIC17C752, PIC17C756A, PIC17C762 and PIC17C766. A programmed sample is included. The PRO MATE II device programmer, or the PICSTART Plus development programmer, can be used to reprogram the device for user tailored application development. The PICDEM 17 demonstration board supports program download and execution from external on-board Flash memory. A generous prototype area is available for user hardware expansion.

14.21 PICDEM 18R PIC18C601/801 Demonstration Board

The PICDEM 18R demonstration board serves to assist development of the PIC18C601/801 family of Microchip microcontrollers. It provides hardware implementation of both 8-bit Multiplexed/Demultiplexed and 16-bit Memory modes. The board includes 2 Mb external Flash memory and 128 Kb SRAM memory, as well as serial EEPROM, allowing access to the wide range of memory types supported by the PIC18C601/801.

14.22 PICDEM LIN PIC16C43X Demonstration Board

The powerful LIN hardware and software kit includes a series of boards and three PICmicro microcontrollers. The small footprint PIC16C432 and PIC16C433 are used as slaves in the LIN communication and feature on-board LIN transceivers. A PIC16F874 Flash microcontroller serves as the master. All three microcontrollers are programmed with firmware to provide LIN bus communication.

14.23 PICkit™ 1 Flash Starter Kit

A complete “development system in a box”, the PICkit Flash Starter Kit includes a convenient multi-section board for programming, evaluation and development of 8/14-pin Flash PIC® microcontrollers. Powered via USB, the board operates under a simple Windows GUI. The PICkit 1 Starter Kit includes the User’s Guide (on CD ROM), PICkit 1 tutorial software and code for various applications. Also included are MPLAB® IDE (Integrated Development Environment) software, software and hardware “Tips ‘n Tricks for 8-pin Flash PIC® Microcontrollers” Handbook and a USB interface cable. Supports all current 8/14-pin Flash PIC microcontrollers, as well as many future planned devices.

14.24 PICDEM USB PIC16C7X5 Demonstration Board

The PICDEM USB Demonstration Board shows off the capabilities of the PIC16C745 and PIC16C765 USB microcontrollers. This board provides the basis for future USB products.

14.25 Evaluation and Programming Tools

In addition to the PICDEM series of circuits, Microchip has a line of evaluation kits and demonstration software for these products.

- KEELOQ evaluation and programming tools for Microchip’s HCS Secure Data Products
- CAN developers kit for automotive network applications
- Analog design boards and filter design software
- PowerSmart battery charging evaluation/calibration kits
- IrDA® development kit
- microID development and rLab™ development software
- SEEVAL® designer kit for memory evaluation and endurance calculations
- PICDEM MSC demo boards for Switching mode power supply, high-power IR driver, delta sigma ADC and flow rate sensor

Check the Microchip web page and the latest Product Selector Guide for the complete list of demonstration and evaluation kits.

PIC16F684

NOTES:

15.0 ELECTRICAL SPECIFICATIONS

Absolute Maximum Ratings^(†)

Ambient temperature under bias	-40° to +125°C
Storage temperature	-65°C to +150°C
Voltage on VDD with respect to VSS	-0.3V to +6.5V
Voltage on $\overline{\text{MCLR}}$ with respect to VSS	-0.3V to +13.5V
Voltage on all other pins with respect to VSS	-0.3V to (VDD + 0.3V)
Total power dissipation ⁽¹⁾	800 mW
Maximum current out of VSS pin	300 mA
Maximum current into VDD pin	250 mA
Input clamp current, I _{IK} (V _I < 0 or V _I > VDD).....	± 20 mA
Output clamp current, I _{OK} (V _O < 0 or V _O > VDD).....	± 20 mA
Maximum output current sunk by any I/O pin.....	25 mA
Maximum output current sourced by any I/O pin	25 mA
Maximum current sunk by PORTA and PORTC (combined)	200 mA
Maximum current sourced PORTA and PORTC (combined).....	200 mA

Note 1: Power dissipation is calculated as follows: $P_{DIS} = V_{DD} \times \{I_{DD} - \sum I_{OH}\} + \sum \{(V_{DD} - V_{OH}) \times I_{OH}\} + \sum (V_{OL} \times I_{OL})$.

† NOTICE: Stresses above those listed under “Absolute Maximum Ratings” may cause permanent damage to the device. This is a stress rating only and functional operation of the device at those or any other conditions above those indicated in the operation listings of this specification is not implied. Exposure to maximum rating conditions for extended periods may affect device reliability.

Note: Voltage spikes below VSS at the $\overline{\text{MCLR}}$ pin, inducing currents greater than 80 mA, may cause latch-up. Thus, a series resistor of 50-100 Ω should be used when applying a “low” level to the $\overline{\text{MCLR}}$ pin, rather than pulling this pin directly to VSS.

PIC16F684

FIGURE 15-1: PIC16F684 VOLTAGE-FREQUENCY GRAPH, $-40^{\circ}\text{C} \leq T_A \leq +125^{\circ}\text{C}$

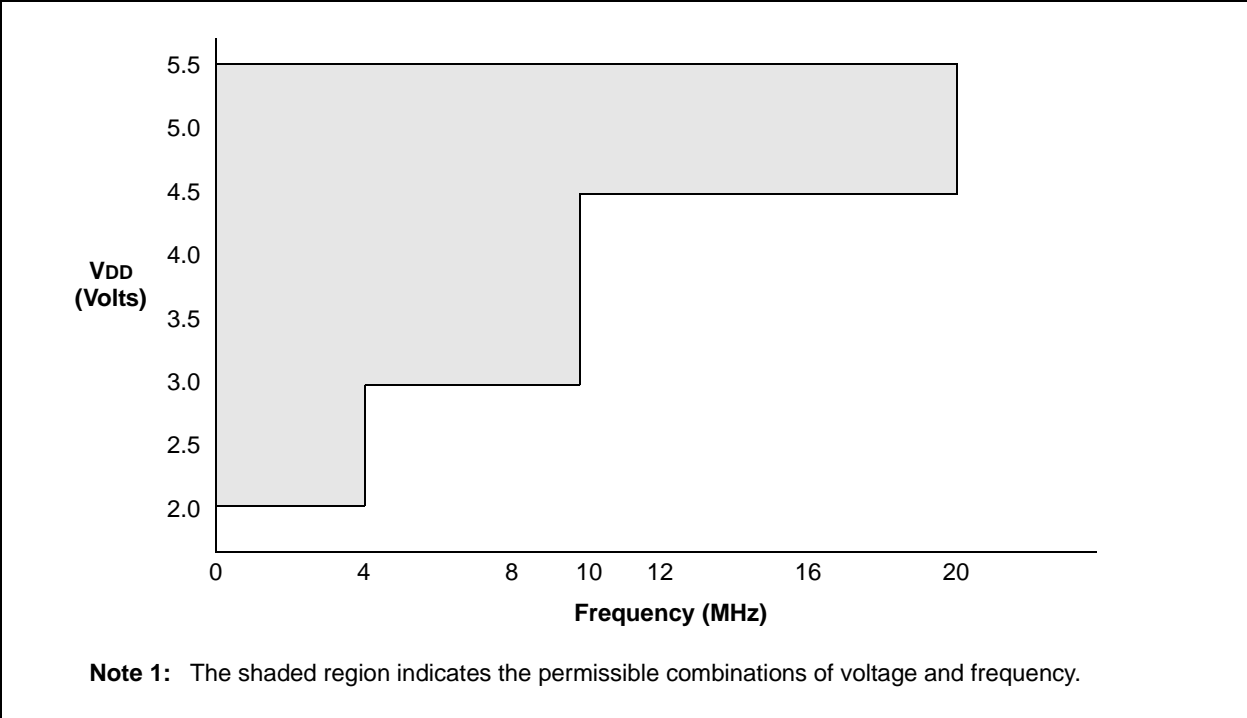

15.1 DC Characteristics: PIC16F684 -I (Industrial) PIC16F684 -E (Extended)

DC CHARACTERISTICS			Standard Operating Conditions (unless otherwise stated)				
			Operating temperature -40°C ≤ TA ≤ +85°C for industrial -40°C ≤ TA ≤ +125°C for extended				
Param No.	Sym	Characteristic	Min	Typ†	Max	Units	Conditions
D001 D001C D001D	VDD	Supply Voltage	2.0 3.0 4.5	—	5.5 5.5 5.5	V V V	FOSC ≤ 4 MHz: FOSC ≤ 10 MHz FOSC ≤ 20 MHz
D002	VDR	RAM Data Retention Voltage⁽¹⁾	1.5*	—	—	V	Device in Sleep mode
D003	VPOR	VDD Start Voltage to ensure internal Power-on Reset signal	—	VSS	—	V	See Section 12.3.3 “Power-On Reset (POR)” for details.
D004	SVDD	VDD Rise Rate to ensure internal Power-on Reset signal	0.05*	—	—	V/ms	See Section 12.3.3 “Power-On Reset (POR)” for details.
D005	VBOD	Brown-out Detect	—	2.1	—	V	

* These parameters are characterized but not tested.

† Data in “Typ” column is at 5.0V, 25°C unless otherwise stated. These parameters are for design guidance only and are not tested.

Note 1: This is the limit to which VDD can be lowered in Sleep mode without losing RAM data.

PIC16F684

15.2 DC Characteristics: PIC16F684-I (Industrial)

DC CHARACTERISTICS		Standard Operating Conditions (unless otherwise stated) Operating temperature $-40^{\circ}\text{C} \leq T_A \leq +85^{\circ}\text{C}$ for industrial					
Param No.	Device Characteristics	Min	Typ†	Max	Units	Conditions	
						VDD	Note
D010	Supply Current (IDD) ^(1, 2)	—	9	TBD	μA	2.0	Fosc = 32 kHz LP Oscillator mode
		—	18	TBD	μA	3.0	
		—	35	TBD	μA	5.0	
D011		—	110	TBD	μA	2.0	Fosc = 1 MHz XT Oscillator mode
		—	190	TBD	μA	3.0	
		—	330	TBD	μA	5.0	
D012		—	220	TBD	μA	2.0	Fosc = 4 MHz XT Oscillator mode
		—	370	TBD	μA	3.0	
		—	0.6	TBD	mA	5.0	
D013		—	70	TBD	μA	2.0	Fosc = 1 MHz EC Oscillator mode
		—	140	TBD	μA	3.0	
		—	260	TBD	μA	5.0	
D014		—	180	TBD	μA	2.0	Fosc = 4 MHz EC Oscillator mode
		—	320	TBD	μA	3.0	
		—	580	TBD	μA	5.0	
D015		—	TBD	TBD	μA	2.0	Fosc = 31 kHz INTRC mode
		—	TBD	TBD	μA	3.0	
		—	TBD	TBD	mA	5.0	
D016		—	340	TBD	μA	2.0	Fosc = 4 MHz INTOSC mode
		—	500	TBD	μA	3.0	
		—	0.8	TBD	mA	5.0	
D017		—	180	TBD	μA	2.0	Fosc = 4 MHz EXTRC mode
		—	320	TBD	μA	3.0	
		—	580	TBD	μA	5.0	
D018		—	2.1	TBD	mA	4.5	Fosc = 20 MHz HS Oscillator mode
		—	2.4	TBD	mA	5.0	

Legend: TBD = To Be Determined.

† Data in 'Typ' column is at 5.0V, 25°C unless otherwise stated. These parameters are for design guidance only and are not tested.

- Note 1:** The test conditions for all IDD measurements in active operation mode are: OSC1 = external square wave, from rail to rail; all I/O pins tri-stated, pulled to VDD; MCLR = VDD; WDT disabled.
- 2:** The supply current is mainly a function of the operating voltage and frequency. Other factors, such as I/O pin loading and switching rate, oscillator type, internal code execution pattern and temperature, also have an impact on the current consumption.
- 3:** The peripheral current is the sum of the base IDD or IPD and the additional current consumed when this peripheral is enabled. The peripheral Δ current can be determined by subtracting the base IDD or IPD current from this limit. Max values should be used when calculating total current consumption.
- 4:** The power-down current in Sleep mode does not depend on the oscillator type. Power-down current is measured with the part in Sleep mode, with all I/O pins in high-impedance state and tied to VDD.

15.2 DC Characteristics: PIC16F684-I (Industrial) (Continued)

DC CHARACTERISTICS		Standard Operating Conditions (unless otherwise stated) Operating temperature $-40^{\circ}\text{C} \leq T_A \leq +85^{\circ}\text{C}$ for industrial					
Param No.	Device Characteristics	Min	Typ†	Max	Units	Conditions	
						VDD	Note
D020	Power-down Base Current(IPD) ⁽⁴⁾	—	0.99	TBD	nA	2.0	WDT, BOD, Comparators, VREF and T1OSC disabled
		—	1.2	TBD	nA	3.0	
		—	2.9	TBD	nA	5.0	
D021		—	0.3	TBD	μA	2.0	WDT Current
		—	1.8	TBD	μA	3.0	
		—	8.4	TBD	μA	5.0	
D022		—	58	TBD	μA	3.0	BOD Current ⁽²⁾
		—	109	TBD	μA	5.0	
D023		—	3.3	TBD	μA	2.0	Comparator Current ⁽³⁾
		—	6.1	TBD	μA	3.0	
		—	11.5	TBD	μA	5.0	
D024		—	58	TBD	μA	2.0	CVREF Current ⁽¹⁾
		—	85	TBD	μA	3.0	
		—	138	TBD	μA	5.0	
D025		—	4.0	TBD	μA	2.0	T1OSC Current ⁽¹⁾
		—	4.6	TBD	μA	3.0	
		—	6.0	TBD	μA	5.0	
D026		—	1.2	TBD	nA	3.0	A/D Current ⁽¹⁾
		—	0.0022	TBD	μA	5.0	

Legend: TBD = To Be Determined.

† Data in 'Typ' column is at 5.0V, 25°C unless otherwise stated. These parameters are for design guidance only and are not tested.

- Note 1:** The test conditions for all IDD measurements in active operation mode are: OSC1 = external square wave, from rail to rail; all I/O pins tri-stated, pulled to VDD; MCLR = VDD; WDT disabled.
- 2:** The supply current is mainly a function of the operating voltage and frequency. Other factors, such as I/O pin loading and switching rate, oscillator type, internal code execution pattern and temperature, also have an impact on the current consumption.
- 3:** The peripheral current is the sum of the base IDD or IPD and the additional current consumed when this peripheral is enabled. The peripheral Δ current can be determined by subtracting the base IDD or IPD current from this limit. Max values should be used when calculating total current consumption.
- 4:** The power-down current in Sleep mode does not depend on the oscillator type. Power-down current is measured with the part in Sleep mode, with all I/O pins in high-impedance state and tied to VDD.

PIC16F684

15.3 DC Characteristics: PIC16F684-E (Extended)

DC CHARACTERISTICS		Standard Operating Conditions (unless otherwise stated) Operating temperature $-40^{\circ}\text{C} \leq T_A \leq +125^{\circ}\text{C}$ for extended					
Param No.	Device Characteristics	Min	Typ†	Max	Units	Conditions	
						VDD	Note
D010E	Supply Current (IDD)	—	9	TBD	μA	2.0	Fosc = 32 kHz
		—	18	TBD	μA	3.0	LP Oscillator mode
		—	35	TBD	μA	5.0	
D011E		—	110	TBD	μA	2.0	Fosc = 1 MHz
		—	190	TBD	μA	3.0	XT Oscillator mode
		—	330	TBD	μA	5.0	
D012E		—	220	TBD	μA	2.0	Fosc = 4 MHz
		—	370	TBD	μA	3.0	XT Oscillator mode
		—	0.6	TBD	mA	5.0	
D013E		—	70	TBD	μA	2.0	Fosc = 1 MHz
		—	140	TBD	μA	3.0	EC Oscillator mode
		—	260	TBD	μA	5.0	
D014E		—	180	TBD	μA	2.0	Fosc = 4 MHz
		—	320	TBD	μA	3.0	EC Oscillator mode
		—	580	TBD	μA	5.0	
D015E		—	TBD	TBD	μA	2.0	Fosc = 31 kHz
		—	TBD	TBD	μA	3.0	INTRC mode
		—	TBD	TBD	mA	5.0	
D016E		—	340	TBD	μA	2.0	Fosc = 4 MHz
		—	500	TBD	μA	3.0	INTOSC mode
		—	0.8	TBD	mA	5.0	
D017E		—	180	TBD	μA	2.0	Fosc = 4 MHz
		—	320	TBD	μA	3.0	EXTRC mode
		—	580	TBD	μA	5.0	
D018E		—	2.1	TBD	mA	4.5	Fosc = 20 MHz
		—	2.4	TBD	mA	5.0	HS Oscillator mode

Legend: TBD = To Be Determined.

† Data in 'Typ' column is at 5.0V, 25°C unless otherwise stated. These parameters are for design guidance only and are not tested.

- Note 1:** The test conditions for all IDD measurements in active operation mode are: OSC1 = external square wave, from rail to rail; all I/O pins tri-stated, pulled to VDD; MCLR = VDD; WDT disabled.
- 2:** The supply current is mainly a function of the operating voltage and frequency. Other factors, such as I/O pin loading and switching rate, oscillator type, internal code execution pattern and temperature, also have an impact on the current consumption.
- 3:** The peripheral current is the sum of the base IDD or IPD and the additional current consumed when this peripheral is enabled. The peripheral Δ current can be determined by subtracting the base IDD or IPD current from this limit. Max values should be used when calculating total current consumption.
- 4:** The power-down current in Sleep mode does not depend on the oscillator type. Power-down current is measured with the part in Sleep mode, with all I/O pins in high-impedance state and tied to VDD.

15.3 DC Characteristics: PIC16F684-E (Extended) (Continued)

DC CHARACTERISTICS		Standard Operating Conditions (unless otherwise stated) Operating temperature $-40^{\circ}\text{C} \leq T_A \leq +125^{\circ}\text{C}$ for extended					
Param No.	Device Characteristics	Min	Typ†	Max	Units	Conditions	
						VDD	Note
D020E	Power-down Base Current (IPD) ⁽⁴⁾	—	0.00099	TBD	μA	2.0	WDT, BOD, Comparators, VREF and T1OSC disabled
		—	0.0012	TBD	μA	3.0	
		—	0.0029	TBD	μA	5.0	
D021E		—	0.3	TBD	μA	2.0	WDT Current
		—	1.8	TBD	μA	3.0	
		—	8.4	TBD	μA	5.0	
D022E		—	58	TBD	μA	3.0	BOD Current
		—	109	TBD	μA	5.0	
D023E		—	3.3	TBD	μA	2.0	Comparator Current ⁽³⁾
		—	6.1	TBD	μA	3.0	
		—	11.5	TBD	μA	5.0	
D024E		—	58	TBD	μA	2.0	CVREF Current
		—	85	TBD	μA	3.0	
		—	138	TBD	μA	5.0	
D025E		—	4.0	TBD	μA	2.0	T1OSC Current
		—	4.6	TBD	μA	3.0	
		—	6.0	TBD	μA	5.0	
D026E		—	0.0012	TBD	μA	3.0	A/D Current ⁽³⁾
		—	0.0022	TBD	μA	5.0	

Legend: TBD = To Be Determined.

† Data in 'Typ' column is at 5.0V, 25°C unless otherwise stated. These parameters are for design guidance only and are not tested.

- Note 1:** The test conditions for all IDD measurements in active operation mode are: OSC1 = external square wave, from rail to rail; all I/O pins tri-stated, pulled to VDD; MCLR = VDD; WDT disabled.
- 2:** The supply current is mainly a function of the operating voltage and frequency. Other factors, such as I/O pin loading and switching rate, oscillator type, internal code execution pattern and temperature, also have an impact on the current consumption.
- 3:** The peripheral current is the sum of the base IDD or IPD and the additional current consumed when this peripheral is enabled. The peripheral Δ current can be determined by subtracting the base IDD or IPD current from this limit. Max values should be used when calculating total current consumption.
- 4:** The power-down current in Sleep mode does not depend on the oscillator type. Power-down current is measured with the part in Sleep mode, with all I/O pins in high-impedance state and tied to VDD.

PIC16F684

15.4 DC Characteristics: PIC16F684 -I (Industrial) PIC16F684 -E (Extended)

DC CHARACTERISTICS			Standard Operating Conditions (unless otherwise stated)				
			Operating temperature -40°C ≤ TA ≤ +85°C for industrial -40°C ≤ TA ≤ +125°C for extended				
Param No.	Sym	Characteristic	Min	Typ†	Max	Units	Conditions
D030 D030A D031 D032 D033 D033A	VIL	Input Low Voltage I/O port: with TTL buffer with Schmitt Trigger buffer <u>MCLR</u> , OSC1 (RC mode) OSC1 (XT and LP modes) ⁽¹⁾ OSC1 (HS mode) ⁽¹⁾	VSS VSS VSS VSS VSS VSS	— — — — — —	0.8 0.15 VDD 0.2 VDD 0.2 VDD 0.3 0.3 VDD	V V V V V V	4.5V ≤ VDD ≤ 5.5V Otherwise Entire range
D040 D040A D041 D042 D043 D043A D043B	VIH	Input High Voltage I/O ports: with TTL buffer with Schmitt Trigger buffer <u>MCLR</u> OSC1 (XT and LP modes) OSC1 (HS mode) OSC1 (RC mode)	2.0 (0.25 VDD + 0.8) 0.8 VDD 0.8 VDD 1.6 0.7 VDD 0.9 VDD	— — — — — — —	VDD VDD VDD VDD VDD VDD VDD	V V V V V V V	4.5V ≤ VDD ≤ 5.5V Otherwise Entire range (Note 1) (Note 1)
D070	IPUR	PORTA Weak Pull-up Current	50*	250	400*	μA	VDD = 5.0V, VPIN = VSS
D060 D061 D063	IIL	Input Leakage Current⁽²⁾ I/O ports <u>MCLR</u> ⁽³⁾ OSC1	— — —	± 0.1 ± 0.1 ± 0.1	± 1 ± 5 ± 5	μA μA μA	VSS ≤ VPIN ≤ VDD, Pin at high-impedance VSS ≤ VPIN ≤ VDD VSS ≤ VPIN ≤ VDD, XT, HS and LP oscillator configuration
D080 D083	VOL	Output Low Voltage I/O ports OSC2/CLKOUT (RC mode)	— —	— —	0.6 0.6	V V	IOL = 8.5 mA, VDD = 4.5V (Ind.) IOL = 1.6 mA, VDD = 4.5V (Ind.) IOL = 1.2 mA, VDD = 4.5V (Ext.)

Legend: TBD = To Be Determined.

* These parameters are characterized but not tested.

† Data in 'Typ' column is at 5.0V, 25°C unless otherwise stated. These parameters are for design guidance only and are not tested.

Note 1: In RC oscillator configuration, the OSC1/CLKIN pin is a Schmitt Trigger input. It is not recommended to use an external clock in RC mode.

2: Negative current is defined as current sourced by the pin.

3: The leakage current on the MCLR pin is strongly dependent on the applied voltage level. The specified levels represent normal operating conditions. Higher leakage current may be measured at different input voltages.

4: See Section 10.4.1 "Using the Data EEPROM" for additional information.

15.4 DC Characteristics: PIC16F684 -I (Industrial) PIC16F684 -E (Extended) (Continued)

DC CHARACTERISTICS			Standard Operating Conditions (unless otherwise stated) Operating temperature -40°C ≤ TA ≤ +85°C for industrial -40°C ≤ TA ≤ +125°C for extended				
Param No.	Sym	Characteristic	Min	Typ†	Max	Units	Conditions
D090 D092	VOH	Output High Voltage I/O ports OSC2/CLKOUT (RC mode)	VDD - 0.7 VDD - 0.7	— —	— —	V V	IOH = -3.0 mA, VDD = 4.5V (Ind.) IOH = -1.3 mA, VDD = 4.5V (Ind.) IOH = -1.0 mA, VDD = 4.5V (Ext.)
D100	IULP	Ultra Low-Power Wake-up Current	—	200	—	nA	
D100 D101	COSC2 CIO	Capacitive Loading Specs on Output Pins OSC2 pin All I/O pins	— —	— —	15* 50*	pF pF	In XT, HS and LP modes when external clock is used to drive OSC1
D120 D120A D121 D122 D123 D124	ED ED VDRW TDEW TRET TREF	Data EEPROM Memory Byte Endurance Byte Endurance VDD for Read/Write Erase/Write Cycle Time Characteristic Retention Number of Total Erase/Write Cycles before Refresh ⁽⁴⁾	100K 10K VMIN — 40 1M	1M 100K — 5 — 10M	— — 5.5 6 — —	E/W E/W V ms Year E/W	-40°C ≤ TA ≤ +85°C +85°C ≤ TA ≤ +125°C Using EECON1 to read/write VMIN = Minimum operating voltage Provided no other specifications are violated -40°C ≤ TA ≤ +85°C
D130 D130A D131 D132 D133 D134	EP ED VPR VPEW TPEW TRET	Program Flash Memory Cell Endurance Cell Endurance VDD for Read VDD for Erase/Write Erase/Write cycle time Characteristic Retention	10K 1K VMIN 4.5 — 40	100K 10K — — 2 —	— — 5.5 5.5 2.5 —	E/W E/W V V ms Year	-40°C ≤ TA ≤ +85°C +85°C ≤ TA ≤ +125°C VMIN = Minimum operating voltage Provided no other specifications are violated

Legend: TBD = To Be Determined.

* These parameters are characterized but not tested.

† Data in 'Typ' column is at 5.0V, 25°C unless otherwise stated. These parameters are for design guidance only and are not tested.

Note 1: In RC oscillator configuration, the OSC1/CLKIN pin is a Schmitt Trigger input. It is not recommended to use an external clock in RC mode.

2: Negative current is defined as current sourced by the pin.

3: The leakage current on the MCLR pin is strongly dependent on the applied voltage level. The specified levels represent normal operating conditions. Higher leakage current may be measured at different input voltages.

4: See Section 10.4.1 "Using the Data EEPROM" for additional information.

PIC16F684

15.5 Timing Parameter Symbology

The timing parameter symbols have been created with one of the following formats:

1. TppS2ppS
2. TppS

T		
F	Frequency	T
		Time

Lowercase letters (pp) and their meanings:

pp		
cc	CCP1	osc
ck	CLKOUT	rd
cs	\overline{CS}	rw
di	SDI	sc
do	SDO	ss
dt	Data in	t0
io	I/O port	t1
mc	\overline{MCLR}	wr
		OSC1
		\overline{RD}
		\overline{RD} or \overline{WR}
		SCK
		\overline{SS}
		T0CKI
		T1CKI
		\overline{WR}

Uppercase letters and their meanings:

S		
F	Fall	P
H	High	R
I	Invalid (High-impedance)	V
L	Low	Z
		Period
		Rise
		Valid
		High-impedance

FIGURE 15-2: LOAD CONDITIONS

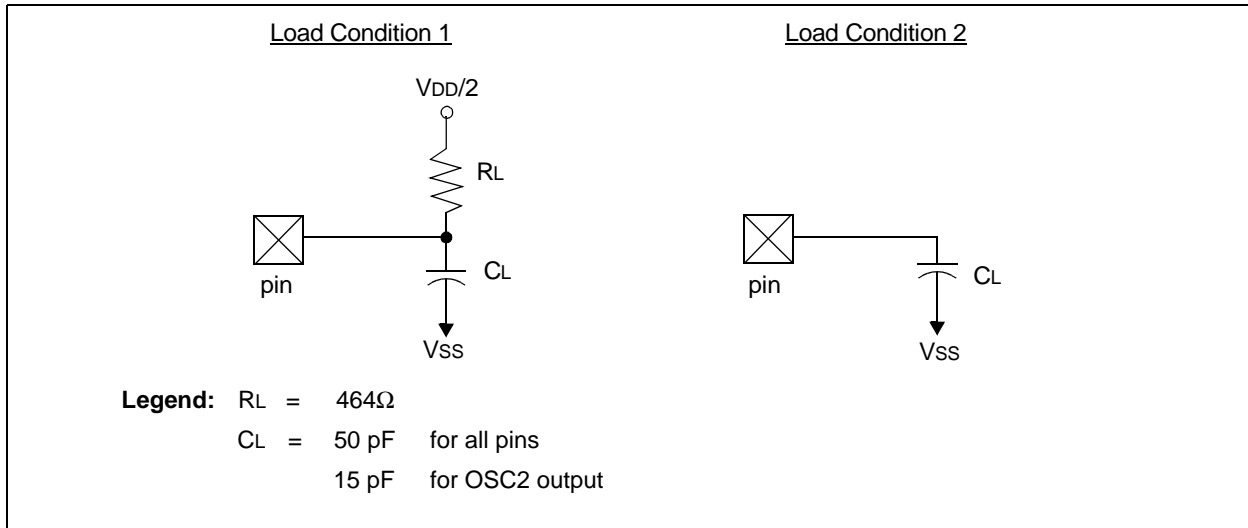

15.6 AC Characteristics: PIC16F684 (Industrial, Extended)

FIGURE 15-3: EXTERNAL CLOCK TIMING

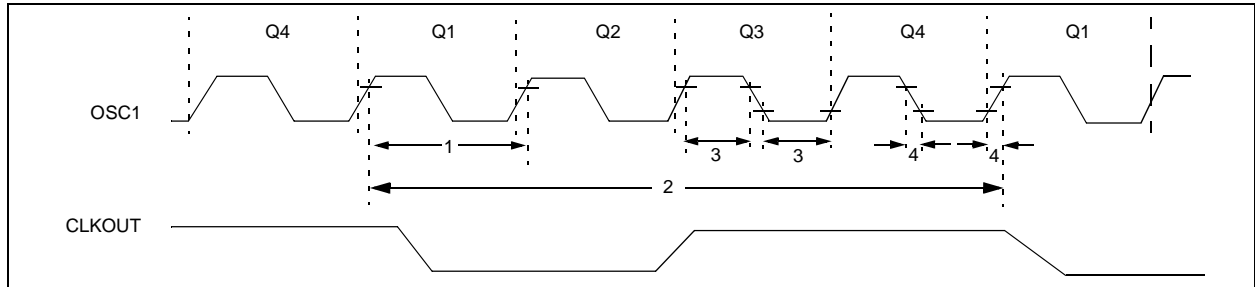

TABLE 15-1: EXTERNAL CLOCK TIMING REQUIREMENTS

Standard Operating Conditions (unless otherwise stated)							
Operating Temperature $-40^{\circ}\text{C} \leq T_A \leq +125^{\circ}\text{C}$							
Param No.	Sym	Characteristic	Min	Typ†	Max	Units	Conditions
	Fosc	External CLKIN Frequency ⁽¹⁾	DC	—	37	kHz	LP Oscillator mode
			DC	—	4	MHz	XT Oscillator mode
			DC	—	20	MHz	HS Oscillator mode
			DC	—	20	MHz	EC Oscillator mode
		Oscillator Frequency ⁽¹⁾	5	—	37	kHz	LP Oscillator mode
			—	4	—	MHz	INTOSC mode
			DC	—	4	MHz	RC Oscillator mode
			0.1	—	4	MHz	XT Oscillator mode
1	Tosc	External CLKIN Period ⁽¹⁾	27	—	∞	μs	LP Oscillator mode
			50	—	∞	ns	HS Oscillator mode
			50	—	∞	ns	EC Oscillator mode
			250	—	∞	ns	XT Oscillator mode
		Oscillator Period ⁽¹⁾	27	—	200	μs	LP Oscillator mode
			—	250	—	ns	INTOSC mode
			250	—	—	ns	RC Oscillator mode
			250	—	10,000	ns	XT Oscillator mode
			50	—	1,000	ns	HS Oscillator mode
2	Tcy	Instruction Cycle Time ⁽¹⁾	200	Tcy	DC	ns	$T_{CY} = 4/F_{osc}$
3	TosL, TosH	External CLKIN (OSC1) High External CLKIN Low	2*	—	—	μs	LP oscillator, TOSC L/H duty cycle
			20*	—	—	ns	HS oscillator, TOSC L/H duty cycle
			100*	—	—	ns	XT oscillator, TOSC L/H duty cycle
4	TosR, TosF	External CLKIN Rise External CLKIN Fall	—	—	50*	ns	LP oscillator
			—	—	25*	ns	XT oscillator
			—	—	15*	ns	HS oscillator

* These parameters are characterized but not tested.

† Data in 'Typ' column is at 5V, 25°C unless otherwise stated. These parameters are for design guidance only and are not tested.

Note 1: Instruction cycle period (Tcy) equals four times the input oscillator time base period. All specified values are based on characterization data for that particular oscillator type under standard operating conditions with the device executing code. Exceeding these specified limits may result in an unstable oscillator operation and/or higher than expected current consumption. All devices are tested to operate at 'min' values with an external clock applied to OSC1 pin. When an external clock input is used, the 'max' cycle time limit is 'DC' (no clock) for all devices.

PIC16F684

TABLE 15-2: PRECISION INTERNAL OSCILLATOR PARAMETERS

Standard Operating Conditions (unless otherwise stated)								
Operating Temperature $-40^{\circ}\text{C} \leq T_A \leq +125^{\circ}\text{C}$								
Param No.	Sym	Characteristic	Freq Tolerance	Min	Typ†	Max	Units	Conditions
F10	FOSC	Internal Calibrated INTOSC Frequency ⁽¹⁾	$\pm 1\%$	—	8.00	TBD	MHz	VDD and Temperature TBD
			$\pm 2\%$	—	8.00	TBD	MHz	$2.5\text{V} \leq V_{DD} \leq 5.5\text{V}$ $0^{\circ}\text{C} \leq T_A \leq +85^{\circ}\text{C}$
			$\pm 5\%$	—	8.00	TBD	MHz	$2.0\text{V} \leq V_{DD} \leq 5.5\text{V}$ $-40^{\circ}\text{C} \leq T_A \leq +85^{\circ}\text{C}$ (Ind.) $-40^{\circ}\text{C} \leq T_A \leq +125^{\circ}\text{C}$ (Ext.)
F14	T _{IOSC ST}	Oscillator Wake-up from Sleep Start-up Time*	—	—	TBD	TBD	μs	$V_{DD} = 2.0\text{V}$, -40°C to $+85^{\circ}\text{C}$
			—	—	TBD	TBD	μs	$V_{DD} = 3.0\text{V}$, -40°C to $+85^{\circ}\text{C}$
			—	—	TBD	TBD	μs	$V_{DD} = 5.0\text{V}$, -40°C to $+85^{\circ}\text{C}$

Legend: TBD = To Be Determined.

* These parameters are characterized but not tested.

† Data in 'Typ' column is at 5.0V, 25°C unless otherwise stated. These parameters are for design guidance only and are not tested.

Note 1: To ensure these oscillator frequency tolerances, VDD and VSS must be capacitively decoupled as close to the device as possible. 0.1 μF and 0.01 μF values in parallel are recommended.

FIGURE 15-4: CLKOUT AND I/O TIMING

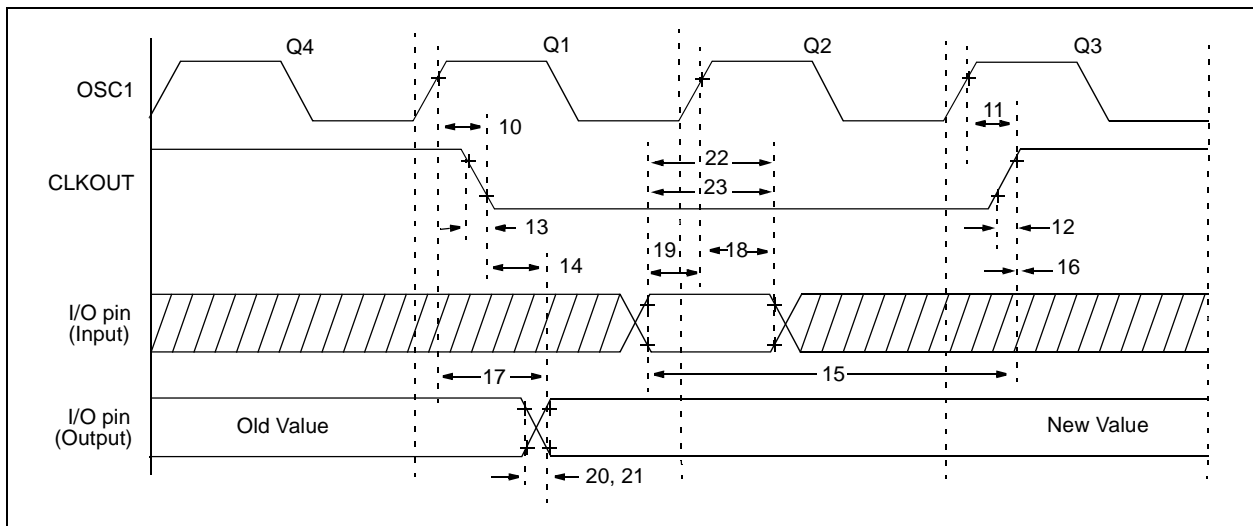

TABLE 15-3: CLKOUT AND I/O TIMING REQUIREMENTS

Standard Operating Conditions (unless otherwise stated)							
Operating Temperature $-40^{\circ}\text{C} \leq T_A \leq +125^{\circ}\text{C}$							
Param No.	Sym	Characteristic	Min	Typ†	Max	Units	Conditions
10	TosH2ckL	OSC1↑ to CLOUT↓	—	75	200	ns	(Note 1)
11	TosH2ckH	OSC1↑ to CLOUT↑	—	75	200	ns	(Note 1)
12	TckR	CLKOUT rise time	—	35	100	ns	(Note 1)
13	TckF	CLKOUT fall time	—	35	100	ns	(Note 1)
14	TckL2ioV	CLKOUT↓ to Port Out Valid	—	—	20	ns	(Note 1)
15	TioV2ckH	Port In Valid before CLKOUT↑	Tosc + 200 ns	—	—	ns	(Note 1)
16	TckH2ioI	Port In Hold after CLKOUT↑	0	—	—	ns	(Note 1)
17	TosH2ioV	OSC1↑ (Q1 cycle) to Port Out Valid	—	50	150*	ns	
			—	—	300	ns	
18	TosH2ioI	OSC1↑ (Q2 cycle) to Port Input Invalid (I/O in hold time)	100	—	—	ns	
19	TioV2osH	Port Input Valid to OSC1↑ (I/O in setup time)	0	—	—	ns	
20	TioR	Port Output Rise Time	—	10	40	ns	
21	TioF	Port Output Fall Time	—	10	40	ns	
22	Tinp	INT Pin High or Low Time	25	—	—	ns	
23	Trbp	PORTA Change INT High or Low Time	Tcy	—	—	ns	

* These parameters are characterized but not tested.

† Data in 'Typ' column is at 5.0V, 25°C unless otherwise stated.

Note 1: Measurements are taken in RC mode where CLKOUT output is 4 x Tosc.

PIC16F684

FIGURE 15-5: RESET, WATCHDOG TIMER, OSCILLATOR START-UP TIMER AND POWER-UP TIMER TIMING

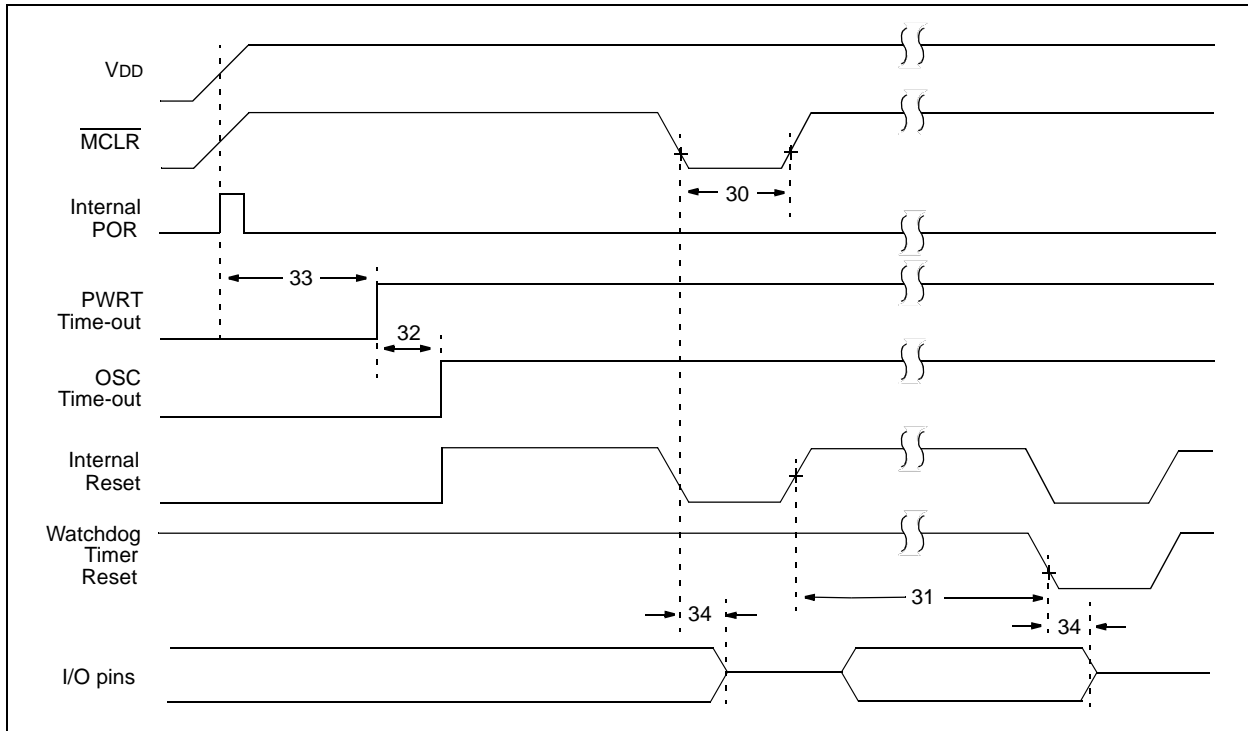

FIGURE 15-6: BROWN-OUT DETECT TIMING AND CHARACTERISTICS

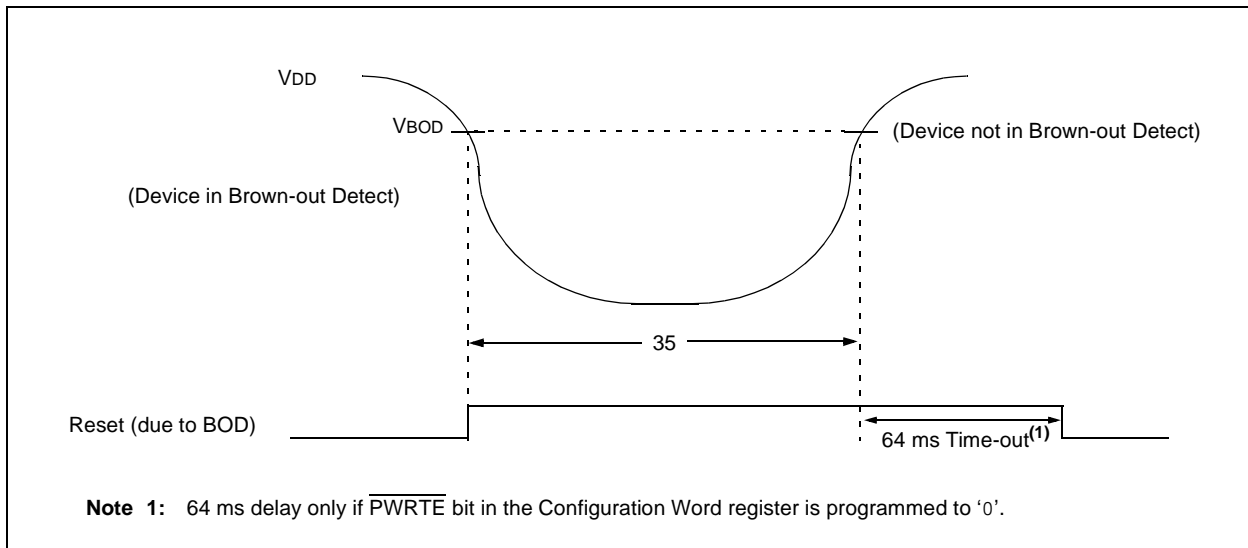

TABLE 15-4: RESET, WATCHDOG TIMER, OSCILLATOR START-UP TIMER, POWER-UP TIMER, AND BROWN-OUT DETECT REQUIREMENTS

Standard Operating Conditions (unless otherwise stated)							
Operating Temperature $-40^{\circ}\text{C} \leq T_A \leq +125^{\circ}\text{C}$							
Param No.	Sym	Characteristic	Min	Typ†	Max	Units	Conditions
30	TMCL	MCLR Pulse Width (low)	2 11	— 18	— 24	μs ms	$V_{DD} = 5\text{V}$, -40°C to $+85^{\circ}\text{C}$ Extended temperature
31	TWDT	Watchdog Timer Time-out Period (No Prescaler)	10 10	17 17	25 30	ms ms	$V_{DD} = 5\text{V}$, -40°C to $+85^{\circ}\text{C}$ Extended temperature
32	TOST	Oscillation Start-up Timer Period	—	$1024T_{\text{osc}}$	—	—	$T_{\text{osc}} = \text{OSC1 period}$
33*	TPWRT	Power-up Timer Period	28* TBD	64 TBD	132* TBD	ms ms	$V_{DD} = 5\text{V}$, -40°C to $+85^{\circ}\text{C}$ Extended Temperature
34	TIOZ	I/O High-impedance from MCLR Low or Watchdog Timer Reset	—	—	2.0	μs	
	VBOD	Brown-out Detect Voltage	2.025	—	2.175	V	
35	TBOD	Brown-out Detect Pulse Width	100*	—	—	μs	$V_{DD} \leq V_{BOD}$ (D005)

Legend: TBD = To Be Determined.

* These parameters are characterized but not tested.

† Data in 'Typ' column is at 5V, 25°C unless otherwise stated. These parameters are for design guidance only and are not tested.

PIC16F684

FIGURE 15-7: TIMER0 AND TIMER1 EXTERNAL CLOCK TIMINGS

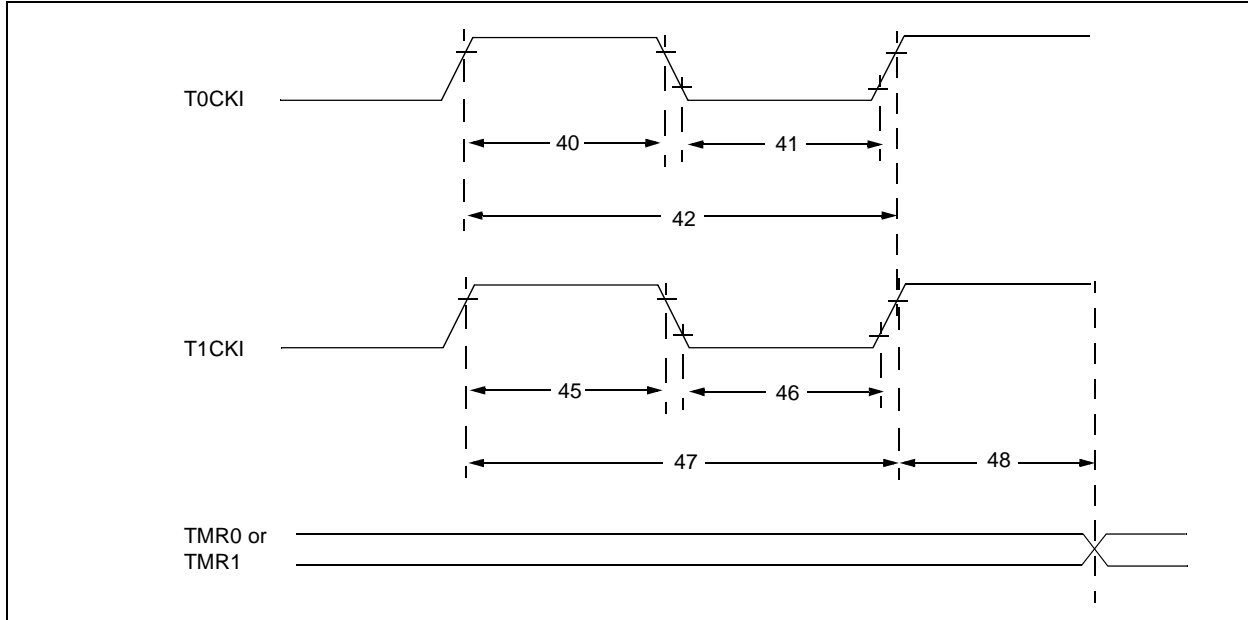

TABLE 15-5: TIMER0 AND TIMER1 EXTERNAL CLOCK REQUIREMENTS

Standard Operating Conditions (unless otherwise stated)								
Operating Temperature $-40^{\circ}\text{C} \leq T_A \leq +125^{\circ}\text{C}$								
Param No.	Sym	Characteristic		Min	Typ†	Max	Units	Conditions
40*	Tt0H	T0CKI High Pulse Width	No Prescaler	$0.5 T_{CY} + 20$	—	—	ns	
			With Prescaler	10	—	—	ns	
41*	Tt0L	T0CKI Low Pulse Width	No Prescaler	$0.5 T_{CY} + 20$	—	—	ns	
			With Prescaler	10	—	—	ns	
42*	Tt0P	T0CKI Period		Greater of: 20 or $\frac{T_{CY} + 40}{N}$	—	—	ns	N = prescale value (2, 4, ..., 256)
45*	Tt1H	T1CKI High Time	Synchronous, No Prescaler	$0.5 T_{CY} + 20$	—	—	ns	
			Synchronous, with Prescaler	15	—	—	ns	
			Asynchronous	30	—	—	ns	
46*	Tt1L	T1CKI Low Time	Synchronous, No Prescaler	$0.5 T_{CY} + 20$	—	—	ns	
			Synchronous, with Prescaler	15	—	—	ns	
			Asynchronous	30	—	—	ns	
47*	Tt1P	T1CKI Input Period	Synchronous	Greater of: 30 or $\frac{T_{CY} + 40}{N}$	—	—	ns	N = prescale value (1, 2, 4, 8)
			Asynchronous	60	—	—	ns	
	Ft1	Timer1 Oscillator Input Frequency Range (oscillator enabled by setting bit T1OSCEN)		DC	—	200*	kHz	
48	TCKEZtmr1	Delay from External Clock Edge to Timer Increment		$2 T_{osc}^*$	—	$7 T_{osc}^*$	—	

* These parameters are characterized but not tested.

† Data in 'Typ' column is at 5V, 25°C unless otherwise stated. These parameters are for design guidance only and are not tested.

FIGURE 15-8: CAPTURE/COMPARE/PWM TIMINGS (ECCP)

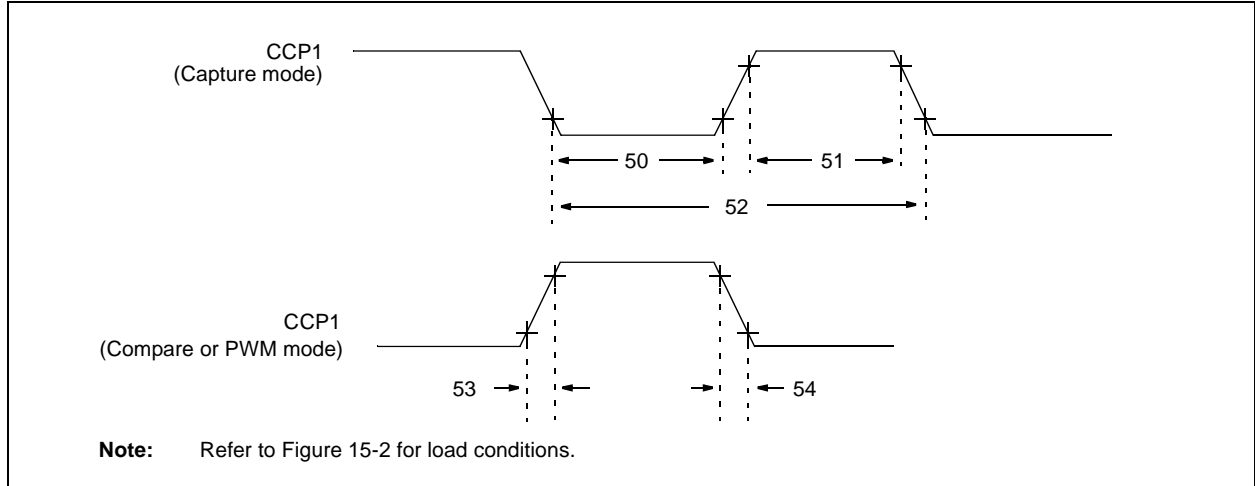

TABLE 15-6: CAPTURE/COMPARE/PWM REQUIREMENTS (ECCP)

Standard Operating Conditions (unless otherwise stated)								
Operating Temperature $-40^{\circ}\text{C} \leq T_A \leq +125^{\circ}\text{C}$								
Param No.	Symbol	Characteristic		Min	Typ†	Max	Units	Conditions
50*	TccL	CCP1 Input Low Time	No Prescaler	$0.5T_{CY} + 20$	—	—	ns	
			With Prescaler	20	—	—	ns	
51*	TccH	CCP1 Input High Time	No Prescaler	$0.5T_{CY} + 20$	—	—	ns	
			With Prescaler	20	—	—	ns	
52*	TccP	CCP1 Input Period		$\frac{3T_{CY} + 40}{N}$	—	—	ns	N = prescale value (1, 4 or 16)
53*	TccR	CCP1 Output Rise Time		—	25	50	ns	
54*	TccF	CCP1 Output Fall Time		—	25	45	ns	

* These parameters are characterized but not tested.

† Data in 'Typ' column is at 5V, 25°C unless otherwise stated. These parameters are for design guidance only and are not tested.

TABLE 15-7: COMPARATOR SPECIFICATIONS

Comparator Specifications		Standard Operating Conditions (unless otherwise stated)				
		Operating temperature $-40^{\circ}\text{C} \leq T_A \leq +125^{\circ}\text{C}$				
Sym	Characteristics	Min	Typ	Max	Units	Comments
Vos	Input Offset Voltage	—	± 5.0	± 10	mV	
VCM	Input Common Mode Voltage	0	—	$V_{DD} - 1.5$	V	
CMRR	Common Mode Rejection Ratio	+55*	—	—	db	
TRT	Response Time ⁽¹⁾	—	150	400*	ns	
TMC2COV	Comparator Mode Change to Output Valid	—	—	10*	μs	

* These parameters are characterized but not tested.

Note 1: Response time measured with one comparator input at $(V_{DD} - 1.5)/2$ while the other input transitions from VSS to $V_{DD} - 1.5V$.

PIC16F684

TABLE 15-8: COMPARATOR VOLTAGE REFERENCE SPECIFICATIONS

Voltage Reference Specifications		Standard Operating Conditions (unless otherwise stated) Operating temperature $-40^{\circ}\text{C} \leq T_A \leq +125^{\circ}\text{C}$				
Sym.	Characteristics	Min	Typ	Max	Units	Comments
	Resolution	—	$V_{DD}/24^*$ $V_{DD}/32$	—	LSb LSb	Low Range (VRR = 1) High Range (VRR = 0)
	Absolute Accuracy	—	—	$\pm 1/4^*$ $\pm 1/2^*$	LSb LSb	Low Range (VRR = 1) High Range (VRR = 0)
	Unit Resistor Value (R)	—	2K*	—	Ω	
	Settling Time ⁽¹⁾	—	—	10*	μs	

* These parameters are characterized but not tested.

Note 1: Settling time measured while VRR = 1 and VR<3:0> transitions from '0000' to '1111'.

TABLE 15-9: PIC16F684 A/D CONVERTER CHARACTERISTICS:

Standard Operating Conditions (unless otherwise stated) Operating temperature $-40^{\circ}\text{C} \leq T_A \leq +125^{\circ}\text{C}$							
Param No.	Sym	Characteristic	Min	Typ†	Max	Units	Conditions
A01	NR	Resolution	—	—	10 bits	bit	
A02	EABS	Total Absolute Error ⁽¹⁾	—	—	± 1	LSb	$V_{REF} = 5.0\text{V}$
A03	EIL	Integral Error	—	—	± 1	LSb	$V_{REF} = 5.0\text{V}$
A04	EDL	Differential Error	—	—	± 1	LSb	No missing codes to 10 bits $V_{REF} = 5.0\text{V}$
A05	EFS	Full-scale Range	2.2*	—	5.5*	V	
A06	E0FF	Offset Error	—	—	± 1	LSb	$V_{REF} = 5.0\text{V}$
A07	EGN	Gain Error	—	—	± 1	LSb	$V_{REF} = 5.0\text{V}$
A10	—	Monotonicity	—	guaranteed ⁽²⁾	—	—	$V_{SS} \leq V_{AIN} \leq V_{REF+}$
A20 A20A	VREF	Reference Voltage	2.2 2.5	—	— $V_{DD} + 0.3$	V	Absolute minimum to ensure 10-bit accuracy
A25	VAIN	Analog Input Voltage	V_{SS}	—	V_{REF}	V	
A30	ZAIN	Recommended Impedance of Analog Voltage Source	—	—	10	k Ω	
A50	IREF	VREF Input Current ⁽³⁾	10	—	1000	μA	During VAIN acquisition. Based on differential of V _{HOLD} to VAIN.
			—	—	10	μA	During A/D conversion cycle.

* These parameters are characterized but not tested.

† Data in 'Typ' column is at 5.0V, 25°C unless otherwise stated. These parameters are for design guidance only and are not tested.

Note 1: Total Absolute Error includes integral, differential, offset and gain errors.

2: The A/D conversion result never decreases with an increase in the input voltage and has no missing codes.

3: VREF current is from external VREF or VDD pin, whichever is selected as reference input.

4: When A/D is off, it will not consume any current other than leakage current. The power-down current specification includes any such leakage from the A/D module.

FIGURE 15-9: PIC16F684 A/D CONVERSION TIMING (NORMAL MODE)

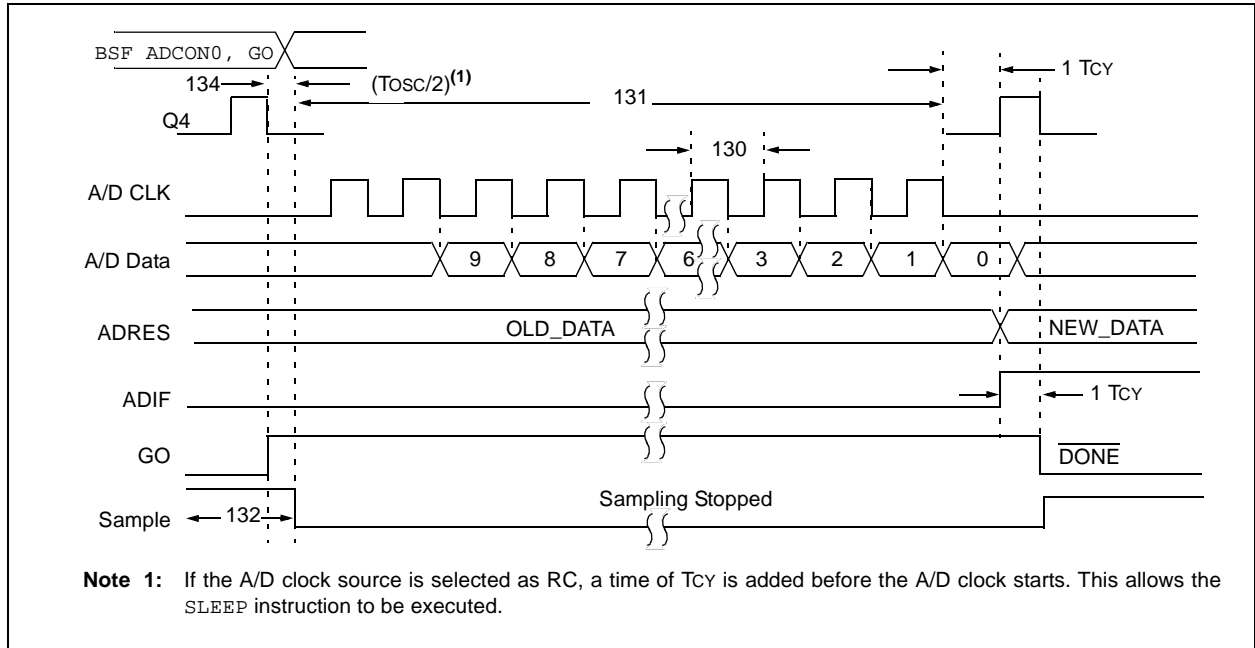

TABLE 15-10: PIC16F684 A/D CONVERSION REQUIREMENTS

Standard Operating Conditions (unless otherwise stated)							
Operating temperature $-40^{\circ}\text{C} \leq T_A \leq +125^{\circ}\text{C}$							
Param No.	Sym	Characteristic	Min	Typ†	Max	Units	Conditions
130	T_{AD}	A/D Clock Period	1.6	—	—	μs	TOSC-based, $V_{REF} \geq 3.0\text{V}$
			3.0*	—	—	μs	TOSC-based, V_{REF} full range
130	T_{AD}	A/D Internal RC Oscillator Period	3.0*	6.0	9.0*	μs	$ADCS\langle 1:0 \rangle = 11$ (RC mode) At $V_{DD} = 2.5\text{V}$
			2.0*	4.0	6.0*	μs	At $V_{DD} = 5.0\text{V}$
131	T_{CNV}	Conversion Time (not including Acquisition Time) ⁽¹⁾	—	11	—	T_{AD}	Set GO bit to new data in A/D Result register
132	T_{ACQ}	Acquisition Time	5*	11.5	—	μs	The minimum time is the amplifier settling time. This may be used if the "new" input voltage has not changed by more than 1 LSb (i.e., 4.1 mV @ 4.096V) from the last sampled voltage (as stored on CHOLD).
			—	—	—	μs	
134	T_{GO}	Q4 to A/D Clock Start	—	$T_{OSC}/2$	—	—	If the A/D clock source is selected as RC, a time of T_{CY} is added before the A/D clock starts. This allows the SLEEP instruction to be executed.

* These parameters are characterized but not tested.

† Data in 'Typ' column is at 5.0V, 25°C unless otherwise stated. These parameters are for design guidance only and are not tested.

Note 1: ADRESH and ADRESL registers may be read on the following T_{CY} cycle.

2: See Table 9-1 for minimum conditions.

PIC16F684

FIGURE 15-10: PIC16F684 A/D CONVERSION TIMING (SLEEP MODE)

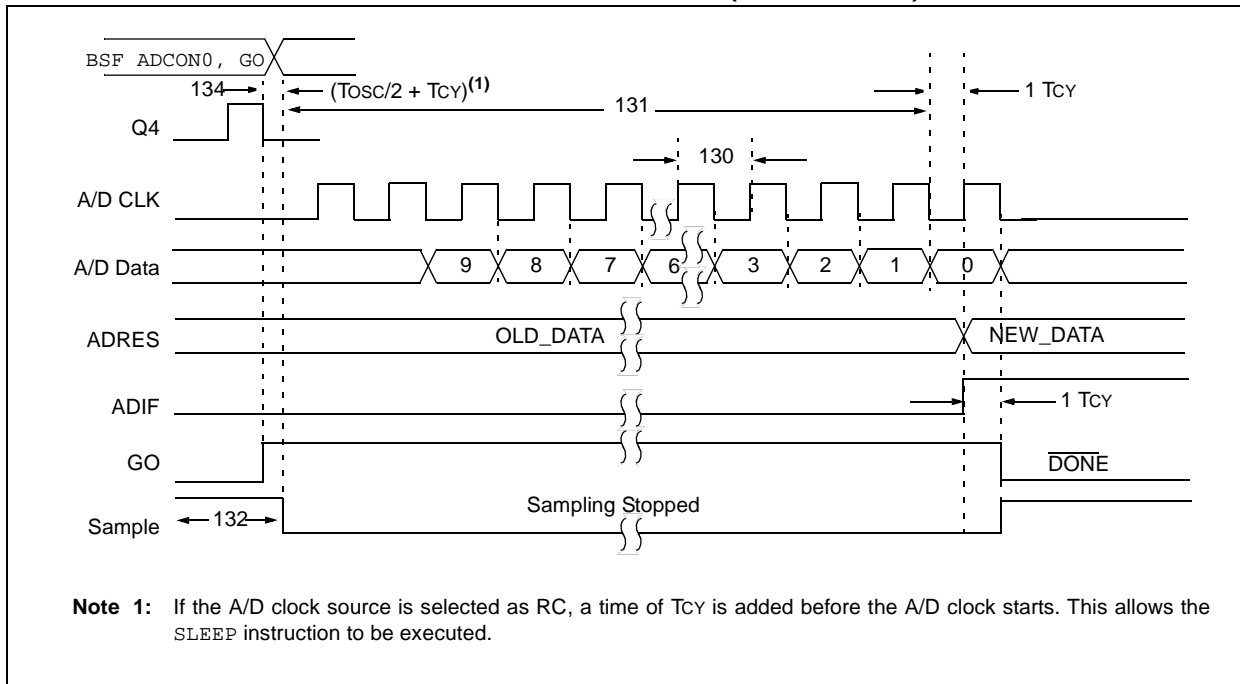

TABLE 15-11: PIC16F684 A/D CONVERSION REQUIREMENTS (SLEEP MODE)

Standard Operating Conditions (unless otherwise stated)							
Operating temperature $-40^{\circ}\text{C} \leq T_A \leq +125^{\circ}\text{C}$							
Param No.	Sym	Characteristic	Min	Typ†	Max	Units	Conditions
130	TAD	A/D Internal RC Oscillator Period	3.0*	6.0	9.0*	μs	ADCS<1:0> = 11 (RC mode) At $V_{DD} = 2.5\text{V}$
			2.0*	4.0	6.0*	μs	At $V_{DD} = 5.0\text{V}$
131	TCNV	Conversion Time (not including Acquisition Time) ⁽¹⁾	—	11	—	TAD	
132	TACQ	Acquisition Time	(2)	11.5	—	μs	The minimum time is the amplifier settling time. This may be used if the “new” input voltage has not changed by more than 1 LSB (i.e., 4.1 mV @ 4.096V) from the last sampled voltage (as stored on CHOLD).
			5*	—	—	μs	
134	TGO	Q4 to A/D Clock Start	—	$T_{OSC}/2 + T_{CY}$	—	—	If the A/D clock source is selected as RC, a time of T_{CY} is added before the A/D clock starts. This allows the <code>SLEEP</code> instruction to be executed.

* These parameters are characterized but not tested.

† Data in ‘Typ’ column is at 5.0V, 25°C unless otherwise stated. These parameters are for design guidance only and are not tested.

Note 1: ADRES register may be read on the following T_{CY} cycle.

2: See Table 9-1 for minimum conditions.

16.0 DC AND AC CHARACTERISTICS GRAPHS AND TABLES

Graphs are not available at this time.

PIC16F684

NOTES:

17.0 PACKAGING INFORMATION

17.1 Package Marking Information

14-Lead PDIP (Skinny DIP)

XXXXXXXXXXXXXXXXXX
XXXXXXXXXXXXXXXXXX
○  YYWWNNN

Example

16F684-I
○  0415017

14-Lead SOIC

XXXXXXXXXXXX
XXXXXXXXXXXX
○  YYWWNNN

Example

16F684-E
○  0415017

14-Lead TSSOP

XXXXXXXX
 YYWW
○ NNN

Example

16F684
 0415
○ 017

Legend:	XX...X	Customer specific information*
	Y	Year code (last digit of calendar year)
	YY	Year code (last 2 digits of calendar year)
	WW	Week code (week of January 1 is week '01')
	NNN	Alphanumeric traceability code
Note: In the event the full Microchip part number cannot be marked on one line, it will be carried over to the next line thus limiting the number of available characters for customer specific information.		

* Standard PICmicro device marking consists of Microchip part number, year code, week code, and traceability code. For PICmicro device marking beyond this, certain price adders apply. Please check with your Microchip Sales Office. For QTP devices, any special marking adders are included in QTP price.

PIC16F684

17.2 Package Details

The following sections give the technical details of the packages.

14-Lead Plastic Dual In-line (P) – 300 mil (PDIP)

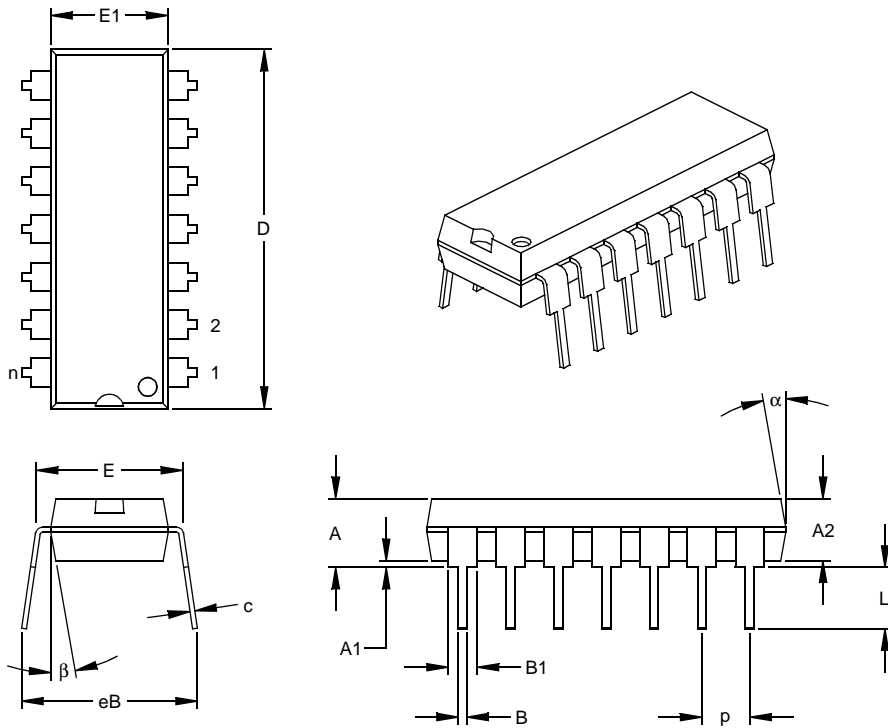

Units		INCHES*			MILLIMETERS		
Dimension Limits		MIN	NOM	MAX	MIN	NOM	MAX
Number of Pins	n		14			14	
Pitch	p		.100			2.54	
Top to Seating Plane	A	.140	.155	.170	3.56	3.94	4.32
Molded Package Thickness	A2	.115	.130	.145	2.92	3.30	3.68
Base to Seating Plane	A1	.015			0.38		
Shoulder to Shoulder Width	E	.300	.313	.325	7.62	7.94	8.26
Molded Package Width	E1	.240	.250	.260	6.10	6.35	6.60
Overall Length	D	.740	.750	.760	18.80	19.05	19.30
Tip to Seating Plane	L	.125	.130	.135	3.18	3.30	3.43
Lead Thickness	c	.008	.012	.015	0.20	0.29	0.38
Upper Lead Width	B1	.045	.058	.070	1.14	1.46	1.78
Lower Lead Width	B	.014	.018	.022	0.36	0.46	0.56
Overall Row Spacing	§ eB	.310	.370	.430	7.87	9.40	10.92
Mold Draft Angle Top	α	5	10	15	5	10	15
Mold Draft Angle Bottom	β	5	10	15	5	10	15

* Controlling Parameter

§ Significant Characteristic

Notes:

Dimensions D and E1 do not include mold flash or protrusions. Mold flash or protrusions shall not exceed

.010" (0.254mm) per side.

JEDEC Equivalent: MS-001

Drawing No. C04-005

14-Lead Plastic Small Outline (SL) – Narrow, 150 mil (SOIC)

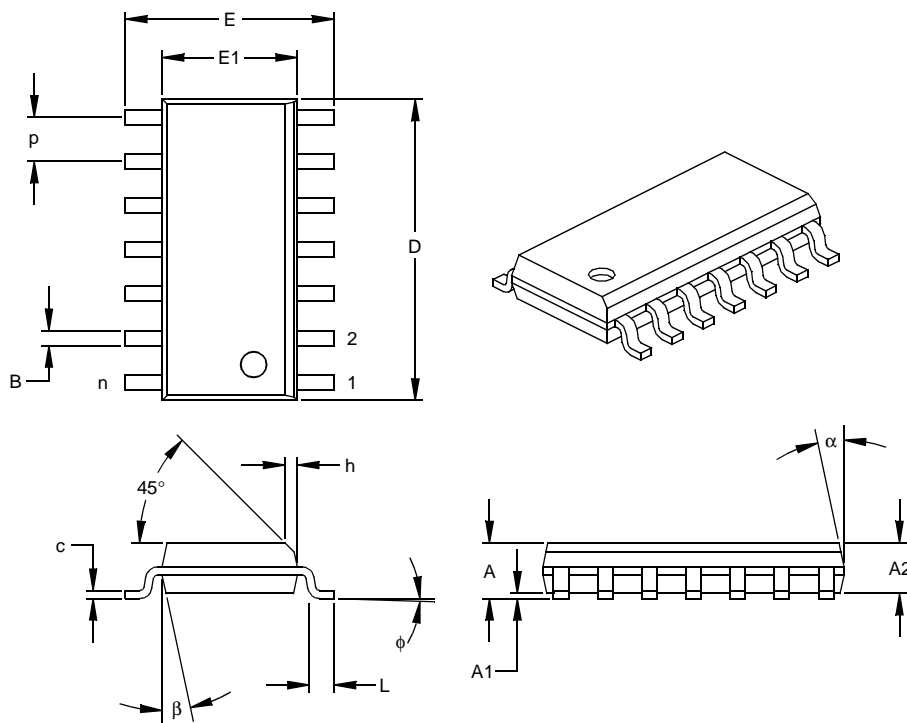

Units		INCHES*			MILLIMETERS		
Dimension Limits		MIN	NOM	MAX	MIN	NOM	MAX
Number of Pins	n		14			14	
Pitch	p		.050			1.27	
Overall Height	A	.053	.061	.069	1.35	1.55	1.75
Molded Package Thickness	A2	.052	.056	.061	1.32	1.42	1.55
Standoff §	A1	.004	.007	.010	0.10	0.18	0.25
Overall Width	E	.228	.236	.244	5.79	5.99	6.20
Molded Package Width	E1	.150	.154	.157	3.81	3.90	3.99
Overall Length	D	.337	.342	.347	8.56	8.69	8.81
Chamfer Distance	h	.010	.015	.020	0.25	0.38	0.51
Foot Length	L	.016	.033	.050	0.41	0.84	1.27
Foot Angle	φ	0	4	8	0	4	8
Lead Thickness	c	.008	.009	.010	0.20	0.23	0.25
Lead Width	B	.014	.017	.020	0.36	0.42	0.51
Mold Draft Angle Top	α	0	12	15	0	12	15
Mold Draft Angle Bottom	β	0	12	15	0	12	15

* Controlling Parameter

§ Significant Characteristic

Notes:

Dimensions D and E1 do not include mold flash or protrusions. Mold flash or protrusions shall not exceed .010" (0.254mm) per side.

JEDEC Equivalent: MS-012

Drawing No. C04-065

PIC16F684

14-Lead Plastic Thin Shrink Small Outline (ST) – 4.4 mm (TSSOP)

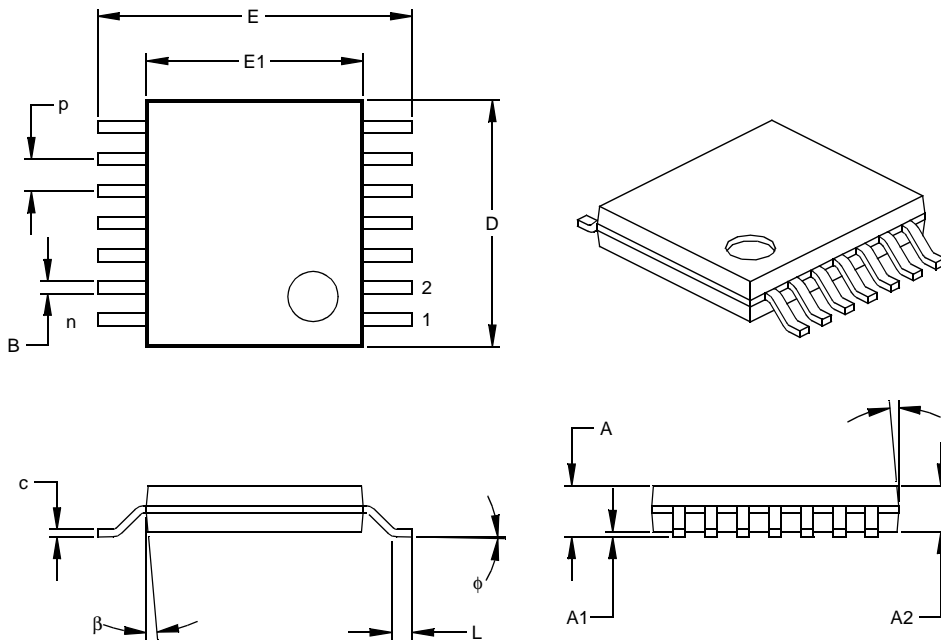

Dimension Limits	Units	INCHES			MILLIMETERS*		
		MIN	NOM	MAX	MIN	NOM	MAX
Number of Pins	n		14			14	
Pitch	p		.026			0.65	
Overall Height	A			.043			1.10
Molded Package Thickness	A2	.033	.035	.037	0.85	0.90	0.95
Standoff §	A1	.002	.004	.006	0.05	0.10	0.15
Overall Width	E	.246	.251	.256	6.25	6.38	6.50
Molded Package Width	E1	.169	.173	.177	4.30	4.40	4.50
Molded Package Length	D	.193	.197	.201	4.90	5.00	5.10
Foot Length	L	.020	.024	.028	0.50	0.60	0.70
Foot Angle	φ	0	4	8	0	4	8
Lead Thickness	c	.004	.006	.008	0.09	0.15	0.20
Lead Width	B	.007	.010	.012	0.19	0.25	0.30
Mold Draft Angle Top	α	0	5	10	0	5	10
Mold Draft Angle Bottom	β	0	5	10	0	5	10

* Controlling Parameter
 § Significant Characteristic

Notes:

Dimensions D and E1 do not include mold flash or protrusions. Mold flash or protrusions shall not exceed .005" (0.127mm) per side.

JEDEC Equivalent: MO-153

Drawing No. C04-087

APPENDIX A: DATA SHEET REVISION HISTORY

Revision A

This is a new data sheet.

Revision B

Rewrites of the Oscillator and Special Features of the CPU Sections. General corrections to Figures and formatting.

APPENDIX B: MIGRATING FROM OTHER PICmicro® DEVICES

This discusses some of the issues in migrating from other PICmicro devices to the PIC16F6XX Family of devices.

B.1 PIC16F676 to PIC16F684

TABLE B-1: FEATURE COMPARISON

Feature	PIC16F676	PIC16F684
Max Operating Speed	20 MHz	20 MHz
Max Program Memory (Words)	1024	2048
SRAM (bytes)	64	128
A/D Resolution	10-bit	10-bit
Data EEPROM (Bytes)	128	256
Timers (8/16-bit)	1/1	2/1
Oscillator Modes	8	8
Brown-out Detect	Y	Y
Internal Pull-ups	RA0/1/2/4/5	RA0/1/2/4/5, MCLR
Interrupt-on-change	RA0/1/2/3/4/5	RA0/1/2/3/4/5
Comparator	1	2
ECCP	N	Y
Ultra Low-Power Wake-up	N	Y
Extended WDT	N	Y
Software Control Option of WDT/BOD	N	Y
INTOSC Frequencies	4 MHz	32 kHz- 8 MHz
Clock Switching	N	Y

Note: This device has been designed to perform to the parameters of its data sheet. It has been tested to an electrical specification designed to determine its conformance with these parameters. Due to process differences in the manufacture of this device, this device may have different performance characteristics than its earlier version. These differences may cause this device to perform differently in your application than the earlier version of this device.

PIC16F684

NOTES:

INDEX

A

A/D	63
Acquisition Requirements	68
Analog Port Pins	63
Associated Registers	70
Block Diagram	63
Calculating Acquisition Time	68
Channel Selection	63
Configuration and Operation	63
Configuring	67
Configuring Interrupt	67
Conversion Clock	64
Effects of a Reset	69
Internal Sampling Switch (Rss) Impedance	68
Operation During Sleep	69
Output Format	65
Reference Voltage (VREF)	63
Source Impedance	68
Special Event Trigger	69
Specifications	144, 145, 146
Starting a Conversion	64
Using the ECCP Trigger	69
Absolute Maximum Ratings	127
AC Characteristics	
Industrial and Extended	137
Load Conditions	136
ADCON0 Register	66
ADCON1 Register	66
Analog Front-end (AFE)	
Power-On Reset	95
Analog Input Connection Considerations	56
Analog-to-Digital Converter. <i>See</i> A/D	
ANSEL Register	65
Assembler	
MPASM Assembler	121

B

Block Diagrams	
A/D	63
Analog Input Model	56, 68
Capture Mode Operation	76
Comparator 1	58
Comparator 2	58
Comparator Modes	57
Comparator Voltage Reference (CVREF)	60
Compare	77
Fail-Safe Clock Monitor (FSCM)	27
In-Circuit Serial Programming Connections	109
Interrupt Logic	102
MCLR Circuit	95
On-Chip Reset Circuit	94
PIC16F684	5
PWM (Enhanced)	78
RA0 Pins	35
RA1 Pins	36
RA2 Pin	37
RA3 Pin	37
RA4 Pin	38
RA5 Pin	38
RC0 and RC1 Pins	40
RC2 and RC3 Pins	41
RC4 Pin	41
RC5 Pin	42
Resonator Operation	21

System Clock	19
Timer1	49
Timer2	54
TMR0/WDT Prescaler	45
Watchdog Timer (WDT)	105
Brown-out Detect (BOD)	96
Associated	97
Calibration	96
Specifications	141
Timing and Characteristics	140

C

C Compilers	
MPLAB C17	122
MPLAB C18	122
MPLAB C30	122
CALIB Register	93
Calibration Bits	93
Capture Module. <i>See</i> Enhanced	
Capture/Compare/PWM (ECCP)	
CCP1CON Register	75
CCPR1H Register	75
CCPR1L Register	75
CMCON0 Register	55
CMCON1 Register	59
Code Examples	
Assigning Prescaler to Timer0	47
Assigning Prescaler to WDT	47
Changing Between Capture Prescalers	76
Data EEPROM Read	73
Data EEPROM Write	73
Indirect Addressing	17
Initializing A/D	67
Initializing PORTA	31
Initializing PORTC	40
Saving Status and W Registers in RAM	104
Ultra Low-Power Wake-up Initialization	34
Write Verify	73
Code Protection	108
Comparator Voltage Reference (CVREF)	60
Accuracy/Error	60
Associated registers	62
Configuring	60
Effects of a Reset	61
Response Time	61
Specifications	144
Comparators	55
Associated Registers	62
C2OUT as T1 Gate	50, 59
Configurations	57
Effects of a Reset	61
Interrupts	59
Operation	56
Operation During Sleep	61
Outputs	59
Response Time	61
Specifications	143
Synchronizing C2OUT w/ Timer1	59
Compare Module. <i>See</i> Enhanced	
Capture/Compare/PWM (ECCP)	
CONFIG Register	92
Configuration Bits	92
CPU Features	91

PIC16F684

D		
Data EEPROM Memory		
Associated Registers	74	
Code Protection	71, 74	
Data Memory	7	
DC Characteristics		
Extended and Industrial	134	
Industrial and Extended	129	
Demonstration Boards		
PICDEM 1	124	
PICDEM 17	125	
PICDEM 18R	125	
PICDEM 2 Plus	124	
PICDEM 3	124	
PICDEM 4	124	
PICDEM LIN	125	
PICDEM USB	125	
PICDEM.net Internet/Ethernet	124	
Development Support	121	
Device Overview	5	
E		
ECCP. <i>See</i> Enhanced Capture/Compare/PWM (ECCP)		
ECCPAS Register	86	
EEADR Register	71	
EECON1 Register	72	
EECON2 Register	72	
EEDAT Register	71	
EEPROM Data Memory		
Avoiding Spurious Write	74	
Reading	73	
Write Verify	73	
Writing	73	
Electrical Specifications	127	
Enhanced Capture/Compare/PWM (ECCP)	75	
Associated registers	89	
Associated registers w/ Capture/Compare/Timer1	77	
Capture Mode	76	
Prescaler	76	
CCP1 Pin Configuration	76	
Compare Mode	77	
CCP1 Pin Configuration	77	
Software Interrupt Mode	77	
Special Event Trigger and A/D Conversions	77	
Special Trigger Output	77	
Timer1 Mode Selection	77	
Enhanced PWM Mode	78	
Auto-restart	87	
Auto-shutdown	85, 87	
Direction Change in Full-Bridge Output Mode	83	
Duty Cycle	79	
Effects of Reset	88	
Example PWM Frequencies and Resolutions	79	
Full-Bridge Application Example	83	
Full-Bridge Mode	82	
Half-Bridge Application Examples	81	
Half-Bridge Mode	81	
Operation in Power Managed Modes	88	
Operation with Fail-Safe Clock Monitor	88	
Output Configurations	78	
Output Relationships (Active-High and Active-Low)		
80		
Output Relationships Diagram	80	
Period	79	
Programmable Dead Band Delay	85	
Setup for Operation	88	
Shoot-through Current	85	
Start-up Considerations	87	
TMR2 to PR2 Match	53	
Specifications	143	
Timer Resources	75	
Errata	3	
Evaluation and Programming Tools	125	
F		
Fail-Safe Clock Monitor	27	
Fail-Safe Mode	27	
Reset and Wake-up from Sleep	28	
Firmware Instructions	111	
Fuses. <i>See</i> Configuration Bits		
G		
General Purpose Register File	8	
I		
ID Locations	108	
In-Circuit Debugger	109	
In-Circuit Serial Programming (ICSP)	108	
Indirect Addressing, INDF and FSR registers	17	
Instruction Format	111	
Instruction Set	111	
ADDLW	113	
ADDWF	113	
ANDLW	113	
ANDWF	113	
BCF	113	
BSF	113	
BTFSC	113	
BTFSS	114	
CALL	114	
CLRF	114	
CLRWF	114	
CLRWDT	114	
COMF	114	
DECF	114	
DECFSZ	115	
GOTO	115	
INCF	115	
INCFSZ	115	
IORLW	115	
IORWF	115	
MOVF	116	
MOVLW	116	
MOVWF	116	
NOP	116	
RETFIE	117	
RETLW	117	
RETURN	117	
RLF	118	
RRF	118	
SLEEP	118	
SUBLW	118	
SUBWF	119	
SWAPF	119	
XORLW	119	
XORWF	119	
Summary Table	112	
INTCON Register	13	
Internal Oscillator Block		
INTOSC		
Specifications	138	

Internal Sampling Switch (Rss) Impedance.....	68	PIE1 Register	14
Interrupts.....	101	Pin Diagram	2
A/D.....	67	Pinout Descriptions	
Associated Registers	103	PIC16F684	6
Capture	76	PIR1 Register	15
Comparators	59	PORTA	31
Compare	77	Additional Pin Functions	31
Context Saving.....	104	Interrupt-on-Change	33
Data EEPROM Memory Write	72	Ultra Low-Power Wake-up.....	31, 34
Interrupt-on-Change.....	33	Weak Pull-up	31
PORTA Interrupt-on-Change	102	Associated registers	39
RA2/INT	101	Pin Descriptions and Diagrams	36
TMR0	102	RA0.....	36
TMR1	50	RA1.....	36
TMR2 to PR2 Match	54	RA2.....	37
TMR2 to PR2 Match (PWM)	53	RA3.....	37
INTOSC Specifications	138	RA4.....	38
IOCA Register.....	33	RA5.....	38
		Specifications	139
L		PORTC.....	40
Load Conditions	136	Associated Registers.....	29
		Associated registers	43
M		P1A/P1B/P1C/P1D. See Enhanced	
MCLR	95	Capture/Compare/PWM (ECCP).....	40
Internal.....	95	Specifications	139
Memory Organization.....	7	Power-Down Mode (Sleep).....	107
Data	7	Power-on Reset (POR).....	95
Data EEPROM Memory.....	71	Power-up Timer (PWRT)	96
Program	7	Specifications	141
Migrating from other PICmicro Devices	153	Precision Internal Oscillator Parameters	138
MPLAB ASM30 Assembler, Linker, Librarian	122	Prescaler	
MPLAB ICD 2 In-Circuit Debugger	123	Shared WDT/Timer0.....	47
MPLAB ICE 2000 High-Performance Universal		Switching Prescaler Assignment	47
In-Circuit Emulator	123	PRO MATE II Universal Device Programmer	123
MPLAB ICE 4000 High-Performance Universal		Product Identification	161
In-Circuit Emulator	123	Program Memory.....	7
MPLAB Integrated Development Environment Software ..	121	Map and Stack.....	7
MPLAB PM3 Device Programmer	123	Programming, Device Instructions.....	111
MPLINK Object Linker/MPLIB Object Librarian	122	PWM Mode. See Enhanced Capture/Compare/PWM.....	78
		PWM1CON Register.....	85
O			
OPCODE Field Descriptions.....	111	R	
OPTION_REG Register	12	Read-Modify-Write Operations	111
OSCCON Register.....	29	Registers	
Oscillator		ADCON0 (A/D Control 0).....	66
Associated registers.....	29	ADCON1 (A/D Control 1).....	66
Oscillator Configurations.....	19	ANSEL (Analog Select)	65
Oscillator Specifications	137	CALIB (Calibration Word)	93
Oscillator Start-up Timer (OST)		CCP1CON (Enhanced CCP Operation)	75
Specifications.....	141	CCPR1H.....	75
Oscillator Switching		CCPR1L	75
Fail-Safe Clock Monitor.....	27	CMCON0 (Comparator Control 0)	55
Two-Speed Clock Start-up.....	25	CMCON1 (Comparator Control 1)	59
		CONFIG (Configuration Word)	92
P		Data Memory Map	8
P1A/P1B/P1C/P1D. See Enhanced		ECCPAS (Enhanced CCP Auto-shutdown Control) ..	86
Capture/Compare/PWM (ECCP)	78	EEADR (EEPROM Address).....	71
Packaging	149	EECON1 (EEPROM Control 1)	72
Marking	149	EECON2 (EEPROM Control 2)	72
PDIP Details.....	150	EEDAT (EEPROM Data)	71
PCL and PCLATH.....	17	INTCON (Interrupt Control)	13
Computed GOTO.....	17	IOCA (Interrupt-on-change PORTA)	33
Stack.....	17	OPTION_REG	46
PCON Register	97	OPTION_REG (Option)	12
PICkit 1 Flash Starter Kit.....	125	OSCCON (Oscillator Control).....	29
PICSTART Plus Development Programmer	124	PCON (Power Control)	97

PIC16F684

PIE1 (Peripheral Interrupt Enable 1)	14	CLKOUT and I/O	138
PIR1 (Peripheral Interrupt Register 1)	15	Comparator Output	56
PORTA	31	Enhanced Capture/Compare/PWM (ECCP)	143
PORTC	43	External Clock	137
PWM1CON (Enhanced PWM Configuration)	85	Fail-Safe Clock Monitor (FSCM)	28
Reset Values	99	Full-Bridge PWM Output	82
Reset Values (special registers)	100	Half-Bridge PWM Output	81
Special Function Registers	8	INT Pin Interrupt	103
Special Register Summary	10	PWM Auto-shutdown	
Status	11	Auto-restart Disabled	87
T1CON (Timer1 Control)	51	Auto-restart Enabled	87
T2CON (Timer2 Control)	53	PWM Direction Change	84
TRISA (Tri-state PORTA)	32	PWM Direction Change at Near 100% Duty Cycle	84
TRISC (Tri-state PORTC)	43	PWM Output (Active-High)	80
VRCON (Voltage Reference Control)	62	PWM Output (Active-Low)	80
WDTCON (Watchdog Timer Control)	106	Reset, WDT, OST and Power-up Timer	140
WPUA (Weak Pull-up PORTA)	32	Time-out Sequence	
Reset	94	Case 1	98
Revision History	153	Case 2	98
		Case 3	98
S		Timer0 and Timer1 External Clock	142
Shoot-through Current	85	Timer1 Incrementing Edge	50
Software Simulator (MPLAB SIM)	122	Two Speed Start-up	26
Software Simulator (MPLAB SIM30)	122	Wake-up from Interrupt	108
Special Event Trigger	69	Timing Parameter Symbology	136
Special Function Registers	8	TRISA Register	32
Status Register	11	TRISC Register	43
		Two-Speed Clock Start-up Mode	25
T			
Time-out Sequence	97	U	
Timer0	45	Ultra Low-Power Wake-up	31, 34
Associated Registers	47	Ultra Low-power Wake-up	6
External Clock	46		
Interrupt	45	V	
Operation	45	Voltage Reference. See Comparator	
Specifications	142	Voltage Reference (CVREF)	
T0CKI	46	VRCON Register	62
Timer1	49	VREF. SEE A/D Reference Voltage	
Associated registers	52		
Asynchronous Counter Mode	52	W	
Reading and Writing	52	Wake-up Using Interrupts	107
Interrupt	50	Watchdog Timer (WDT)	105
Modes of Operations	50	Associated registers	106
Operation During Sleep	52	Clock Source	105
Oscillator	52	Modes	105
Prescaler	50	Period	105
Specifications	142	Specifications	141
Timer1 Gate		WDTCON Register	106
Inverting Gate	50	WPUA Register	32
Selecting Source	50, 59	WWW, On-Line Support	3
Synchronizing C2OUT w/ Timer1	59		
TMR1H Register	49		
TMR1L Register	49		
Timer2	53		
Associated Registers	54		
Operation	53		
Postscaler	53		
PR2 Register	53		
Prescaler	53		
TMR2 Register	53		
TMR2 to PR2 Match Interrupt	53, 54		
Timing Diagrams			
A/D Conversion	145		
A/D Conversion (Sleep Mode)	146		
Brown-out Detect (BOD)	140		
Brown-out Detect Situations	96		

ON-LINE SUPPORT

Microchip provides on-line support on the Microchip World Wide Web site.

The web site is used by Microchip as a means to make files and information easily available to customers. To view the site, the user must have access to the Internet and a web browser, such as Netscape® or Microsoft® Internet Explorer. Files are also available for FTP download from our FTP site.

Connecting to the Microchip Internet Web Site

The Microchip web site is available at the following URL:

www.microchip.com

The file transfer site is available by using an FTP service to connect to:

<ftp://ftp.microchip.com>

The web site and file transfer site provide a variety of services. Users may download files for the latest Development Tools, Data Sheets, Application Notes, User's Guides, Articles and Sample Programs. A variety of Microchip specific business information is also available, including listings of Microchip sales offices, distributors and factory representatives. Other data available for consideration is:

- Latest Microchip Press Releases
- Technical Support Section with Frequently Asked Questions
- Design Tips
- Device Errata
- Job Postings
- Microchip Consultant Program Member Listing
- Links to other useful web sites related to Microchip Products
- Conferences for products, Development Systems, technical information and more
- Listing of seminars and events

SYSTEMS INFORMATION AND UPGRADE HOT LINE

The Systems Information and Upgrade Line provides system users a listing of the latest versions of all of Microchip's development systems software products. Plus, this line provides information on how customers can receive the most current upgrade kits. The Hot Line Numbers are:

1-800-755-2345 for U.S. and most of Canada, and

1-480-792-7302 for the rest of the world.

042003

PIC16F684

READER RESPONSE

It is our intention to provide you with the best documentation possible to ensure successful use of your Microchip product. If you wish to provide your comments on organization, clarity, subject matter, and ways in which our documentation can better serve you, please FAX your comments to the Technical Publications Manager at (480) 792-4150.

Please list the following information, and use this outline to provide us with your comments about this document.

To: Technical Publications Manager
RE: Reader Response
From: Name _____
Company _____
Address _____
City / State / ZIP / Country _____
Telephone: (_____) _____ - _____ FAX: (_____) _____ - _____

Application (optional):

Would you like a reply? ___Y ___N

Device: PIC16F684

Literature Number: DS41202C

Questions:

1. What are the best features of this document?

2. How does this document meet your hardware and software development needs?

3. Do you find the organization of this document easy to follow? If not, why?

4. What additions to the document do you think would enhance the structure and subject?

5. What deletions from the document could be made without affecting the overall usefulness?

6. Is there any incorrect or misleading information (what and where)?

7. How would you improve this document?

PRODUCT IDENTIFICATION SYSTEM

To order or obtain information, e.g., on pricing or delivery, refer to the factory or the listed sales office.

<u>PART NO.</u>	<u>X</u>	<u>/XX</u>	<u>XXX</u>
Device	Temperature Range	Package	Pattern
Device	16F: Standard V _{DD} range 16FT: (Tape and Reel)		
Temperature Range	I = -40°C to +85°C E = -40°C to +125°C		
Package	P = PDIP SL = SOIC (Gull wing, 150 mil body) ST = TSSOP(4.4 mm)		
Pattern	3-Digit Pattern Code for QTP (blank otherwise)		

Examples:

a) PIC16F684-E/P 301 = Extended Temp., PDIP package, 20 MHz, QTP pattern #301

b) PIC16F684-I/SO = Industrial Temp., SOIC package, 20 MHz

* JW Devices are UV erasable and can be programmed to any device configuration. JW Devices meet the electrical requirement of each oscillator type.



WORLDWIDE SALES AND SERVICE

AMERICAS

Corporate Office

2355 West Chandler Blvd.
Chandler, AZ 85224-6199
Tel: 480-792-7200
Fax: 480-792-7277
Technical Support: 480-792-7627
Web Address: www.microchip.com

Atlanta

3780 Mansell Road, Suite 130
Alpharetta, GA 30022
Tel: 770-640-0034
Fax: 770-640-0307

Boston

2 Lan Drive, Suite 120
Westford, MA 01886
Tel: 978-692-3848
Fax: 978-692-3821

Chicago

333 Pierce Road, Suite 180
Itasca, IL 60143
Tel: 630-285-0071
Fax: 630-285-0075

Dallas

4570 Westgrove Drive, Suite 160
Addison, TX 75001
Tel: 972-818-7423
Fax: 972-818-2924

Detroit

Tri-Atria Office Building
32255 Northwestern Highway, Suite 190
Farmington Hills, MI 48334
Tel: 248-538-2250
Fax: 248-538-2260

Kokomo

2767 S. Albright Road
Kokomo, IN 46902
Tel: 765-864-8360
Fax: 765-864-8387

Los Angeles

18201 Von Karman, Suite 1090
Irvine, CA 92612
Tel: 949-263-1888
Fax: 949-263-1338

San Jose

1300 Terra Bella Avenue
Mountain View, CA 94043
Tel: 650-215-1444
Fax: 650-961-0286

Toronto

6285 Northam Drive, Suite 108
Mississauga, Ontario L4V 1X5, Canada
Tel: 905-673-0699
Fax: 905-673-6509

ASIA/PACIFIC

Australia

Suite 22, 41 Rawson Street
Epping 2121, NSW
Australia
Tel: 61-2-9868-6733
Fax: 61-2-9868-6755

China - Beijing

Unit 706B
Wan Tai Bei Hai Bldg.
No. 6 Chaoyangmen Bei Str.
Beijing, 100027, China
Tel: 86-10-85282100
Fax: 86-10-85282104

China - Chengdu

Rm. 2401-2402, 24th Floor,
Ming Xing Financial Tower
No. 88 TIDU Street
Chengdu 610016, China
Tel: 86-28-86766200
Fax: 86-28-86766599

China - Fuzhou

Unit 28F, World Trade Plaza
No. 71 Wusi Road
Fuzhou 350001, China
Tel: 86-591-7503506
Fax: 86-591-7503521

China - Hong Kong SAR

Unit 901-6, Tower 2, Metroplaza
223 Hing Fong Road
Kwai Fong, N.T., Hong Kong
Tel: 852-2401-1200
Fax: 852-2401-3431

China - Shanghai

Room 701, Bldg. B
Far East International Plaza
No. 317 Xian Xia Road
Shanghai, 200051
Tel: 86-21-6275-5700
Fax: 86-21-6275-5060

China - Shenzhen

Rm. 1812, 18/F, Building A, United Plaza
No. 5022 Binhe Road, Futian District
Shenzhen 518033, China
Tel: 86-755-82901380
Fax: 86-755-8295-1393

China - Shunde

Room 401, Hongjian Building, No. 2
Fengxiangnan Road, Ronggui Town, Shunde
District, Foshan City, Guangdong 528303, China
Tel: 86-757-28395507 Fax: 86-757-28395571

China - Qingdao

Rm. B505A, Fullhope Plaza,
No. 12 Hong Kong Central Rd.
Qingdao 266071, China
Tel: 86-532-5027355 Fax: 86-532-5027205

India

Divyasree Chambers
1 Floor, Wing A (A3/A4)
No. 11, O'Shaughnessy Road
Bangalore, 560 025, India
Tel: 91-80-22290061 Fax: 91-80-22290062

Japan

Benex S-1 6F
3-18-20, Shinyokohama
Kohoku-Ku, Yokohama-shi
Kanagawa, 222-0033, Japan
Tel: 81-45-471- 6166 Fax: 81-45-471-6122

Korea

168-1, Youngbo Bldg. 3 Floor
Samsung-Dong, Kangnam-Ku
Seoul, Korea 135-882
Tel: 82-2-554-7200 Fax: 82-2-558-5932 or
82-2-558-5934

Singapore

200 Middle Road
#07-02 Prime Centre
Singapore, 188980
Tel: 65-6334-8870 Fax: 65-6334-8850

Taiwan

Kaohsiung Branch
30F - 1 No. 8
Min Chuan 2nd Road
Kaohsiung 806, Taiwan
Tel: 886-7-536-4818
Fax: 886-7-536-4803

Taiwan

Taiwan Branch
11F-3, No. 207
Tung Hua North Road
Taipei, 105, Taiwan
Tel: 886-2-2717-7175 Fax: 886-2-2545-0139

EUROPE

Austria

Durisolstrasse 2
A-4600 Wels
Austria
Tel: 43-7242-2244-399
Fax: 43-7242-2244-393

Denmark

Regus Business Centre
Lautrup høj 1-3
Ballerup DK-2750 Denmark
Tel: 45-4420-9895 Fax: 45-4420-9910

France

Parc d'Activite du Moulin de Massy
43 Rue du Saule Trapu
Batiment A - Ier Etage
91300 Massy, France
Tel: 33-1-69-53-63-20
Fax: 33-1-69-30-90-79

Germany

Steinheilstrasse 10
D-85737 Ismaning, Germany
Tel: 49-89-627-144-0
Fax: 49-89-627-144-44

Italy

Via Quasimodo, 12
20025 Legnano (MI)
Milan, Italy
Tel: 39-0331-742611
Fax: 39-0331-466781

Netherlands

Waegenburghtplein 4
NL-5152 JR, Drunen, Netherlands
Tel: 31-416-690399
Fax: 31-416-690340

United Kingdom

505 Eskdale Road
Winnersh Triangle
Wokingham
Berkshire, England RG41 5TU
Tel: 44-118-921-5869
Fax: 44-118-921-5820

05/28/04