

atrin **electronic**

Expertise, variety and quality



www.atrinelec.com

آترین الکترونیک

تخصص، تنوع و کیفیت

۰۲۱۶۶۷۰۳۶۵۲



Info@Atrinelec.com



تهران، پاساژ امجد، طبقه اول، واحد ۱۶



@ATRINELEC



RAMPS 1.4 Assembly Guide

3D Printer Czar

Version 1

Table of Content

Getting to know RAMPS 1.4 -----	3
Insert jumpers to RAMPS 1.4-----	4
Connect the boards-----	4
Crimp Connectors-----	5
Connect the Power Supply-----	6
Connect the Rest-----	7

Getting to know RAMPS 1.4

RAMPS 1.4 is probably the most widely used electronics for RepRap machines as of March 2014. It consists of a RAMPS 1.4 shield, an Arduino Mega 2560 board (or a clone), and a max of five Pololu Stepper drivers. It can control up to 5 stepper motors with 1/16 stepping precision and interface with a hotend, a heatbed, a fan (or a second hotend), a LCD controller, a 12V (or 24V with appropriate modification) power supply, up to three thermistors, and up to six end stoppers.

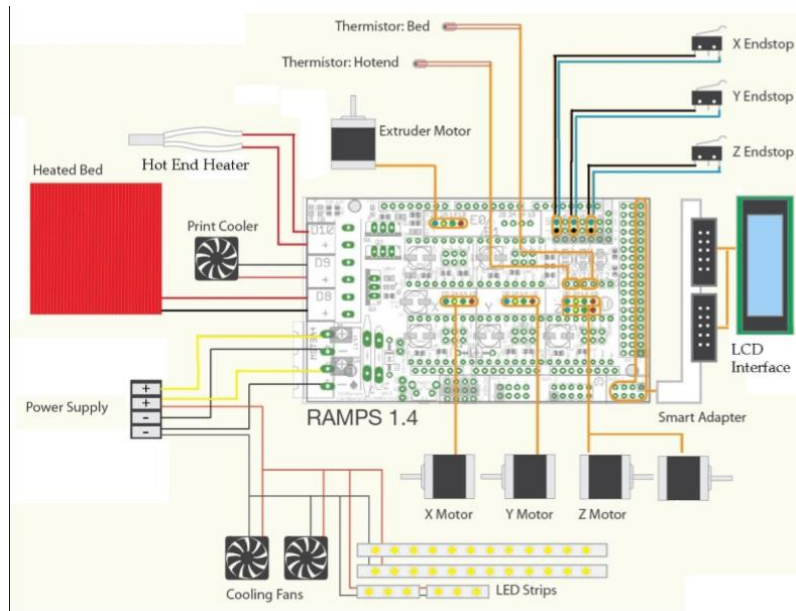

RAMPS 1.4 Schematic, taken from www.makerfarm.com

1. Insert jumpers to RAMPS 1.4

The jumpers (in the plastic bag below) control the precision of the motor movement. To have the most precise stepping (1/16 micro stepping), insert three jumpers to each of the areas outlined below:

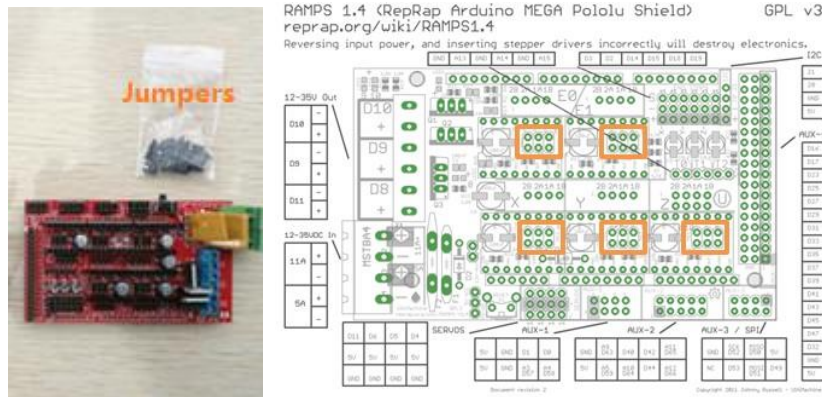

Install all jumpers to the orange area to ensure the most precise stepping

If you would like to learn about other modes of stepping (full stepping, half stepping, 1/8 stepping, etc.), please refer to this article: <http://www.nmbtc.com/step-motors/engineering/full-half-and-microstepping.html>. These modes are not suitable for 3D printer motion control, but could be useful for other projects.

2. Connect the Boards

Stack the RAMPS 1.4 shield on top of the Arduino Mega 2560 board. Make sure the orientation is correct as shown above. The Mega 2560 board's USB side is directly under RAMPS 1.4 shield's "D8 D9 D10" area.

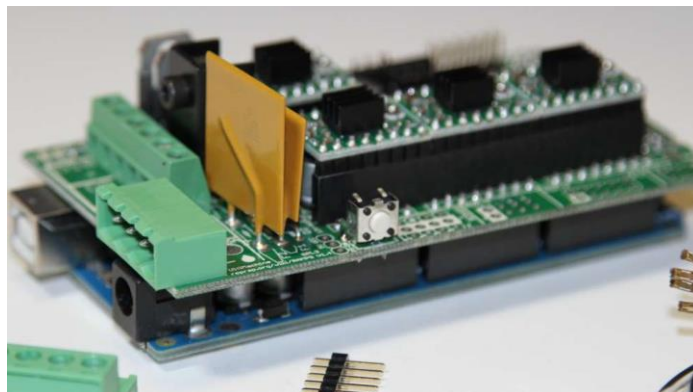

Stack up the RAMPS 1.4 shield on top of Mega 2560 Board

Next stack the Pololu steppers on top of the RAMPS 1.4 shield. **MAKE SURE THE ORIENTATION IS CORRECT AS SHOWN BELOW!** The potential meter (outlined in red on the right picture below) should be facing away from the “D10 D9 D8” side on the RAMPS 1.4 shield. We have heard numerous cases where these steppers got fried because of incorrect orientation. Install the heat sinks on the Pololu steppers, and make sure the heat sink are not touching multiple components on the Pololu stepper (the clearance could be small, but it is there!)

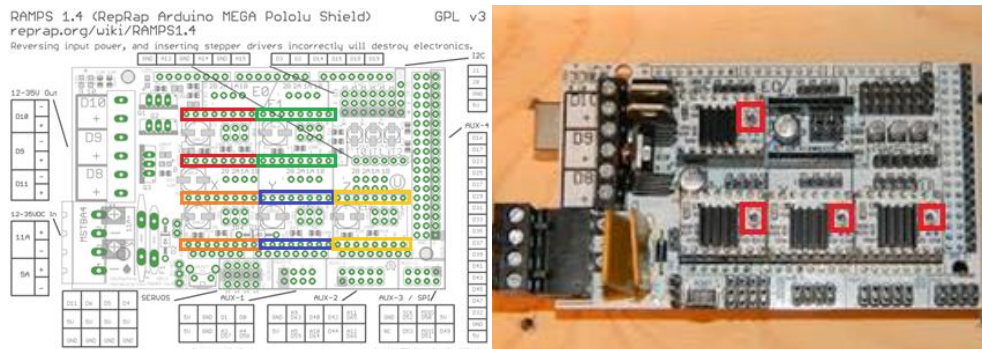

Install the Five Pololu steppers in the boxed pins shown on the left picture. Make sure the Potentiometer on the Pololu stepper is away from the side labeled “D10 D9 D8”.

3. Crimp Connectors

Motors, hotend thermistor, and the heatbed thermistor have bare wires. You need to crimp the Dupont connector pins and attach the connector shells. It might be easy to use a crimping tool (the best place to find one is Ebay or Radio shack), but needle nose pliers also work. This Instructables article gives a detailed step by step guide to crimping connectors:

<http://www.instructables.com/id/How-to-Make-A-Quality-Crimped-Joint/>

When crimping the motor connectors, follow the **Black-Green-Blue-Red** order. If you find the motor spinning the opposite direction later, simply disconnect and flip the connector (make sure you do this while the power is off, otherwise you risk frying the Pololu boards).

The thermistor connector does not have a particular orientation.

4. Connect the Power Supply

If you are in a region with 110V outlet, first open the case and and switch to the 110V mode.



Switch to the correct voltage before use.

Cut the end of the power plug (not included in the kit) to reveal the three wires: Brown, Blue, Green (you might get a different set of colors depending on your power plug. If that's the case, use a multi-meter to determine the L, N, and G nodes). Strip these wires and connect them to the power supply unit's L, N, G nodes respectively. Untighten the screws and slide the stripped wires underneath, and retighten them. Give the wires a gentle pull to make sure they are tightened properly.

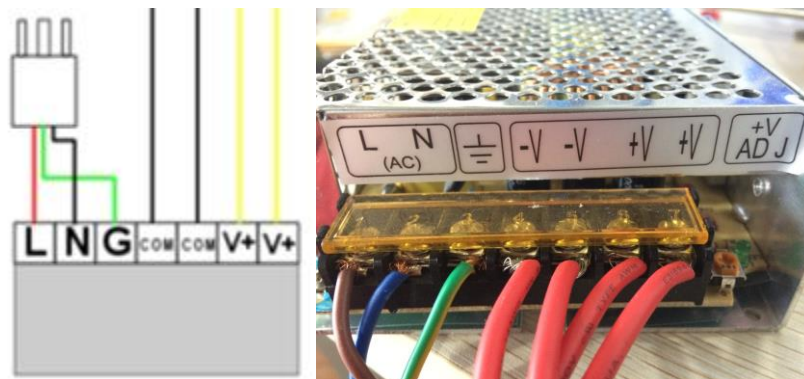

Get four spare wires and connect them on the two Com(V-) and the two V+ nodes. Connect the other ends to the RAMPS 1.4 shield's power input nodes:

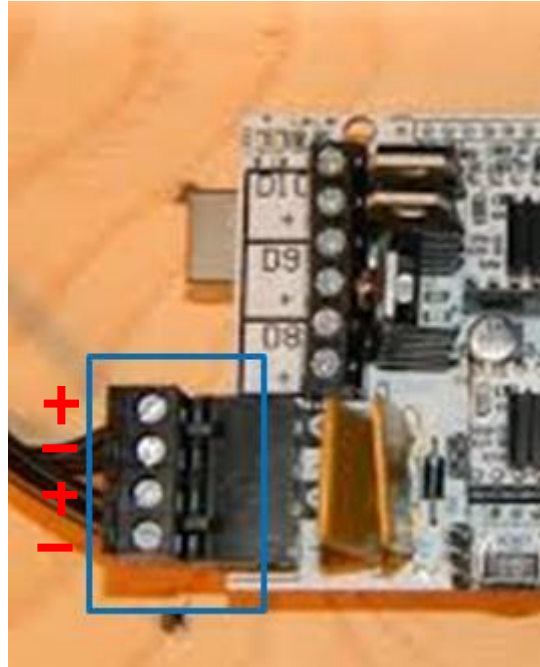

The first one on the bottom is COM(-V), then V+, then Com, then V+ again as shown above.

5. Connect Motors, Thermistors, Hotend, Heatbed, and Fan.

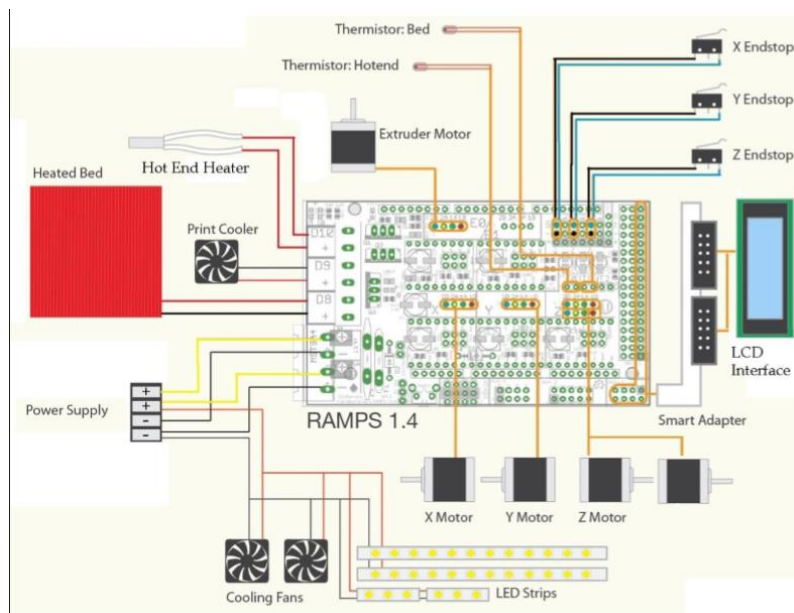

If you find motors spinning in a different direction, please switch the power off and simply flip the motor connector. There are two connectors in parallel for Z axis, since most RepRap machines use two motors to move in Z direction.

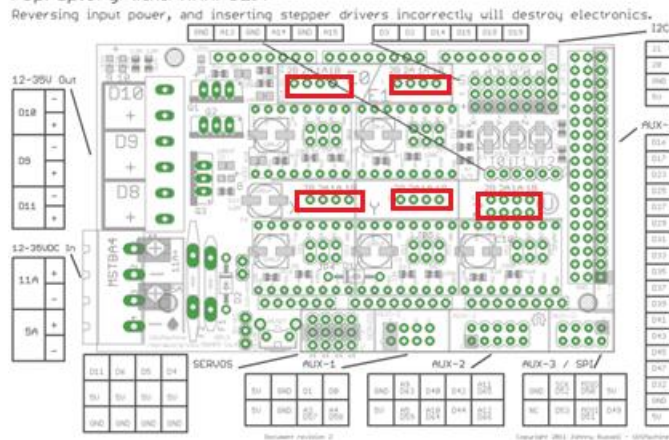

Top left: extruder 1. Top right: extruder 2. Bottom left: X-motor. Bottom middle: Y-motor. Bottom right: Z-motors.

There are three thermistor connector pins. From left to right: extruder 1, heatbed, and extruder 2. These are not polarity-sensitive.

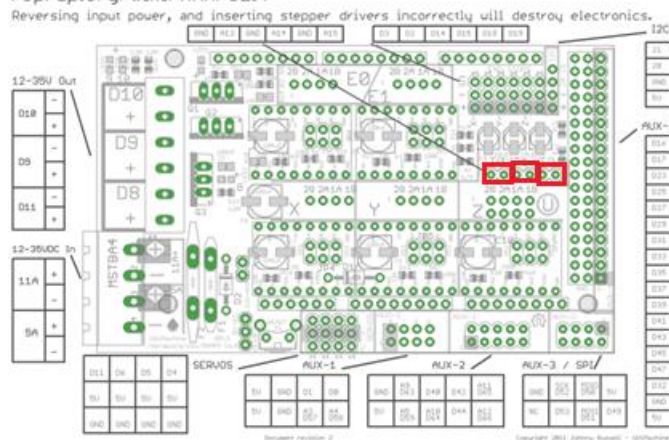

From left to right: Extruder 1 thermistor, heat bed thermistor, and extruder 2 thermistor

Plug in extruder 1 heater to D10, heatbed heater to D8, and fan(or a second extruder) to D9. Only the fan is polarity-sensitive.

RAMPS 1.4 (RepRap Arduino MEGA Pololu Shield)
reprap.org/wiki/RAMPS1.4

GPL v3

Reversing input power, and inserting stepper drivers incorrectly will destroy electronics.

