

**atrin** **electronic**

Expertise, variety and quality



www.atrinelec.com

**آترین الکترونیک**

تخصص، تنوع و کیفیت

02166766957 - 02166766927



info@atrinelec.com



تهران پاساژ امجد طبقه 1 واحد 16



@atrinelec



# **RF01D – ID3**

**125 kHz RFID card reader**

**With internal memory**

**&**

**Internal Antenna**

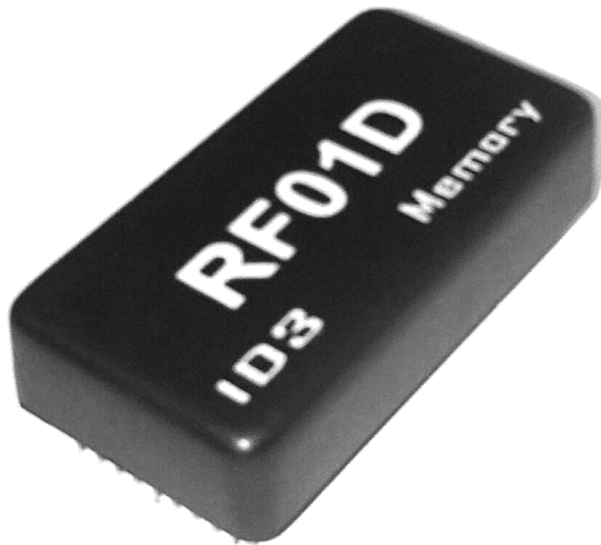

## **DESCRIPTION:**

This is a great little RFID Reader Module from Innovations, similar to the ID models. If you need an inexpensive way to get started with RFID, this is a great little module. Just power the module, and it will read any RFID card within range.

## FEATURES:

- Voltage supply DC5V
- Current consumption <50mA
- 125kHz read frequency
- EM4001/4102 64-bit RFID tag compatible
- Four mode data output (HEX, decimal, decimal point, Card-ID)
- Internal memory for storage 250 cards.
- An output for the card around
- 9600bps TTL output
- 100mm read range

## HARDWARE AND PIN NUMBERS:



RF01D-ID3 (bottom view)

**If the module has an internal antenna, this A1 & A2 pins is not used**

**PIN FUNCTION DESCRIPTION:**

Pin.no	Mnemonic	Function	RD01D-ID3	RD01D-ID3 [Memory]
1	VDD	Power supply voltage	4.7 to 5.5V	4.7 to 5.5V
2	CLOCK/RXD	Output / input	clock / RXD	clock / RXD
3	DATA/TXD	Output	data / TXD	data / TXD
4	AROUND	Output for Relay	see [Figure2]	see [Figure2]
5	SW1	Input	Not use	see [Table 3]
6	SW2	input	select mode 1	select mode 1
7	SW3	Input	select mode 2	select mode 2
8	SW4	Input	Not use	see [Table 3]
9	BUZZER	Buzzer output	see Figure3	see Figure3
10	GND	Power supply GND	GND	GND
11	ANTENNA1	* If the module has an internal antenna, this two pins is not used		
12	ANTENNA2			

Table 1 (PIN FUNCTION)

**INPUT SELECTION PINS RF01D-ID3:**

SW1	SW2	SW3	SW4	OUTPUT DATA
NC	0	0	NC	Ten-digit ID card1 decimal Basis ( <b>0010838980</b> ) 0x30, 0x30, 0x31, 0x30, 0x38, 0x33, .... , 0x13 , 0x10 (Enter)
NC	0	1	NC	RF01D default HEX data (1 <b>1E00A563C4<sup>L</sup></b> ) 0x02 (start byte), 10 HEX data , 0x10 '&' 0x13 (Enter) , 0x03 (Stop byte)
NC	1	0	NC	ID card numbers with decimal-point basis ( <b>165.25540</b> ) 0x31, 0x36, 0x35, 0x2E, 0x32, 0x35, .... , 0x13 , 0x10 (Enter)
NC	1	1	NC	Ten-digit ID card2 decimal Basis ( <b>0010904516</b> ) 0x30, 0x30, 0x31, 0x30, 0x39, 0x30, .... , 0x13 , 0x10 (Enter)

Table 2 (INPUT SELECTION PINS RF01D-ID3)

**INPUT SELECTION PINS RF01D-ID3 [Internal Memory]:**

When the SW1 & SW4 pins is used in negative voltage, module has working in the memory mode

And Opening the relay when the card is identified [Figure2].

SW1	SW2	SW3	SW4	OUTPUT DATA
NC	0	0	NC	Ten-digit ID card1 decimal Basis ( <b>0010838980</b> ) 0x30, 0x30, 0x31, 0x30, 0x38, 0x33, .... , 0x13 , 0x10 (Enter)
NC	0	1	NC	RF01D default HEX data ( $\uparrow$ <b>1E00A563C4<sup>L</sup></b> ) 0x02 (start byte), 10 HEX data , 0x10 '&' 0x13 (Enter) , 0x03 (Stop byte)
NC	1	0	NC	ID card numbers with decimal-point basis ( <b>165.25540</b> ) 0x31, 0x36, 0x35, 0x2E, 0x32, 0x35, .... , 0x13 , 0x10 (Enter)
NC	1	1	NC	Ten-digit ID card2 decimal Basis ( <b>0010904516</b> ) 0x30, 0x30, 0x31, 0x30, 0x39, 0x30, .... , 0x13 , 0x10 (Enter)
0	0	0	0	working the memory mode And Print Ten-digit ID card1 decimal Basis ( <b>0010838980</b> )
0	0	1	0	working the memory mode And Print RF01D default HEX data ( $\uparrow$ <b>1E00A563C4<sup>L</sup></b> )
0	1	0	0	working the memory mode Print ID card numbers with decimal-point basis ( <b>165.25540</b> )
0	1	1	0	working the memory mode And Print 0x30, 0x30, 0x31, 0x30, 0x39, 0x30, .... , 0x13 , 0x10 (Enter)
0	X	X	1	Saving Cards Into memory and sends the card data to serial port
1	X	X	0	Deleting Cards From memory and sends the card data to serial port

Table 3 (INPUT SELECTION PINS RF01D-ID3 [Memory])

[Figure1] TEST CIRCUIT RF01D – ID3 :

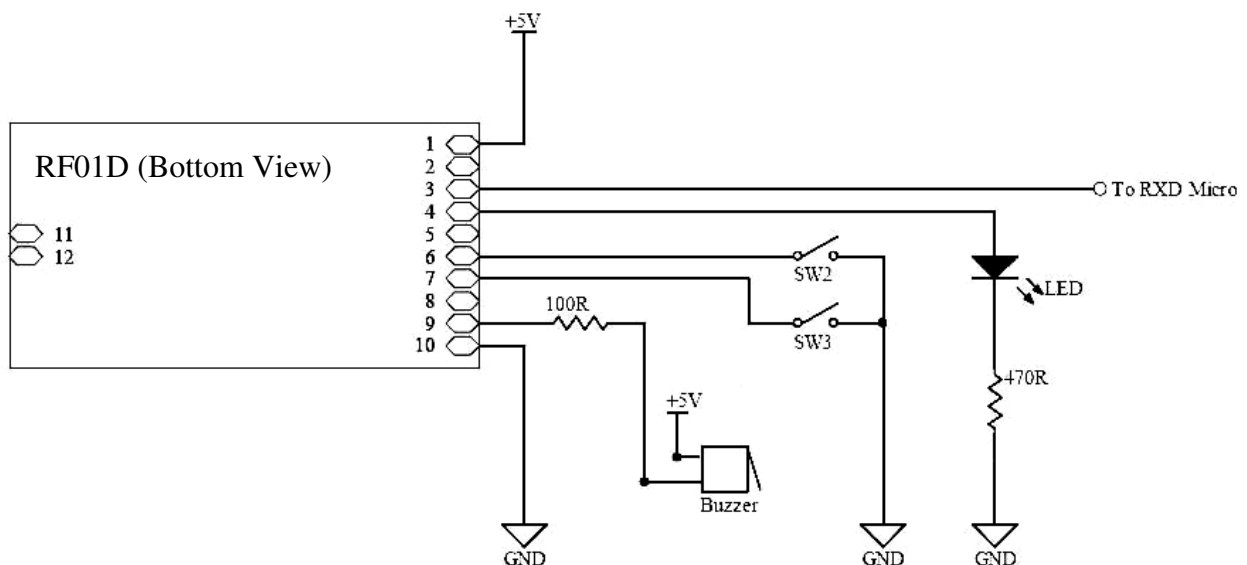

**[Figure2] TEST CIRCUIT RF01D – ID3 [Memory]:**

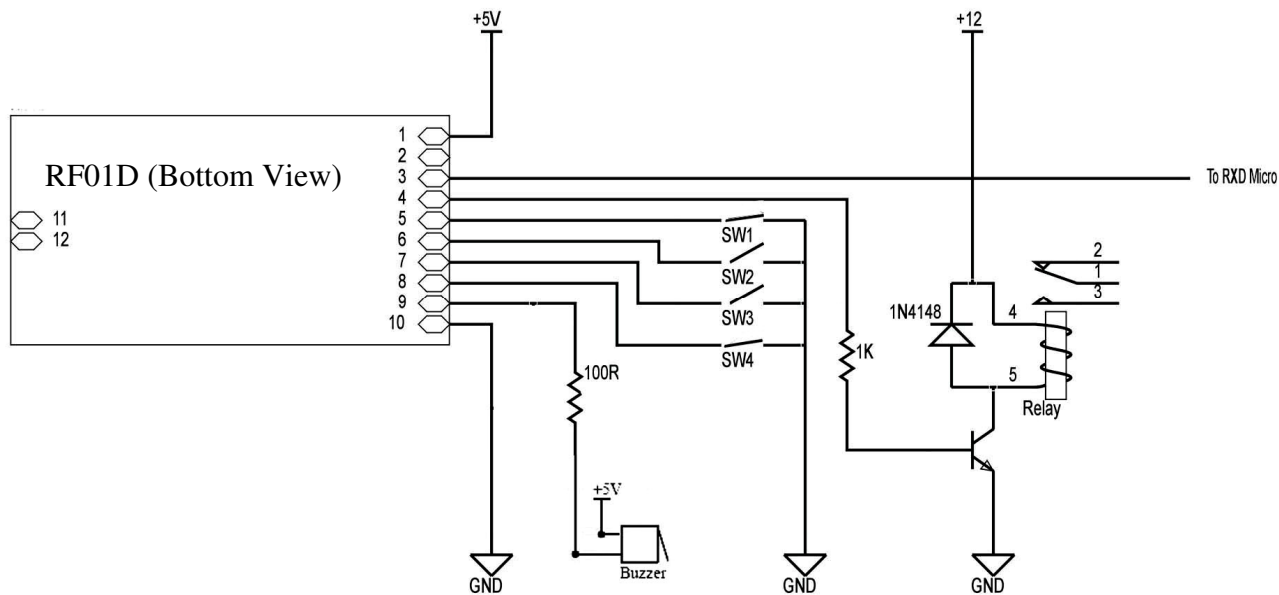

**[Figure3] PACKAGE & PIN SIZE:**

