

atrin **electronic**

Expertise, variety and quality



www.atrinelec.com

آترین الکترونیک

تخصص، تنوع و کیفیت

۰۲۱۶۶۷۰۳۶۵۲



تهران، پاساژ امجد، طبقه اول، واحد ۱۶



Info@Atrinelec.com



@ATRINELEC





WTV020-SD MODULE

WTV020-SD-20S and WTV020-SD-16P

1.PRODUCT FEATURES	2
3.APPLICATION DIAGRAM.....	3
4.APPLICATIONS	3
5.PINS	4
5.1.WTV020-SD-20S	4
5.2.WTV020-SD-16P	5
6.MODULE SELECTION.....	5
7.CONTROL MODES	6
7.1.MP3 MODE.....	6
7.1.1. ON/OFF(PALY/STOP)	6
7.1.2.NEXT	6
7.1.3.PREVIOUS	7
7.2. KEY (3 group of voice)	7
7.2.1. EDGE RETRIGGER	7
7.3.KEY(5 group of voice).....	8
7.3.1. All KEYS ARE EDGE RETRIGGER.....	8
7.3.2.EDGE RETRIGGER TIMING WAVEFORM	8
7.3.3.ALL KEYS ARE ON/OFF(unloop)	9
7.3.4. ALL KEYS ARE ON/OFF(unloop) TIMING WAVEFORM	9
7.3.5. ALL EKYS ARE ON/OFF (loop)	9
7.3.6. ON/OFF(loop) TIMING WAVEFORM.....	9
7.4.LOOP PLAY AFTER POWER ON.....	10
7.4.1.EDGE TRIGGER TO PAUSE/PLAY.....	10
7.4.2. EDGE TIRGGER TO PAUSE/PLAY TIMING WAVEFORM.....	10
7.4.3.LEVEL TRIGGER TO PAUSE/PLAY	11
7.4.4.LEVEL TRIGGER TO PAUSE/PLAY TIMING WAVEFORM.....	11
7.5.TWO LINE SERIAL MODE	11
7.5.1. I/O FUNCTION IN TWO LINE SERIAL MODE.....	11
7.5.2. VOICE ADDRESSES.....	11
7.5.3.TIMING WAVEFORM IN TWO LINE SERIAL MODE	12
7.5.4. CODE DESCRIPTIONS	12
7.5.5. PROGRAM EXAMPLE	13
8.TYPICAL APPLICATION CIRCUIT	18
8.1.WTV020-SD-20S INNER CIRCUIT	18
8.2.WTV020-SD-16P INNER CIRCUIT.....	19
8.3.MP3 MODE APPLICATION CIRCUIT(PWM OUTPUT)	19
8.4.MP3 MODE APPLICATION CIRCUIT(DAC OUTPUT)	20
8.5.KEY MODE(3 group of voice) APPLICATION CIRCUIT(PWM OUTPUT).....	20



8.6.KEY MODE(5 group of voice)APPLICATION CIRCUIT(PWM OUTPUT)	21
8.7.LOOP PLAY AFTER POWER ON(EDGE TRIGGER PAUSE/PLAY) APPLICATION CIRCUIT(PWM OUTPUT)...	21
8.8.LOOP PLAY AFTER POWER ON (LEVEL TRIGGER PAUSE/PLAY)APPLICATION CIRCUIT(PWM OUTPUT)..	22
8.9.TWO LINE SERIAL MODE APPLICATION (PWM OUTPUT)	22
9.VOICE FILES IN SD CARD	23
10. PACKAGE SIZE	23
10.1.WTV020SD-20S	23
10.2.WTV020-SD-16P	24
10.3. WTV020-SD-20S MODULE.....	25
11.SUPPLY INFORMATION.....	26
12.VERSIONS	26

1.PRODUCT FEATURES

- ◎Support 1GB SD card max. or SPI flash 64MB max.
- ◎Support 4 Bit ADCPM format files.
- ◎Sampling rate from 6kHz to 36kHz for AD4 voice format.
- ◎Sampling rate from 6kHz~16kHz for WAV voice format
- ◎16 Bit DAC / PWM audio output.
- ◎Key mode, MP3 mode and two line serial mode are optional .Can choose one of them
- ◎Copy voice files to SD card by PC.
- ◎Working voltage: DC2.7~3.5V
- ◎Quiescent current:: 3uA

2.SUMMARIZE

This module with MP3 mode, key mode(control 3 group of voice with volume adjustment or 5group of voice), two line serial mode, and Loop play mode(after power on ,the module will play loop, with memory function in the mode) They are optional. Customers can choose one of the modes in a module. Also can be customized.

MP3 mode: With play/stop, next , previous, vol+,vol- functions

Key mode(3 group of voice): One key trigger one group of voice,and with vol-, and vol+ . all keys' default trigger modes are edge retrigger

Key mode(5 group of voice): One key trigger one group of voice, trigger mode can be follows: 1. All keys are edge retrigger. 2.All keys are ON/OFF (voice will not cycle after finished) 3.All keys are ON/OFF(voice will cycle after finished)

Loop play mode: After power on , it will play the voices automatically . it doesn't need to trigger the I/O . and with memory function(when you playing voice 2, power was cut off,next time power on it will start from voice 2 or voice 3 .(Can be



customized)

Two line serial mode: WTV020-SD controlled by MCU sending data through CLK and DI . Can play voices in any address, also voices(include mute) can combined to play in this mode.

Change voice by SD card reader and PC. SD card should be FAT format. Sampling rate supported from 6KHz~32KHz and 36KHz for ad4 voice format. 6KHz~16KHz for WAV voice format.

3.APPLICATION DIAGRAM

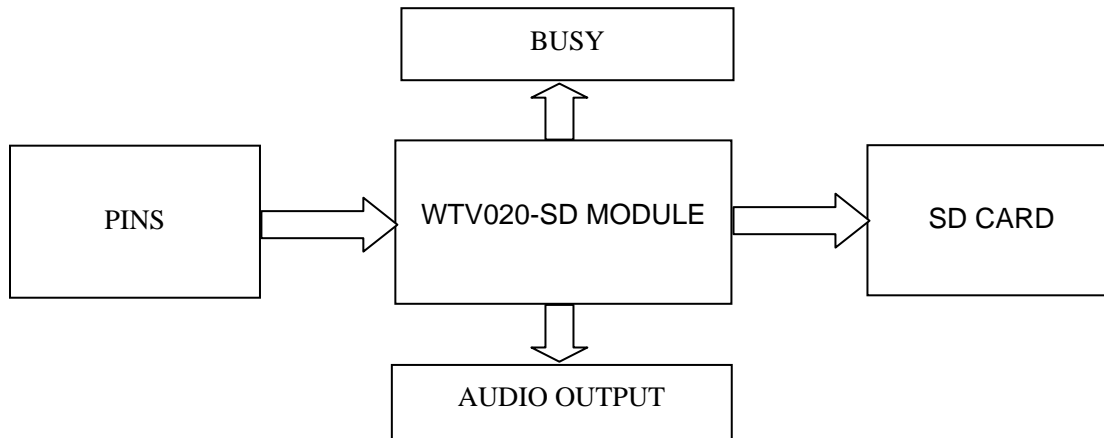

4.APPLICATIONS

This module can use in automobile(car bug, parking radar, GPS navigation system), Intelligent home system, house bug, Voice medical devices, household appliances(induction cooker, rice cooker, micro-wave oven), game machines, learning tools(talking book), Intelligent traffic facilities(toll gate, parking lot), communications equipment(telephone), industrial control(elevator), toys and so on.

5.PINS

5.1.WTV020-SD-20S

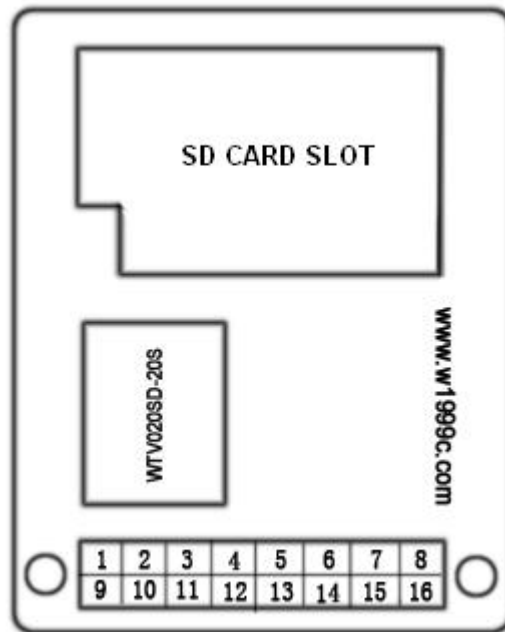

PIN	SYS.	FUNCTION	PIN	SYS.	FUNCTION
1	DC+3.3V	+3.3V	9	GND	GND
2	SPK+	Audio output	10	DC+3.3V	+3.3V
3	P07	I/O	11	SPK+	Audio output
4	P03	I/O	12	SPK-	Audio output
5	NC	NC	13	P06	BUSY
6	NC	NC	14	RST	Reset
7	P02	I/O	15	P04	I/O
8	NC	NC	16	P05	I/O



5.2.WTV020-SD-16P

1	RESET	VDD	16
2	AUDIO-L	P06	15
3	NC	NC	14
4	SPK+	P02	13
5	SPK-	P03	12
6	NC	NC	11
7	P04	P05	10
8	GND	P07	9

PIN	SYS.	DESCRIPTION	FUNCTION
1	RESET	RESET	Reset pin
2	AUDIO-L	DAC+	DAC audio output(+) to amplifier
3	NC	NC	NC
4	SP+	PWM+	PWM audio output to speaker
5	SP-	PWM-	PWM audio output to speaker
6	NC	NC	NC
7	P04	K3/A2/CLK	Key /CLK in two line serial
8	GND	GND	Address pin
9	P07	K5/A4/SBT	Key
10	P05	K4/A3/DI	Key /DI in two line serial
11	NC	NC	NC
12	P03	K2/A1	Key
13	P02	K1/A0	Key
14	NC	NC	NC
15	P06	BUSY	BUSY pin
16	VDD	VDD	Power input

6.MODULE SELECTION

WTV020-SD-20S and WTV020-SD-16P are the same but chip package.

MODE	VOICES	TRIGGER	BUSY	AUDIO	NOTE
MP3	256	KEY	YES	DAC/PWM	
KEY (3 group of voice)	3	KEY	YES	DAC/PWM	EDGE IRRETRIGGER
KEY (5 group of voice)	5	KEY	YES	DAC/PWM	EDGE RETRIGGER
	5	KEY	YES	DAC/PWM	ON/OFF(unloop)



	5	KEY	YES	DAC/PWM	ON/OFF(loop)
LOOP PLAY(after power on)	256	KEY	YES	DAC/PWM	ON/OFF(edge)
	256	KEY	YES	DAC/PWM	ON/OFF(level)
TWO LINE SERIAL	256	BY MCU	YES	DAC/PWM	

7.CONTROL MODES

7.1.MP3 MODE

In the MP3 mode, WTV020-SD module default with 6 I/Os

I/O	P02	P03	P04	P05	P06	P07
FUNCTION	K1	K2	K3	K4	BUSY	K5
TRIGGER	NEXT	PREVIOUS	VOL+	VOL-	-----	ON/OFF

BUSY is for signal output test , when the playing voice, BUSY output is high level, can connect to LED for indicating.

7.1.1. ON/OFF(PALY/STOP)

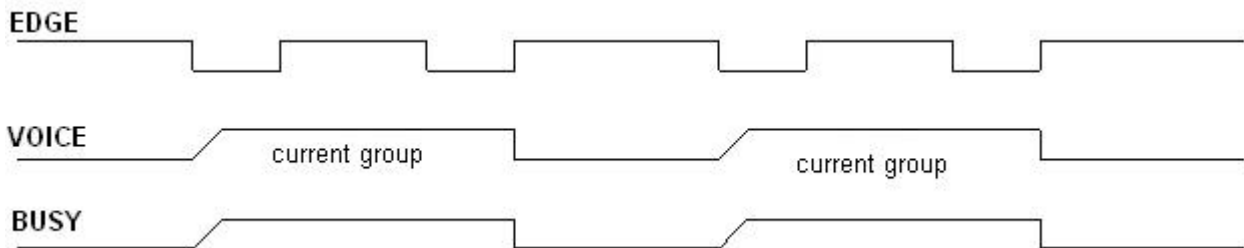

Remark: Edge trigger. A negative edge trigger to play, next negative edge to stop.

7.1.2.NEXT

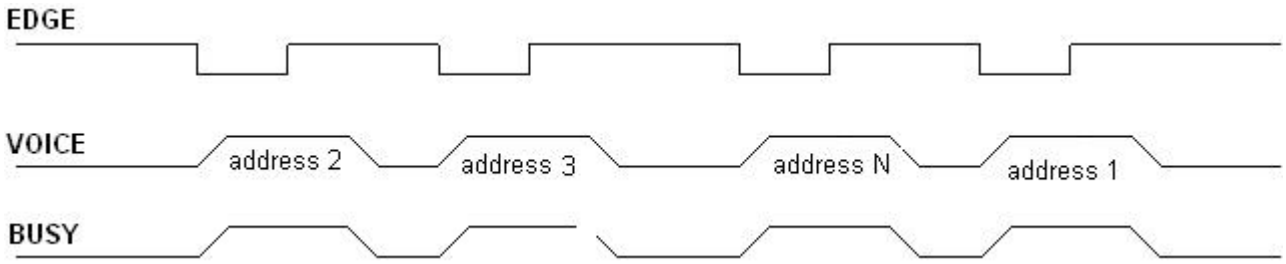

Remark: Edge trigger. One key trigger one group of voice. A negative edge trigger a group of voice, next negative edge trigger next group of voice, after finish last group loop to first group.

7.1.3.PREVIOUS

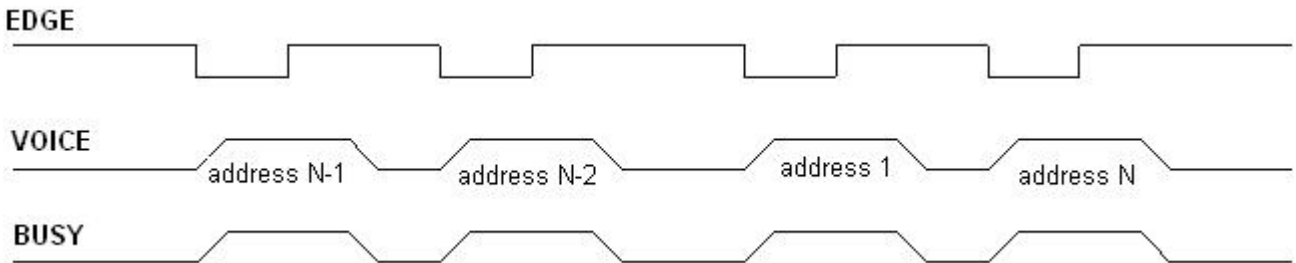

Remark: Edge trigger. One key trigger to play. A negative edge trigger a group of voice, next negative edge trigger previous group of voice, after finish first group loop to last group.

7.2. KEY (3 group of voice)

Pull low P02/P03/P07(short connect P02/P03/P07 with GND) can trigger the 3 group of voices separated , P04 and P05 are for volume adjustment.

I/O	P02	P03	P04	P05	P06	P07
FUNCTION	K1	K2	K3	K4	BUSY	K5
TRIGGER	EDGE IRRTRIGGER	EDGE IRRTRIGGER	VOL+	VOL-	-----	EDGE IRRTRIGGER
VOICE	GROUP 1	GROUP 2	-----	-----	-----	GROUP 3

Key K1~K3 are edge retrigger , BUSY is for signal output test , when the playing voice, BUSY output is high level, can connect to LED for indicating.

7.2.1. EDGE RETRIGGER

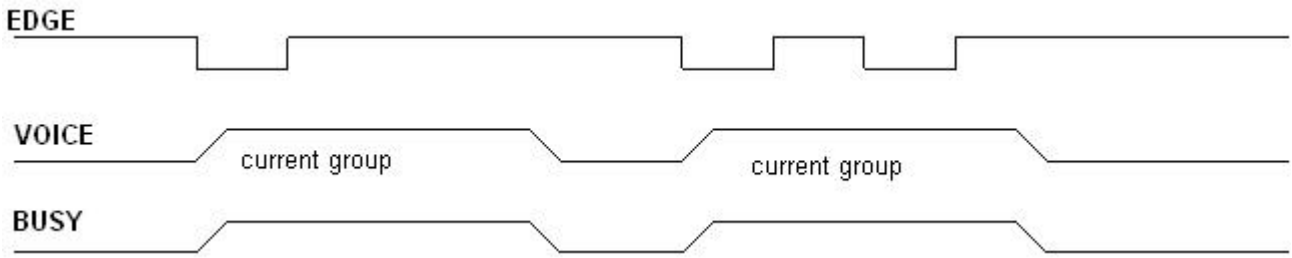

Remark: Edge trigger. When I/O test falling edge(such as this I/O short touch GND) ,the voice will be triggered. During the playing , the next falling edge will not interrupt the voice,after voice play finished,falling edge will make it replay .

7.3.KEY(5 group of voice)

One button trigger one voice , total 5 group of voice , during playing BUSY output is high level, can connect LED to indicate it .

Three optional trigger mode:

- a.All keys are edge retrigger
- b.All keys are ON/OFF(unloop)
- c.All keys are ON/OFF(loop)

7.3.1. ALL KEYS ARE EDGE RETRIGGER

I/O	P02	P03	P04	P05	P06	P07
FUNCTION	K1	K2	K3	K4	BUSY	K5
TRIGGER	EDGE RETRIGGER	EDGE RETRIGGER	EDGE RETRIGGER	EDGE RETRIGGER	-----	EDGE RETRIGGER
VOICE	GROUP 1	GROUP 2	GROUP 3	GROUP 4	-----	GROUP 5

7.3.2.EDGE RETRIGGER TIMING WAVEFORM

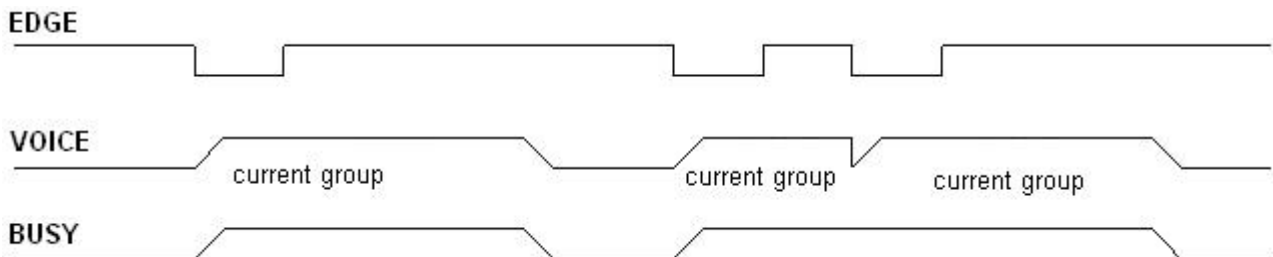

Remark: Edge trigger. When I/O test falling edge(such as this I/O short touch GND) ,the voice will be triggered. During the playing , the next falling edge will interrupt the voice and replay from beginning.

7.3.3. ALL KEYS ARE ON/OFF(unloop)

Trigger I/O(short connect to GND) can play voice ,next trigger make it stop. After voice play finished, it will stop .

I/O	P02	P03	P04	P05	P06	P07
FUNCTION	K1	K2	K3	K4	BUSY	K5
TRIGGER	ON/OFF	ON/OFF	ON/OFF	ON/OFF	-----	ON/OFF
VOICE	GROUP 1	GROUP 2	GROUP 3	GROUP 4	-----	GROUP 5

7.3.4. ALL KEYS ARE ON/OFF(unloop) TIMING WAVEFORM

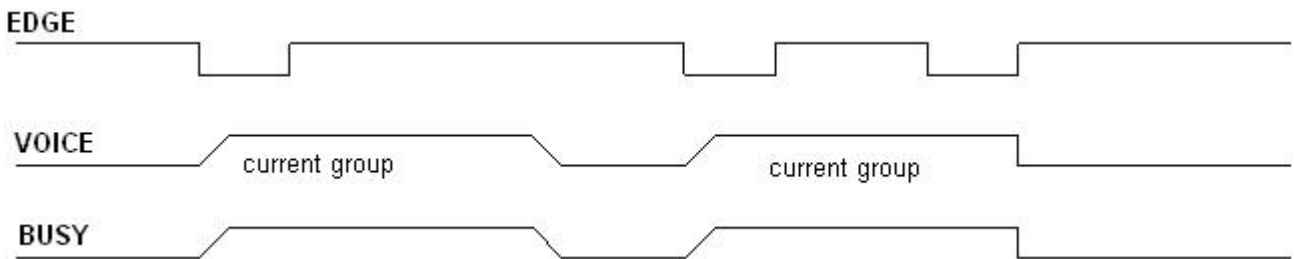

Remark: Edge trigger. When I/O test falling edge(such as this I/O short touch GND) ,the voice will be triggered. After play finished, will stop . During the playing , the next falling edge will stop the voice ,other falling edge will make it play again.

7.3.5. ALL EKYS ARE ON/OFF (loop)

Trigger I/O(short connect to GND) can play voice ,next trigger make it stop. After voice play finished, it will loop .

I/O	P02	P03	P04	P05	P06	P07
FUNCTION	K1	K2	K3	K4	BUSY	K5
TRIGGER	ON/OFF	ON/OFF	ON/OFF	ON/OFF	-----	ON/OFF
VOICE	GROUP 1	GROUP 2	GROUP 3	GROUP 4	-----	GROUP 5

7.3.6. ON/OFF(loop) TIMING WAVEFORM

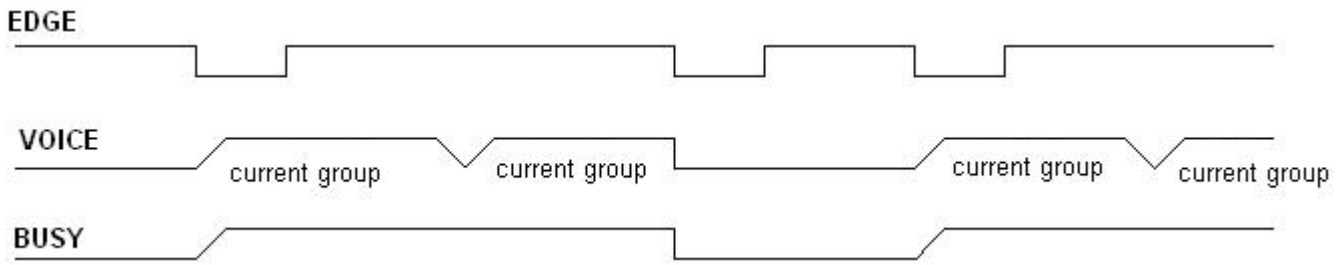

Remark: Edge trigger. When I/O test falling edge(such as this I/O short touch GND) ,the voice will be triggered. After play finished, will cycle play. During the playing , the next falling edge will stop the voice ,other falling edge will make it play again

7.4.LOOP PLAY AFTER POWER ON

After turn on the power, it will play the voice directly, trigger the relative I/O can pause, next trigger will keep playing.In this mode, when the module playing voice 2 and the power was cut off, after turn on power it will play from voice 2 or voice 3(can be customized)

Alternative trigger mode:

- a.Edge trigger to pause /play
- b.Level trigger to pause/play

7.4.1.EDGE TRIGGER TO PAUSE/PLAY

Power on, play voice automatically, negative edge trigger P04 to pause , next trigger to play from the pause point.

I/O	P02	P03	P04	P05	P06	P07
FUNCTION	-----	-----	K1	-----	BUSY	-----
TRIGGER	-----	-----	PAUSE/PLAY	-----	-----	-----
VOICE	-----	-----	ALL VOICE	-----	-----	-----

7.4.2. EDGE TRIGGER TO PAUSE/PLAY TIMING WAVEFORM

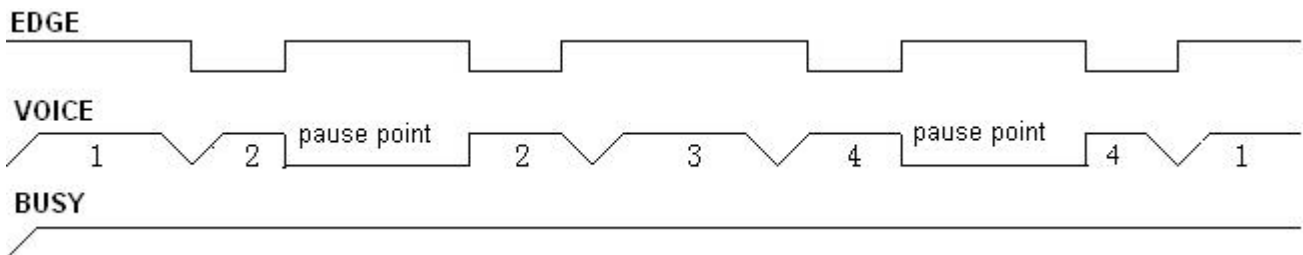

Negative edge trigger. Power on , it will play automatically, negative edge trigger P04 to pause , next trigger to play from the pause point. After voices play finished, it will loop .

7.4.3.LEVEL TRIGGER TO PAUSE/PLAY

Power on , it will play automatically , Low level to trigger P05 to pause, next trigger to play from the pause point.

I/O	P02	P03	P04	P05	P06	P07
FUNCTION	-----	-----	-----	K1	BUSY	-----
TRIGGER	-----	-----	-----	PAUSE/PLAY	-----	-----
VOICE	-----	-----	-----	ALL VOICE	-----	-----

7.4.4.LEVEL TRIGGER TO PAUSE/PLAY TIMING WAVEFORM

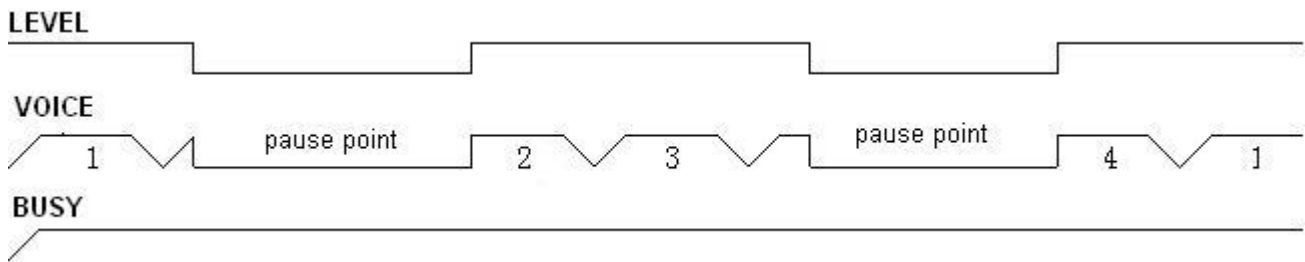

Negative level trigger. Power on , it will play automatically, negative level trigger P05 to pause , next trigger to play from the pause point. After voices play finished, it will loop .

7.5.TWO LINE SERIAL MODE

In the two line serial mode ,there are two communication port, they are CLK and DI. In addition, there is a reset port, 1 second after reset , if no action to the module, the chip will be into standby status within one second if no action after reset.

7.5.1、 I/O FUNCTION IN TWO LINE SERIAL MODE

I/O	P02	P03	P04	P05	P06	P07
FUNCTION	K1	K2	CLK	DI	BUSY	K3
TRIGGER	NEXT	PREVIOUS			-----	PALY/STOP

7.5.2. VOICE ADDRESSES



512 group of voice can be loaded in SD card. The voice file name are decimal , such as 0000.ad4, 0001.ad4,When the MCU send data to trigger, the data should be binary data corresponding to voice file name. MCU send signal to CLK and ID at the same time. DI data send high first, then low. When there is no data, CLK and DI are high level.

ADDRESSES	TRIGGER STATE	FILE NAME(.ad4)	TRIGGER DATA (BINARY)
ADDR 1	PLAY 1 th GROUP VOICE	0000	0000000000000000
ADDR 2	2 nd	0001	0000000000000001
ADDR 3	3 rd	0002	0000000000000010
ADDR 4	4 th	0003	0000000000000011
.....
ADDR 509	509 th	0508	0000000111111100
ADDR 510	510 th	0509	0000000111111101
ADDR 511	511 th	0510	0000000111111110
ADDR 512	512 th	0511	0000000111111111

7.5.3.TIMING WAVEFORM IN TWO LINE SERIAL MODE

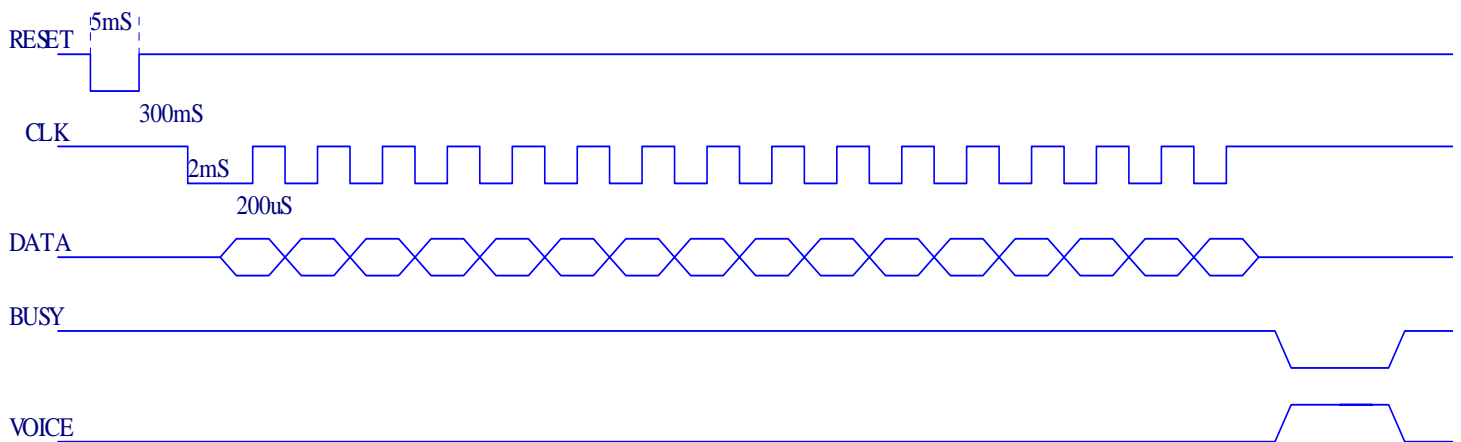

7.5.4. CODE DESCRIPTIONS

CODE	FUNCTION	DESCRIPTION
FFF0H~FFF7H	VOICE VOLUME ADJUSTMENT	THE VOLUME CAN BE ADJUSTED DURING PLAY OR STAND BY STATUS. FFF0H IS MIN, FFF7H IS MAX, TOTAL 8 LEVEL .
FFFEH	PALY/PAUSE	PLAY/PAUSE THE VOICE IN THE ADDRESS
FFFFH	STOP	STOP TO PLAY THE VOICE

The default volume is maximum. FFF0H is mute. Volume can be adjusted in play or stop status.



7.5.5. PROGRAM EXAMPLE

```
ORG 0000H
    KEY EQU P1.1      ; KEY PIN
    KEY2 EQU P1.2    ; VOLUME
    KEY3 EQU P1.3    ; CLK+
    KEY4 EQU P1.6    ; CLK-
    KEY5 EQU P1.7    ; TRANSMIT VOLUME, THEN ADDRESS
    LED EQU P3.0     ; SHOW KEY PRESSED
    SCL EQU P3.2     ; CLK PIN
    SDA EQU P3.3     ; DATA PIN
    RST EQU P3.4     ; RESET PIN
    DAIFAZHI EQU 50H ; SEND CODE VALUE TEMP
    VOICENUM EQU 51H ; VOLUME
    CLKNUM EQU 52H   ; CLK
    MOV DAIFAZHI, #0H ; INITIAL SEND VALUE 0
    MOV VOICENUM, #0F0H ; VOLUME INITIAL VALUE F0H
    MOV CLKNUM, #2    ; DEFAULT SEND CODE 1MS
    MOV R5, #8        ; LOOP EIGHT TIMES
    SETB SCL
    SETB SDA
    SETB RST
MAIN:
    JB KEY, KEY22
    CLR LED
    MOV R6, #5        ; DELAY 10MS
    LCALL DELAY2MS
    JB KEY, KEY22    ; KEY PRESS DEBOUNCE
    JNB KEY, $       ; WAIT KEY PRESSED RELEASE
    SETB LED
    LCALL RESET
    LCALL TWO_LINE   ; TWO LINE SEND CODE SUBPROGRAM
    INC DAIFAZHI     ; CODE VALUE ADD 1
    MOV A, DAIFAZHI
    CJNE A, #37, XX2 ; WHETHER VOLUME REACH MAX. VALUE 128
XX2: JC KEY22
    MOV DAIFAZHI, #0H
KEY22:
    JB KEY2, KEY33
    CLR LED
    MOV R6, #5        ; DELAY 10MS
    LCALL DELAY2MS
```



```
    JB KEY2,KEY33      ;KEY PRESS DEBOUNCE
    JNB KEY2,$         ;WAIT KEY PRESSED RELEASE
    SETB LED
    LCALL RESET
    LCALL VOICE        ;TWO LINE SEND CODE SUBPROGRAM
    INC VOICENUM       ;CODE VALUE ADD 1
    MOV A,VOICENUM
    CJNE A,#0F8H,XX4   ;WHETHER VOLUME REACH MAX. VALUE
XX4: JC KEY33
    MOV VOICENUM,#0F0H
KEY33:
    JB KEY3,KEY44
    CLR LED
    MOV R6,#5          ;DELAY 10MS
    LCALL DELAY2MS
    JB KEY3,KEY44      ; KEY PRESS DEBOUNCE
    JNB KEY3,$         ;WAIT KEY PRESSED RELEASE
    NOP
    INC CLKNUM
    SETB LED
KEY44:
    JB KEY4,KEY55
    CLR LED
    MOV R6,#5          ; DELAY 10MS
    LCALL DELAY2MS
    JB KEY4,KEY55      ; KEY PRESS DEBOUNCE
    JNB KEY4,$         ;WAIT KEY PRESSED RELEASE

    NOP
    DEC CLKNUM
    MOV A,CLKNUM
    CJNE A,#0H,XX5    ; SEND CODE KEEP 100US AT LEAST
    MOV CLKNUM,#1
XX5:
    SETB LED
KEY55:
    JB KEY5,MAIN
    CLR LED
    MOV R6,#5          ; DELAY 10MS
    LCALL DELAY2MS
    JB KEY5,XX6        ;WAIT KEY PRESSED RELEASE
    JNB KEY5,$         ;WAIT KEY PRESSED RELEASE
```



```
LCALL RESET
MOV VOICENUM,#0F6H
LCALL VOICE
LCALL TWO_LINE
XX6:
LJMP MAIN
TWO_LINE:          ;///VOICE ADDRESS SEND CODE SUBPROGRAM
    CLR SCL
    MOV R6,#2
    LCALL DELAY1MS
    MOV A,#0
LOOP1:
    CLR SCL
    RLC A
    MOV SDA,C
    MOV R6,CLKNUM
    LCALL DELAY50US
    SETB SCL
    MOV R6,CLKNUM
    LCALL DELAY50US
    DJNZ R5,LOOP1
    MOV R5,#08H
    MOV A,DAIFAZHI
LOOP2:
    CLR SCL
    RLC A
    MOV SDA,C
    MOV R6,CLKNUM
    LCALL DELAY50US
    SETB SCL
    MOV R6,CLKNUM
    LCALL DELAY50US
    DJNZ R5,LOOP2
    MOV R5,#08H
    RET
VOICE:            ;///VOLUME VALUE SEND CODE SUBPROGRAM
    CLR SCL
    MOV R6,#2
    LCALL DELAY1MS
    MOV A,#0FFH
LOOP3:
```



```
CLR SCL
RLC A
MOV SDA,C
MOV R6,CLKNUM
LCALL DELAY50US
SETB SCL
MOV R6,CLKNUM
  LCALL DELAY50US
DJNZ R5,LOOP3
MOV R5,#08H
MOV A,VOICENUM
```

LOOP4:

```
CLR SCL
RLC A
MOV SDA,C
MOV R6,CLKNUM
LCALL DELAY50US
SETB SCL
MOV R6,CLKNUM
LCALL DELAY50US
DJNZ R5,LOOP4
MOV R5,#08H
RET
```

RESET:

```
CLR RST
MOV R6,#3
LCALL DELAY1MS
SETB RST
MOV R6,#130
LCALL DELAY2MS
```

RET

DELAY2MS: ;DELAY 2MS SUBPROGRAM, CHANGE R6 VALUE CAN CHANGE DELAY TIME

```
L1:  MOV R7,#248
L2:  NOP
     NOP
     NOP
     NOP
     NOP
     NOP
     NOP
     DJNZ R7,L2
     DJNZ R6,L1
     RET
```



DELAY50US: ; DELAY 25UM SUBPROGRAM, CHANGE R4 VALUE CAN CHANGE DELAY TIME

L11: MOV R7,#6

L22:

NOP

NOP

DJNZ R7,L22

DJNZ R6,L11

RET

DELAY1MS: ; DELAY 1MS SUBPROGRAM, CHANGE R6 VALUE CAN CHANGE DELAY TIME

L31: MOV R7,#240

L32: NOP

NOP

DJNZ R7,L32

DJNZ R6,L31

RET

END

8.2.WTV020-SD-16P INNER CIRCUIT

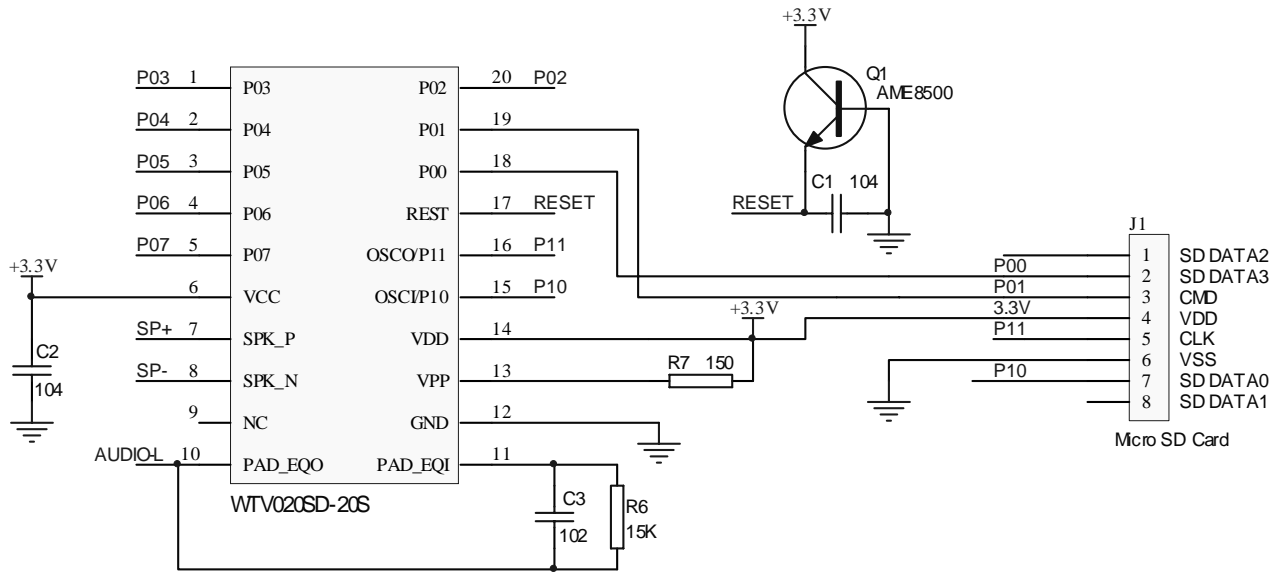

8.3.MP3 MODE APPLICATION CIRCUIT(PWM OUTPUT)

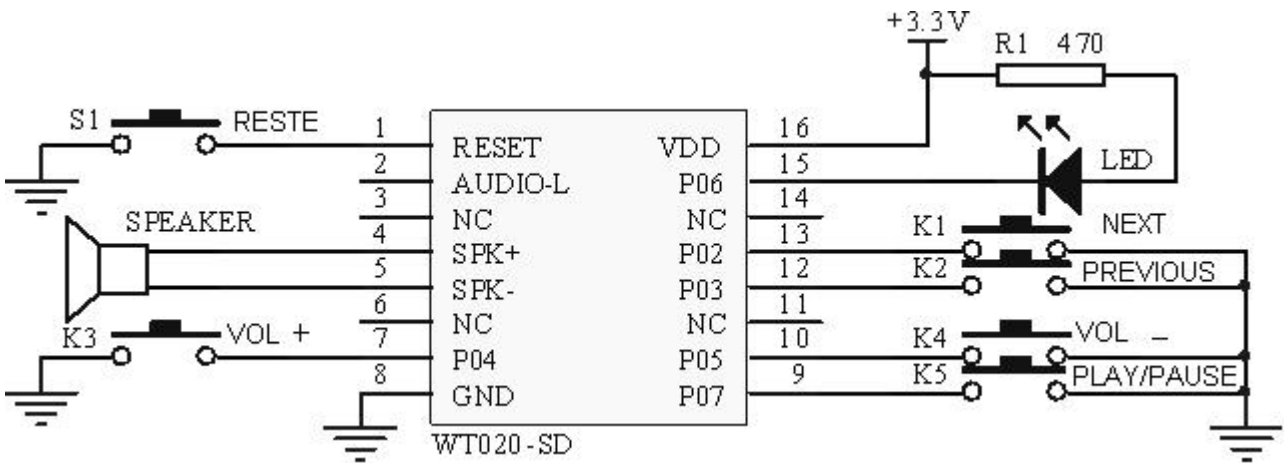

WTV020-SD-16P and WTV020-SD-20S, In PWM output, SPK+ ,SPK- connect to speaker .

In MP3 mode, edge trigger. Control I/Os by key short touch to GND, I/O P02 is PREVIOUS,P03 is NEXT,P04 is VOL+,P05 is VOL-,P07 is PLAY/STOP.

The power input is DC3.3v, if DC5V input, two serial diodes (IN4001 or 4007)connect to the positive input to low the voltage.

8.4.MP3 MODE APPLICATION CIRCUIT(DAC OUTPUT)

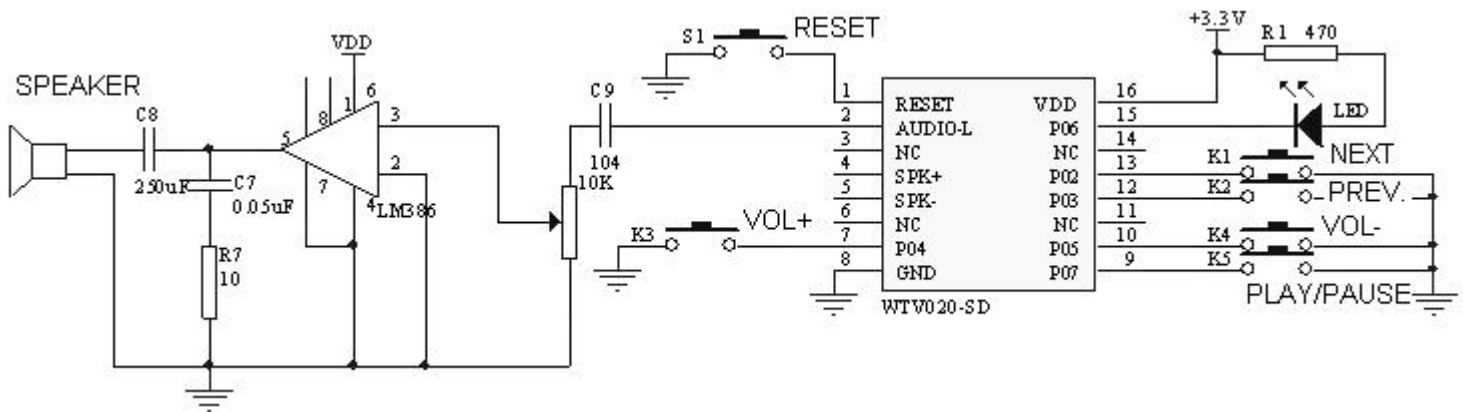

WTV020-SD-16P DAC output, "Audio L" and module GND to amplifier. WTV020-SD-20S DAC output, "SPK+" and module GND to amplifier.

In MP3 mode, edge trigger. Control I/Os by key short touch to GND, I/O P02 is PREVIOUS,P03 is NEXT,P04 is VOL+,P05 is VOL-,P07 is PLAY/STOP.

The power input is DC3.3v, if DC5V input, two serial diodes (IN4001 or 4007)connect to the positive input to low the voltage.

8.5.KEY MODE(3 group of voice) APPLICATION CIRCUIT(PWM OUTPUT)

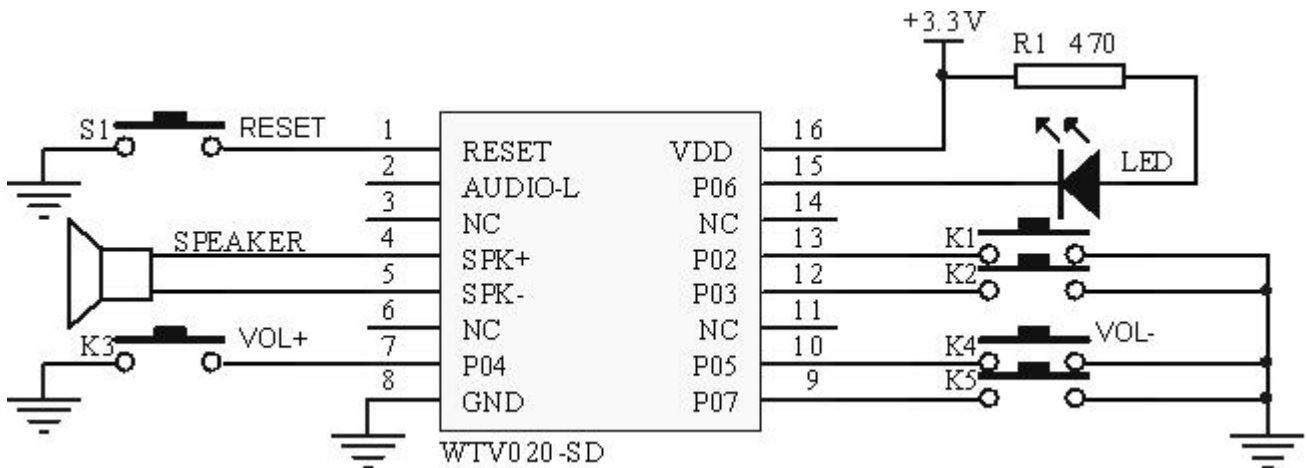

WTV020-SD-16P and WTV020-SD-20S in PWM output, "SPK+" ,"SPK-" to speaker .

In the key mode,edge trigger. GND short touch I/O to trigger voice. P02、 P03、 P04、 P05、 P07 trigger voice 1,voice 2, vol+,vol-,and voice 3 separately.

The power input is DC3.3v, if DC5V input, two serial diodes (IN4001 or 4007)connect to the positive input to low the voltage.

8.6.KEY MODE(5 group of voice)APPLICATION CIRCUIT(PWM OUTPUT)

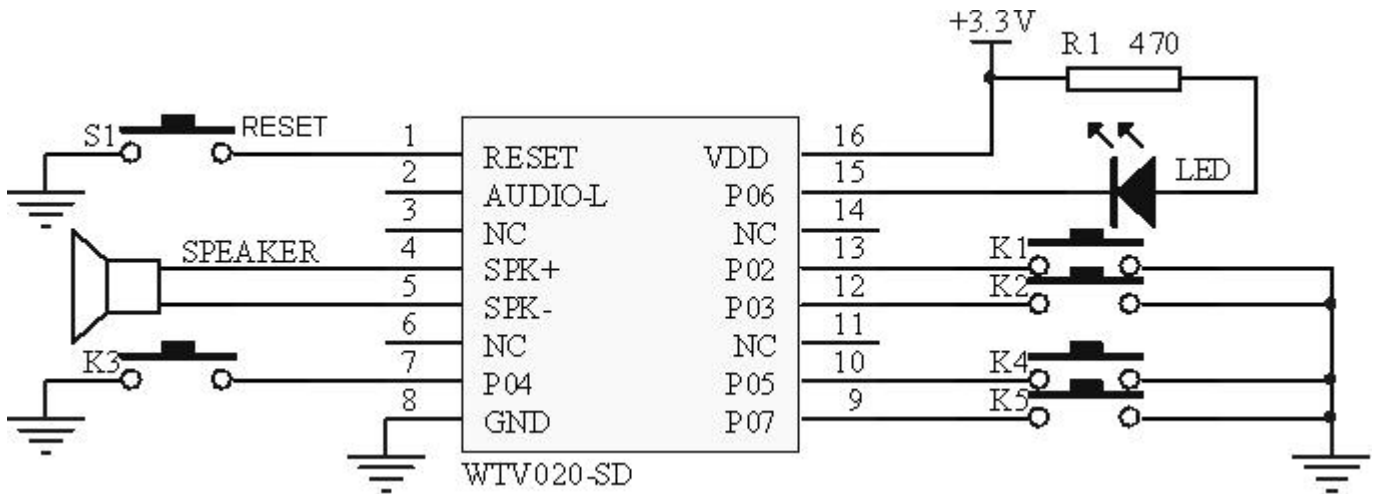

WTV020-SD-16P and WTV020-SD-20S in PWM output, "SPK+" ,"SPK-" to speaker .

In the key mode,edge trigger. GND short touch I/O to trigger voice. P02、P03、P04、P05、P07 trigger voice 1,voice 2, voice 3,voice 4,and voice 5 separately. They are edge retrigger.

The power input is DC3.3v, if DC5v input, two serial diodes (IN4001 or 4007)connect to the positive input to low the voltage.

8.7.LOOP PLAY AFTER POWER ON(EDGE TIRGGER PAUSE/PLAY) APPLICATION CIRCUIT(PWM OUTPUT)

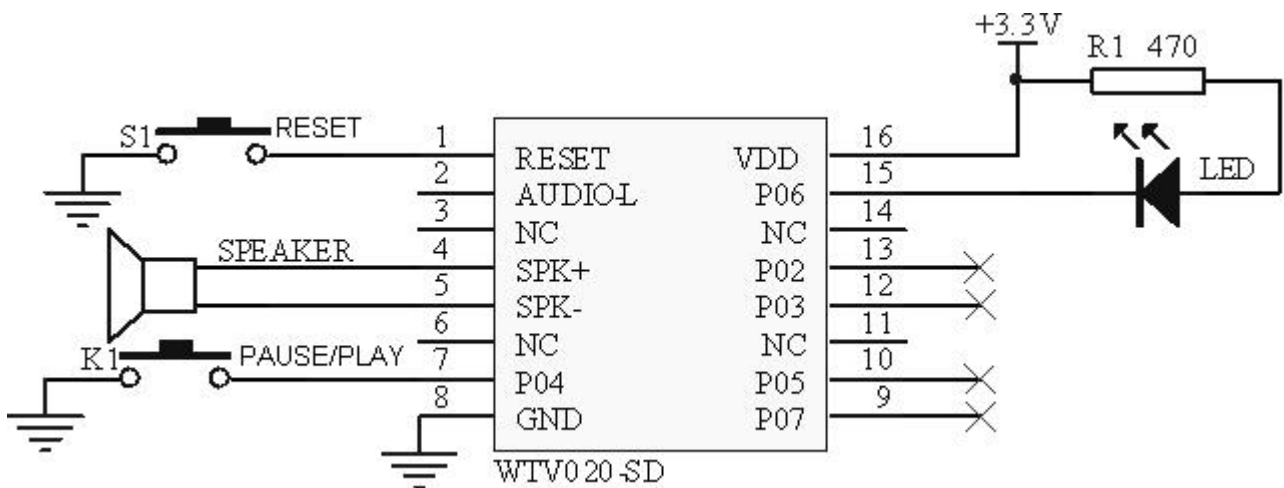

WTV020-SD-16P and WTV020-SD-20S in PWM output, "SPK+" ,"SPK-" to speaker .

In loop play mode,edge trigger. GND short touch I/O to trigger voice. P02、P03、P05、P07 are invalid, P04 trigger pause/play.

The power input is DC3.3v, if DC5v input, two serial diodes (IN4001 or 4007)connect to the positive input to low the voltage.

8.8.LOOP PLAY AFTER POWER ON (LEVEL TRIGGER PAUSE/PLAY)APPLICATION CIRCUIT(PWM OUTPUT)

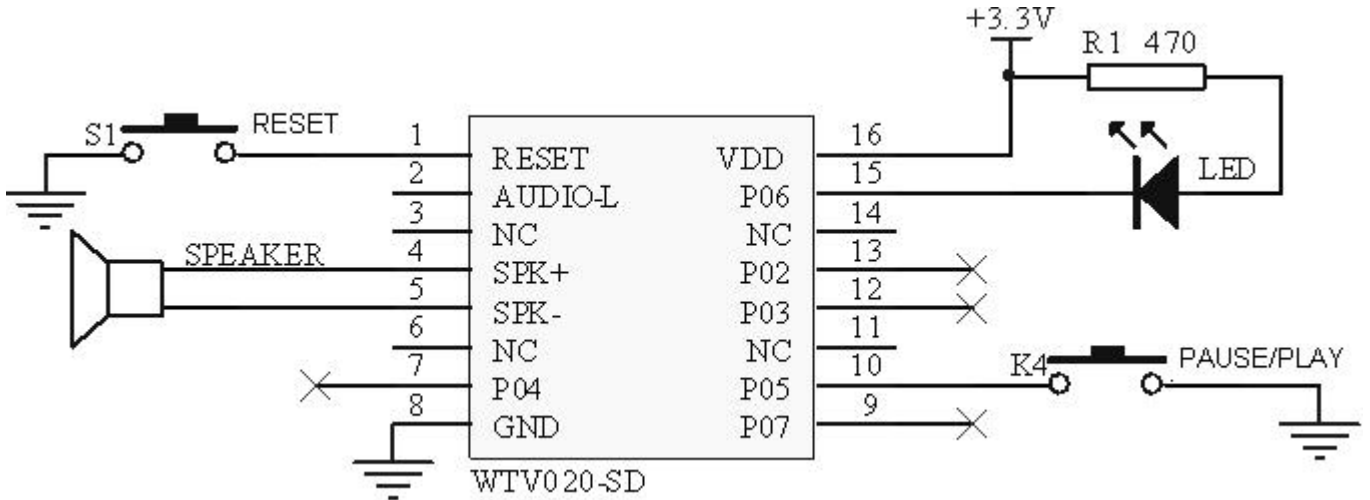

WTV020-SD-16P and WTV020-SD-20S in PWM output, "SPK+" ,"SPK-" to speaker .

In loop play mode,edge trigger. GND short touch I/O to trigger voice. P02、 P03、 P04、 P07 are invalid, P05 trigger pause/play.

The power input is DC3.3v, if DC5V input, two serial diodes (IN4001 or 4007)connect to the positive input to low the voltage.

8.9.TWO LINE SERIAL MODE APPLICATION (PWM OUTPUT)

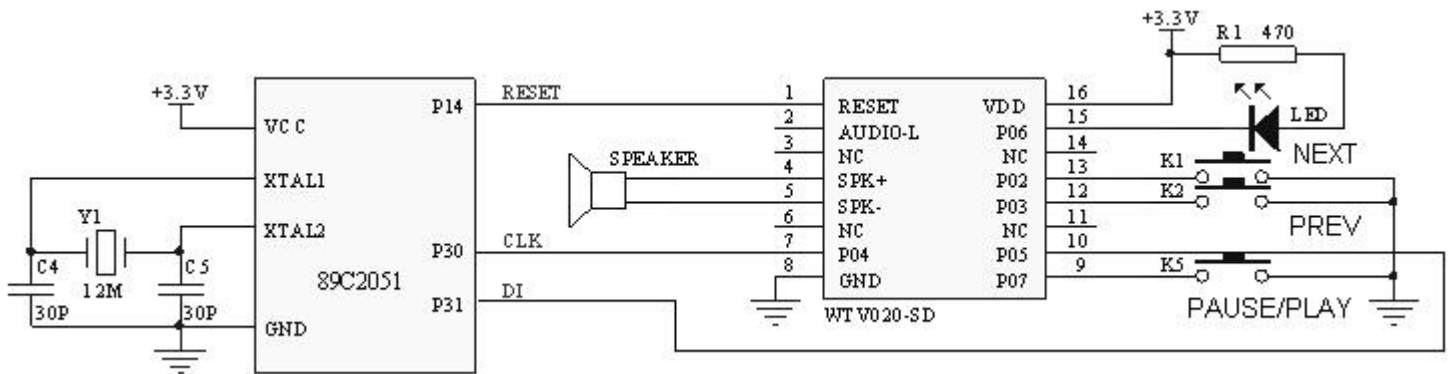

WTV020-SD-16P and WTV020-SD-20S in PWM output, "SPK+" ,"SPK-" to speaker .

In the two line serial mode, edge trigger. MCU control I/O, P02 is next, P03 is previous, P07 is pause/play.

The power input is DC3.3v, if DC5V input, two serial diodes (IN4001 or 4007)connect to the positive input to low the voltage.

10.2.WTV020-SD-16P

Package: DIP16

Unit: mm

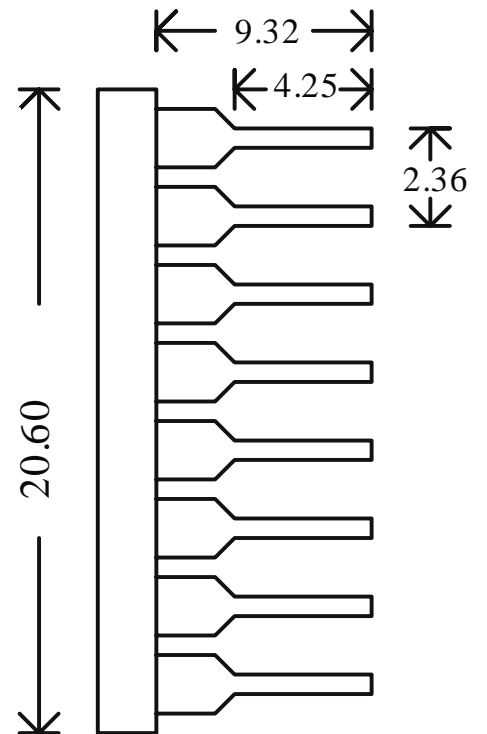
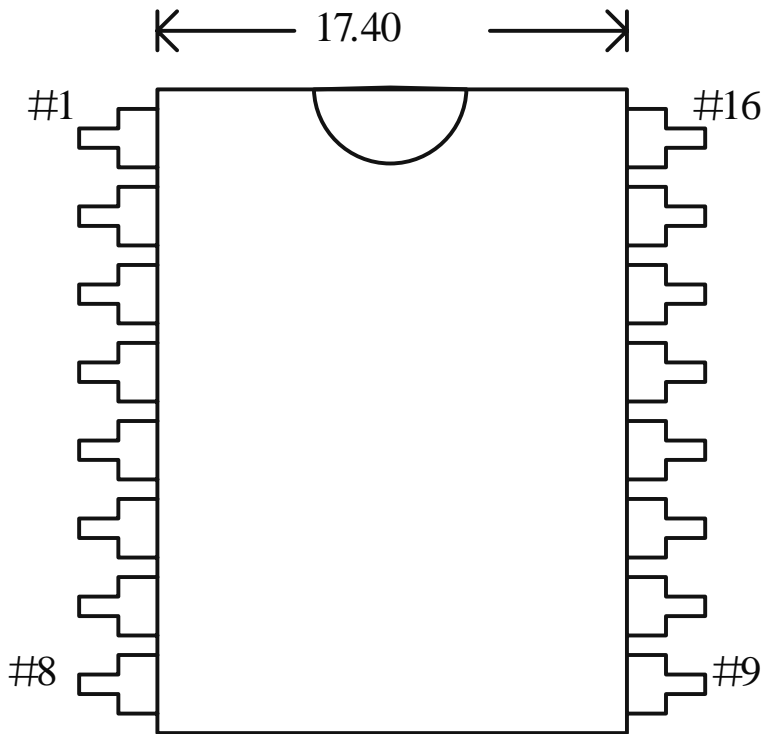



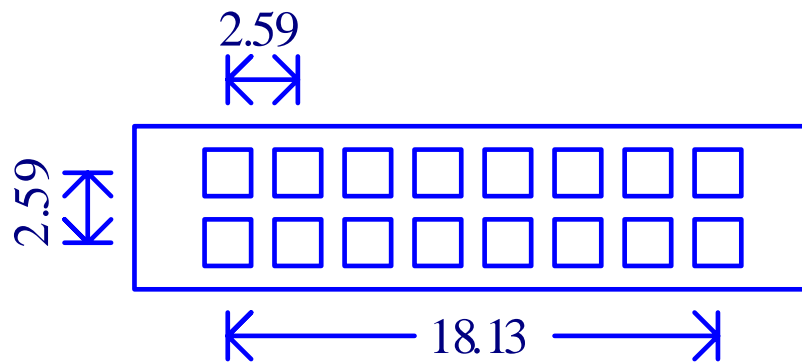
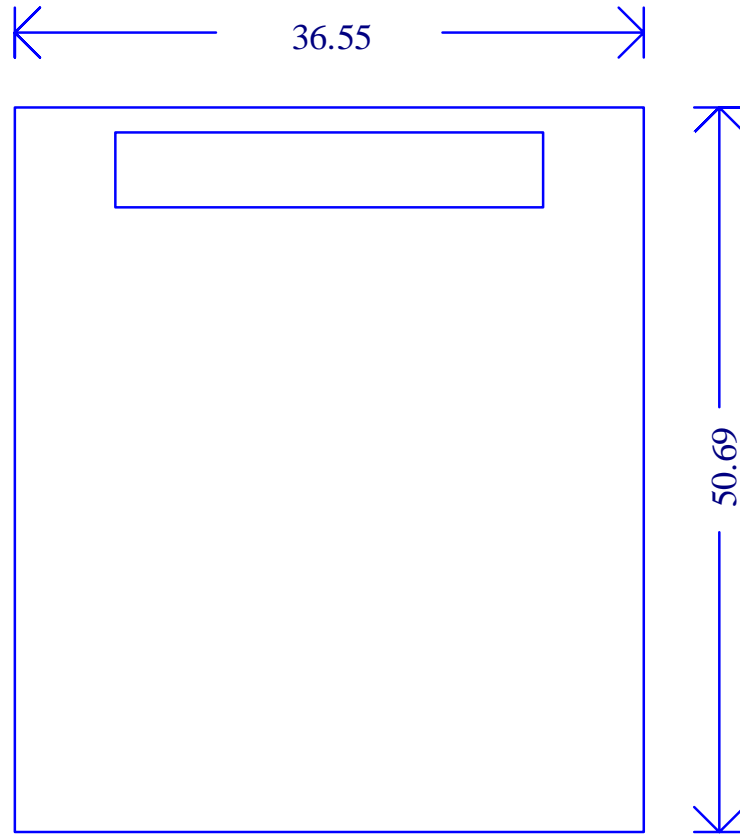

10.3、WTV020-SD-20S MODULE

Unit: mm

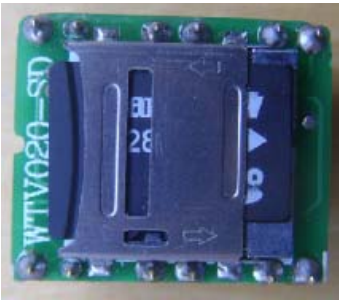

11.SUPPLY INFORMATION

In order to save customers production cost ,and good looking, we are not only sell modules, also we can sell the chips on the module.customers can make it on their circuit board.

ITEM	PICTURE
WTV020-SD-16P	
WTV020-SD-20S	
WTV020SD-20S (above two modules use this chip)	

GUANGZHOU WAYTRONIC ELECTRONIC CO., LTD.

Tel: 86-20-85638557, 5638319, 85638660

Fax: 86-20-85638637